

-Table of Contents-

**Appendix A KX-21 Parts List**

	Page
KX-21 Front View.....	A-1-02
KX-21 Right Side View.....	A-1-04
KX-21 Left Side View.....	A-1-06
Valve Unit A & B.....	A-1-08
Regulator Unit.....	A-1-10
Detector Block.....	A-1-11
Printer Unit.....	A-1-12
Pneumatic Unit KX-21.....	A-1-13
Pneumatic Unit KX-21 (W/PSL-21).....	A-1-14
PCB No. 4087 Assembly.....	A-1-15
KX-21 Recommended Parts.....	A-2-01
Alphabetical Order.....	A-3-01
Code No. Order.....	A-4-01

KX-21 Front View

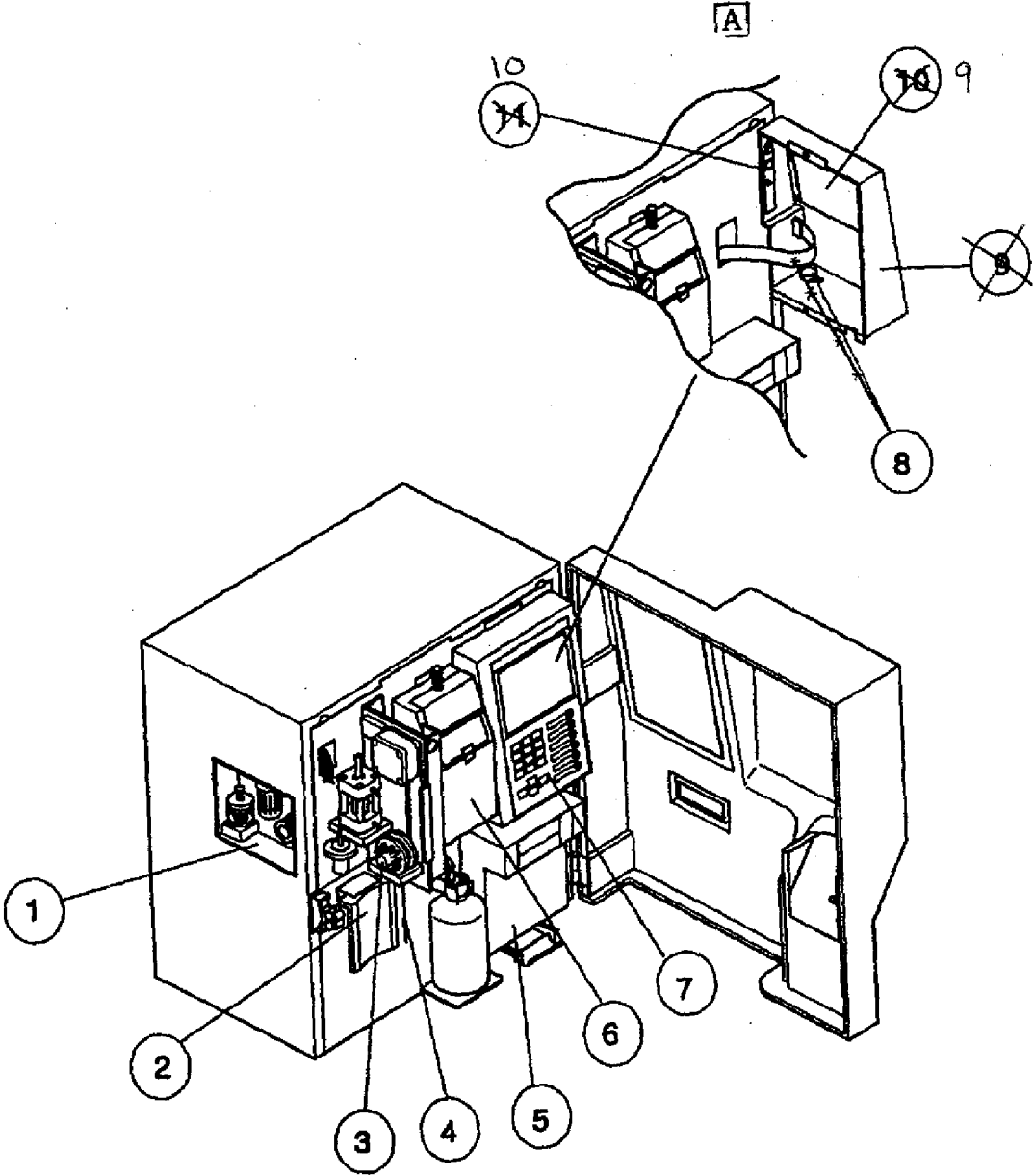

KX-21 Front View

Code No.	Drawing No.	Description	Q'ty per Unit
973-2891-3	1	REGULATOR UNIT KX-21	UNSALABLE
923-5151-0	2	SWITCH NO.83 ASSY	1
973-2761-6	3	SRV UNIT KX-21	UNSALABLE
441-1634-7	4	PIPETTE NO.57	1
973-3001-8	5*	PRINTER UNIT KX-21	UNSALABLE
973-2821-2	6	DETECTOR BLOCK KX-21	UNSALABLE
<b>A</b> <del>263-9534-9</del>	<del>7</del>	<del>PANEL KEYBOARD KX-21</del>	<del>1</del>
<del>953-1211-8</del>	<del>8</del>	<del>VOLUME WITH WIRING NO.14</del>	<del>1</del> <b>A</b>
<b>A</b> <del>973-2991-9</del>	<del>9</del>	<del>OPERATION PANEL KX-21</del>	<del>1</del>
<del>228-3755-1</del>	<del>10</del>	<del>LCD UNIT LSUBL 6131 A</del>	<del>1</del> <b>A</b>
<b>A</b> <del>228-9154-6</del>	<del>11</del>	<del>DC-AC INVERTER CXA-L0612-VJL</del>	<del>1</del>
973-2991-9	7-10	OPERATION PANEL KX-21	1 <b>A</b>
<b>A</b> 263-9534-9	7	PANEL KEYBOARD KX-21	1
953-1211-8	8	VOLUME WITH WIRING NO.14	1 <b>A</b>
<b>A</b> 228-3755-1	9	LCD UNIT LSUBL 6131 A	1
228-9154-6	10	DC-AC INVERTER CXA-L0612-VJL	1 <b>A</b>
322-3574-1	11	COVER UPPER/SIDE KX-21	1 <b>B</b>
322-3573-7	12	FRONT COVER KX-21	1 <b>B</b>

\*: FOR CHINESE MARKET ONLY.

# KX-21 Right Side View

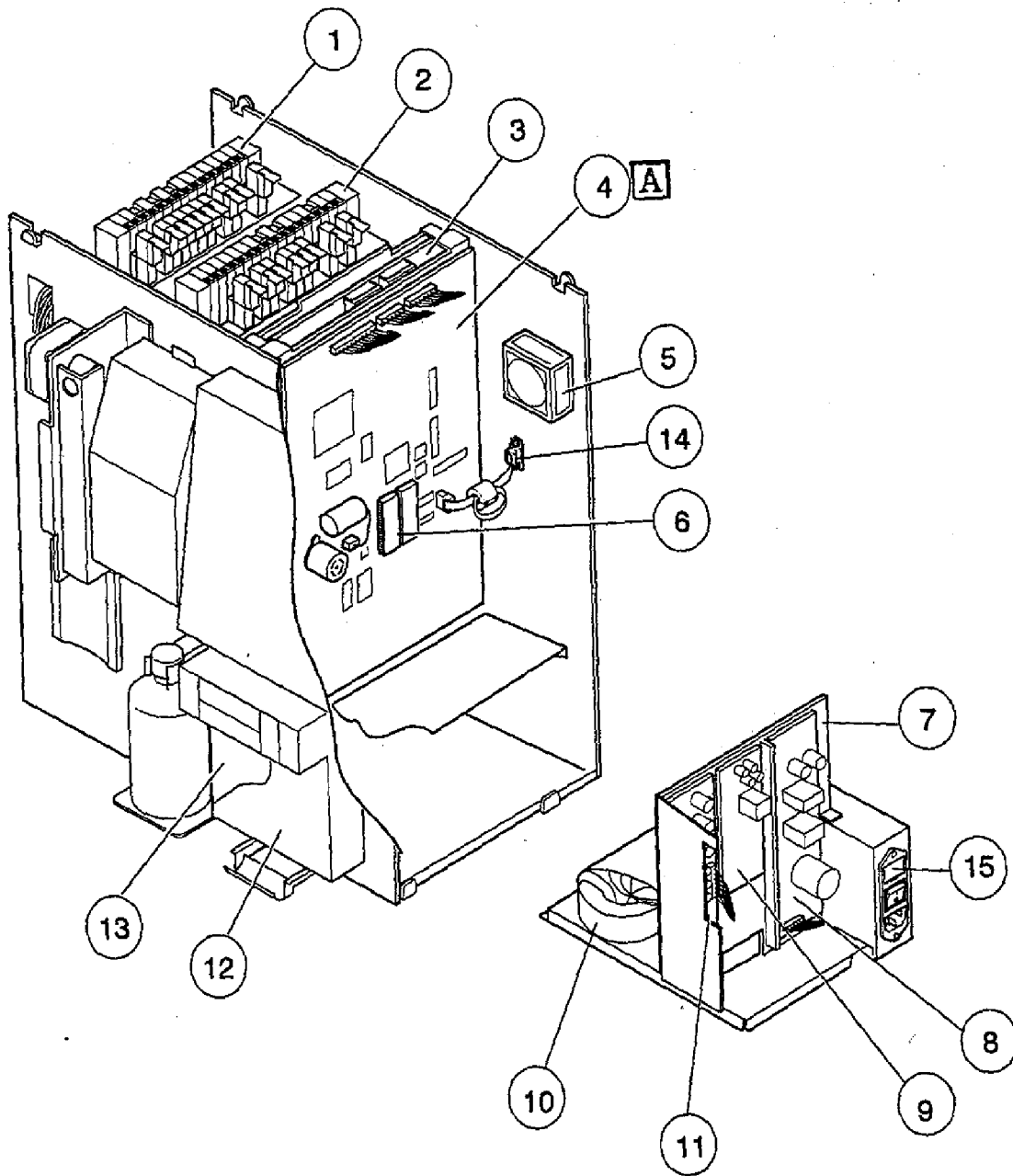

### KX-21 Right Side View

Code No.	Drawing No.	Description	Q'ty per Unit
973-2931-5	1	VALVE UNIT-B	UNALABLE
973-2901-3	2	VALVE UNIT-A	UNALABLE
261-0701-0	3	PCB NO.2135	1
<b>A</b> 261-0800-1	4	PCB NO.6363	1
933-4591-2	5	FAN ASSEMBLY NO.19	1
973-3311-1	6	ROM 1KX2F ASSY	1
973-3011-5	7¥	FOR JAPANESE MARKET	UNALABLE
973-3012-9	7\$	POWER SUPPLY UNIT (C2/117V)	UNALABLE
973-3013-2	7#	POWER SUPPLY UNIT (C3/220V)	UNALABLE
973-3014-6	7*	POWER SUPPLY UNIT (C4/240V)	UNALABLE
289-9642-9	8	SWITCHING REGULATOR VS50B-12	1
289-9641-5	9	SWITCHING REGULATOR VS15B-5	1
241-2108-9	10\$¥	TRANSFORMER POWER PT-094	1
241-2109-2	10#*	TRANSFORMER POWER PT-095	1
261-0758-1	11	PCB NO.4087	1
322-3577-1	12	PRINTER UNIT COVER KX-21	1
662-0168-8	13	PCB NO.6350 WITH ROM	1
973-4531-1	14	OUTPUT UNIT NO. 1 KX-21	1
266-5109-1	15\$¥	FUSE 250V3.15A ST4-3.15A-N1	10
266-5292-6	15#*	FUSE 250V2A NO.19195 (EUROPE)	10

¥: FOR 100 VAC.  
 \$: FOR 117 VAC.  
 #: FOR 220 VAC.  
 \*: FOR 240 VAC.

SYM	ECR NO.	SERIAL NO.
<b>A</b>	398G031	A1867-

# KX-21 Left Side View

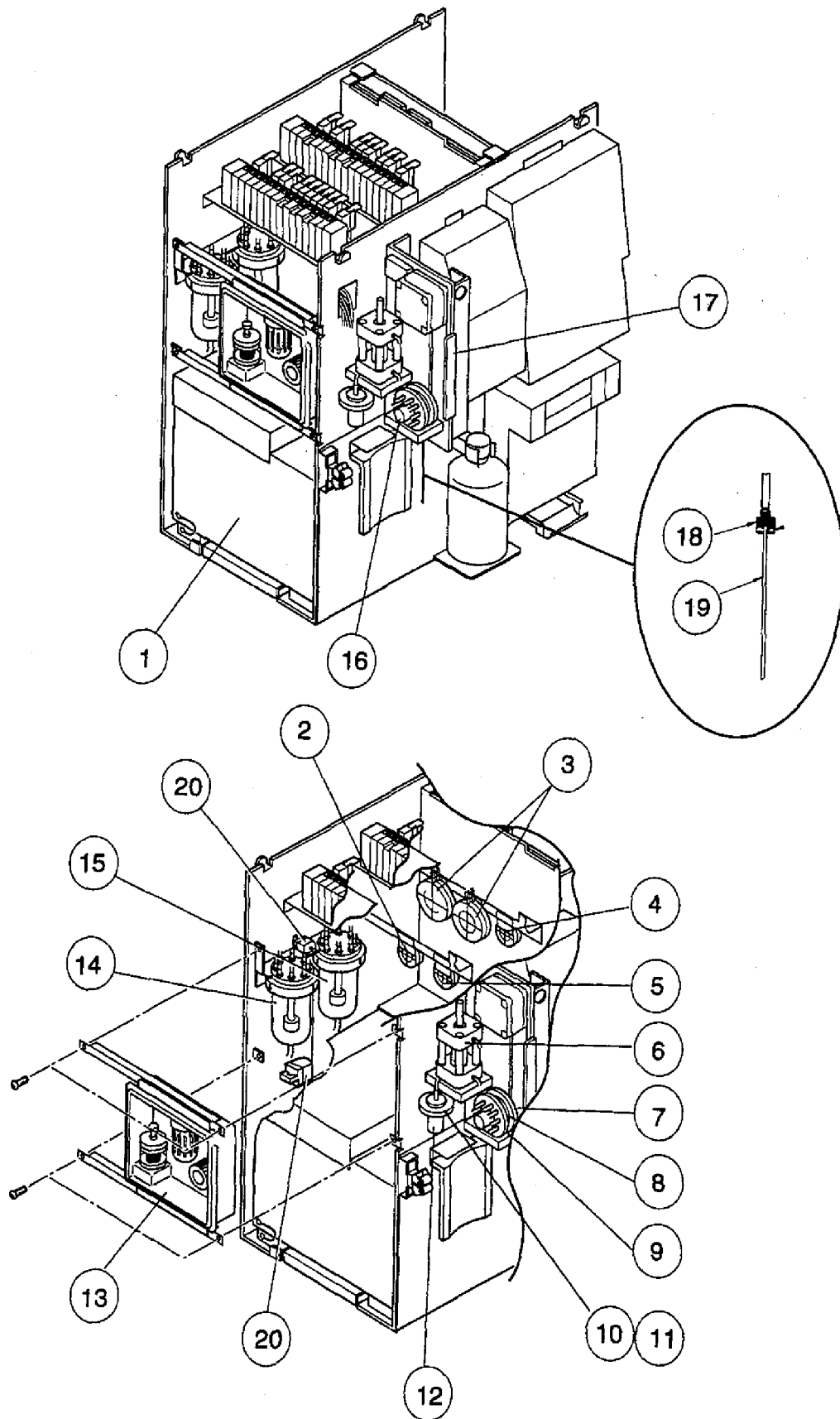

KX-21 Left Side View

Code No.	Drawing No.	Description	Q'ty per Unit
973-2982-5	1	PNEUMATIC UNIT KX-21 (W/PSL-21	1
973-2941-2	2	DIAPHRAGM PUMP ASSY NO.51 (0.2)	1
973-2911-1	3	DIAPHRAGM PUMP ASSY NO.49 (2.0)	1
973-2921-8	4	DIAPHRAGM PUMP ASSY NO.50 (1.0)	1
973-2951-0	5	DIAPHRAGM PUMP ASSY NO.52 (0.05)	1
443-3169-1	6	AIR CYLINDER T-2437	1
973-2811-5	7	SRV FIXED VALVE NO.28-R ASSY	1
973-2791-8	8	SAMPLE ROTOR VALVE NO.17 ASSY	1
973-2801-8	9	SRV FIXED VALVE NO.28-L ASSY	1
363-5382-6	10	FIXING MATERIAL NO.639	1
363-5022-6	11	FIXING MATERIAL NO. 22	1
443-2537-1	12	GLASS CHAMBER GC-37	1
973-2891-3	13	REGULATOR UNIT KX-21	UNALABLE
973-2971-4	14	WASTE CHAMBER NO.39 ASSY	1
913-0927-0	15	DILUENT CHAMBER NO.10 ASSY (C7)	1
973-2781-1	16	SAMPLE ROTOR FIXTURE NO. 6	1
973-2771-3	17	DRIVE MECHANISM NO.58 ASSY	1
442-3460-8	18	FITTING NO. 9-A	1
441-1634-7	19	PIPETTE NO.57	1
443-1290-9	20	PINCH VALVE K-1 ASSY	1

# Valve Unit A & B

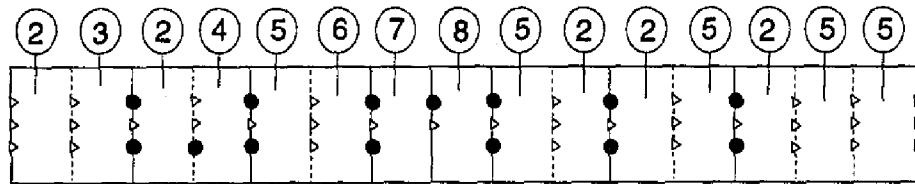
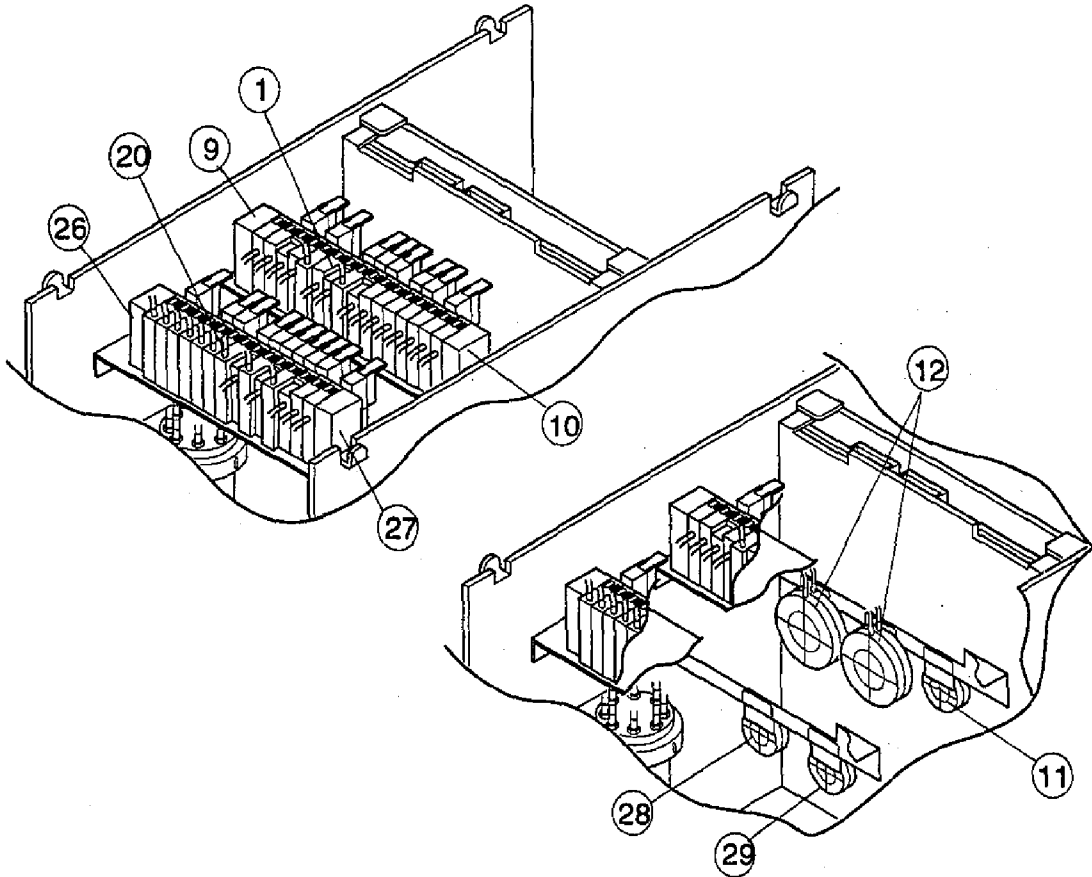

Valve Unit A-1

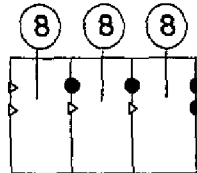

Valve Unit A-2

● O-Ring + Plug  
▷ O-Ring

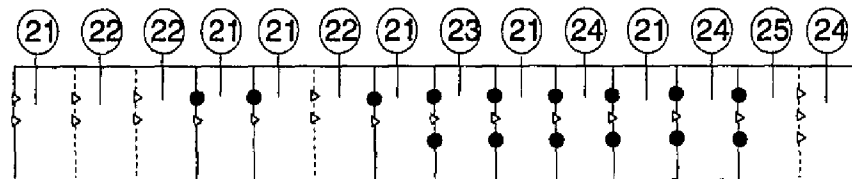

Valve Unit B



Valve Unit A & B

Code No.	Drawing No.	Description	Q'ty per Unit
973-2901-3	1	VALVE UNIT-A	UNSATABLE
443-9657-6	2	AIR VALVE WTKV023-4E1-PLL-DC12	1
443-9650-1	3	AIR VALVE WTKV014	1
443-8655-5	4	AIR VALVE WTKV012	1
443-8657-2	5	AIR VALVE WTKV013	1
443-9658-0	6	AIR VALVE WTKV024-4E1-PLL-DC12	1
443-8656-9	7	AIR VALVE WTKV012-E1-PLL-DC12	1
443-8660-4	8	AIR VALVE WTKV011-E1-PLL-DC12	1
443-8663-5	9	END PLATE WTKV010-L	1
443-8662-1	10	END PLATE WTKV010-R	1
<b>A</b> <del>973-2921-8</del>	<del>11</del>	<del>DIAPHRAGM PUMP ASSY NO.50 (1.0)</del>	<del>1</del>
<b>A</b> <del>973-2911-1</del>	<del>12</del>	<del>DIAPHRAGM PUMP ASSY NO.49 (2.0)</del>	<del>1</del>
973-2931-5	20	VALVE UNIT-B	UNSATABLE
443-8656-9	21	AIR VALVE WTKV012-E1-PLL-DC12	1
443-8655-5	22	AIR VALVE WTKV012	1
443-9658-0	23	AIR VALVE WTKV024-4E1-PLL-DC12	1
443-9657-6	24	AIR VALVE WTKV023-4E1-PLL-DC12	1
443-9650-1	25	AIR VALVE WTKV014	1
443-8663-5	26	ENDPLATE WTKV010-L	1
443-8662-1	27	END PLATE WTKV010-R	1
973-2941-2	28	DIAPHRAGM PUMP ASSY NO.51 (0.2)	1
973-2951-0	29	DIAPHRAGM PUMP ASSY NO.51 (0.05)	1
		52 <b>B</b>	
<b>A</b> 873-0647-7	11	DIAPHRAGM PUMP ASSY NO.5 (1.0)	1
<b>A</b> 923-5541-4	12	DIAPHRAGM PUMP ASSY NO.34 (2.0)	1

**A** 398J015

A1097, A1121, A1236 thru A1239, A1294, A1295, A1306, A1307, A1356 thru A1365, A1455, A1463, A1476, A1477, A1479 thru A1485, A1636 thru A1655, A1713 thru A1790, A1803, A1806 thru A1808, A1810 thru A1812, A1827, A1852 thru A1915, A1917, A1918, A1920 thru A1949, A1951 thru A2050, A2094, A2096, A2101, A2111, A2147 thru A2194, A2151 thru A2161, A2181, A2184, A2198 and thereafter

KX-21 S/M

A-1-9

SYM	ECR NO.	SERIAL NO.
	TB 99003	_____

January 1999

Revised by ECR398J015

# Regulator Unit

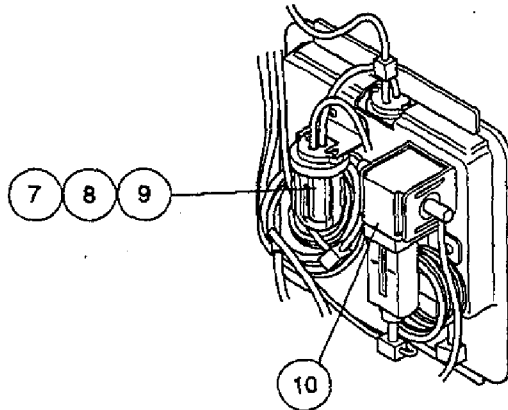
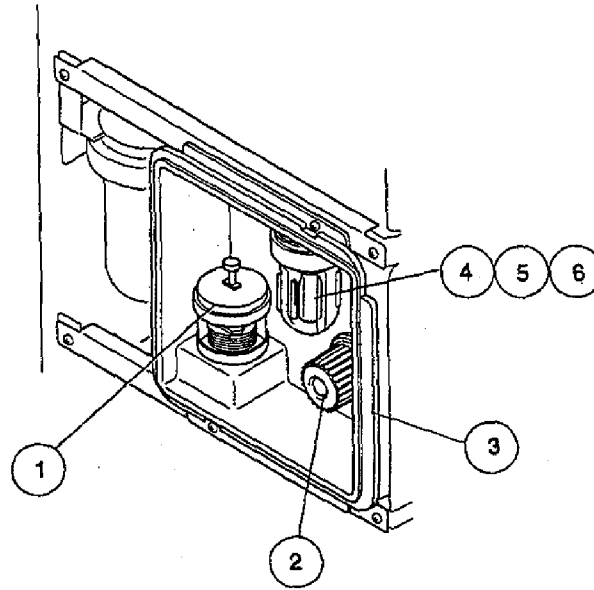

SYM	ECR NO.	SERIAL NO.
A	398E030	A1851-

Code No.	Drawing No.	Description	Q'ty per Unit
367-8202-2	1	BELLOWS NO.2 WITH METAL	1
<del>443-1971-6</del>	<del>2</del>	<del>RELIEF VALVE-247L-1V-1/8Z171</del>	<del>1</del> <span style="border: 1px solid black; padding: 2px;">A</span>
323-3713-1	3	REGULATOR UNIT CHASSIS	1
893-5012-3	4-6	TRAP CHAMBER NO. 9 ASY (C2/K45)	UNALABLE
365-1617-0	4	SUPPORT NO.104	1
443-1411-5	5	FLOAT NO. 1	1
443-0836-6	6	CHAMBER NO.17	1
933-3431-0	7-9	PU PROTECTION FILTER NO.1 ASSY	UNALABLE
365-1617-0	7	SUPPORT NO.104	1
443-1362-0	8	FILTER NO. 9	1
443-0836-6	9	CHAMBER NO.17	1
443-2455-2	10	AIR FILTER F1000-6-B	1
443-1972-0	2	RELIEF VALVE 247L4-1VZH	1 <span style="border: 1px solid black; padding: 2px;">A</span>

# Detector Block

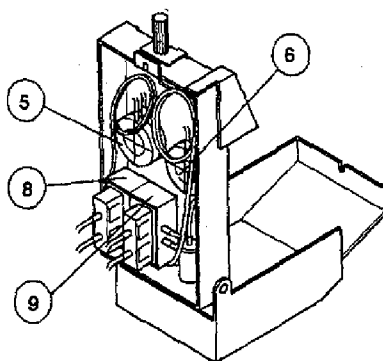
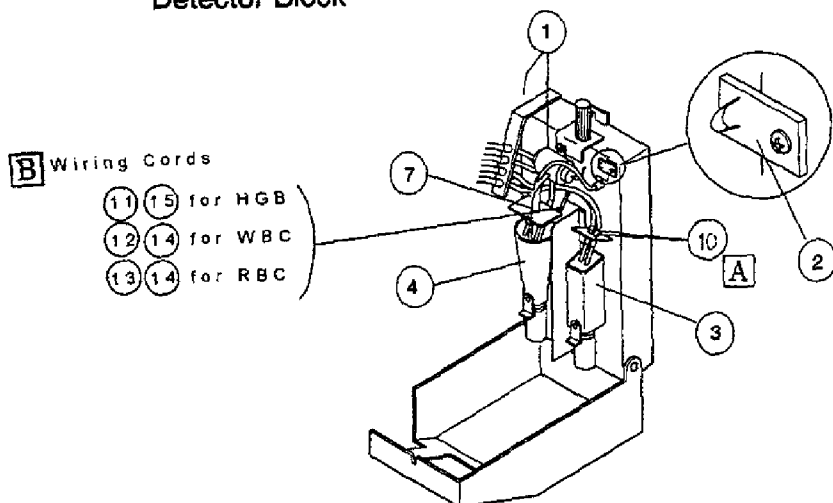

Code No.	Drawing No.	Description	Qty per Unit
973-2841-7	1	HGB UNIT KX-21	1
973-2881-6	2	THERMISTOR ASSY NO.37	1
903-2291-2	3	TRANSDUCER NO. 3 ASSY (RBC)	1
973-2831-0	4	TRANSDUCER NO.8 ASSY	1
973-2871-9	5	DIAPHRAGM PUMP ASSY NO.48 (0.25)	1
963-3661-9	6	DIAPHRAGM PUMP ASSY NO.45 (0.5)	1
442-8503-9	7	TUBING NO.103	1
973-2851-4	8	MASTER VALVE 3MV14-AF ASSY	1
973-2861-1	9	MASTER VALVE 3MV17-C ASSY	1
442-3575-9	10	NIPPLE NO. 73	10 <b>A</b>
<b>B</b> 973-3141-2	11	WIRING CORD NO.2365	1
<b>B</b> 973-3131-5	12	WIRING CORD NO.2364	1
<b>B</b> 973-3121-8	13	WIRING CORD NO.2363	1
266-7179-9	14	FERRITE CLAMP TFC-23-11-14	1
<b>B</b> 266-7126-1	15	FERRITE CLAMP SFC-5	1

KX-21 S/M

A-1-11

**A** Revised March 1999  
By TB 99003

**B** TB 99045

# Printer Unit

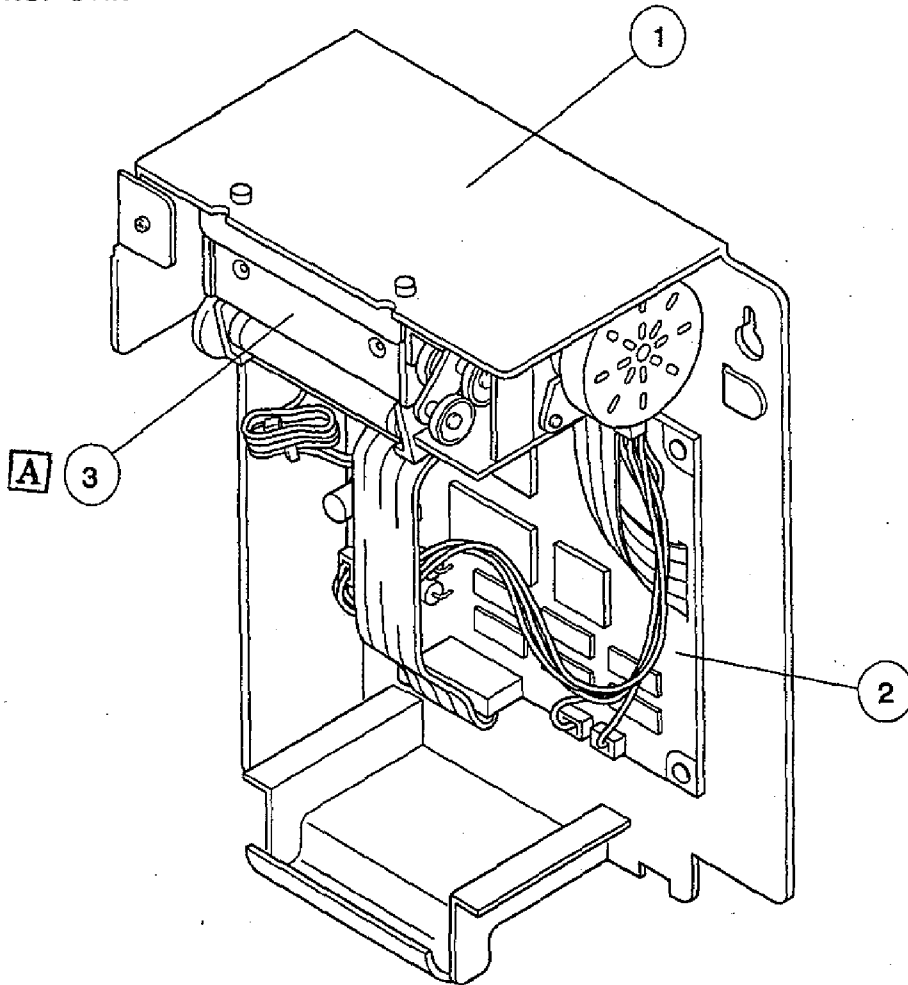

Code No.	Drawing No.	Description	Q'ty per Unit
323-3719-3	1	PRINTER UNIT CHASSIS	UNALABLE
662-0168-8	2	PCB NO.6350 WITH ROM	1
<del>A 281-7226-1</del>	<del>3</del>	<del>PRINTER FTP-421MCL001</del>	<del>1</del>
A 281-7226-1 B	3	PRINTER FTP-421MCL571	1

SYM	ECR NO.	SERIAL NO.
A	398C005	A1086-

# Pneumatic Unit KX-21 (with PSL-21Z)

SYM	ECR NO.	SERIAL NO.
A	398G045	A2051-
B	399B017	

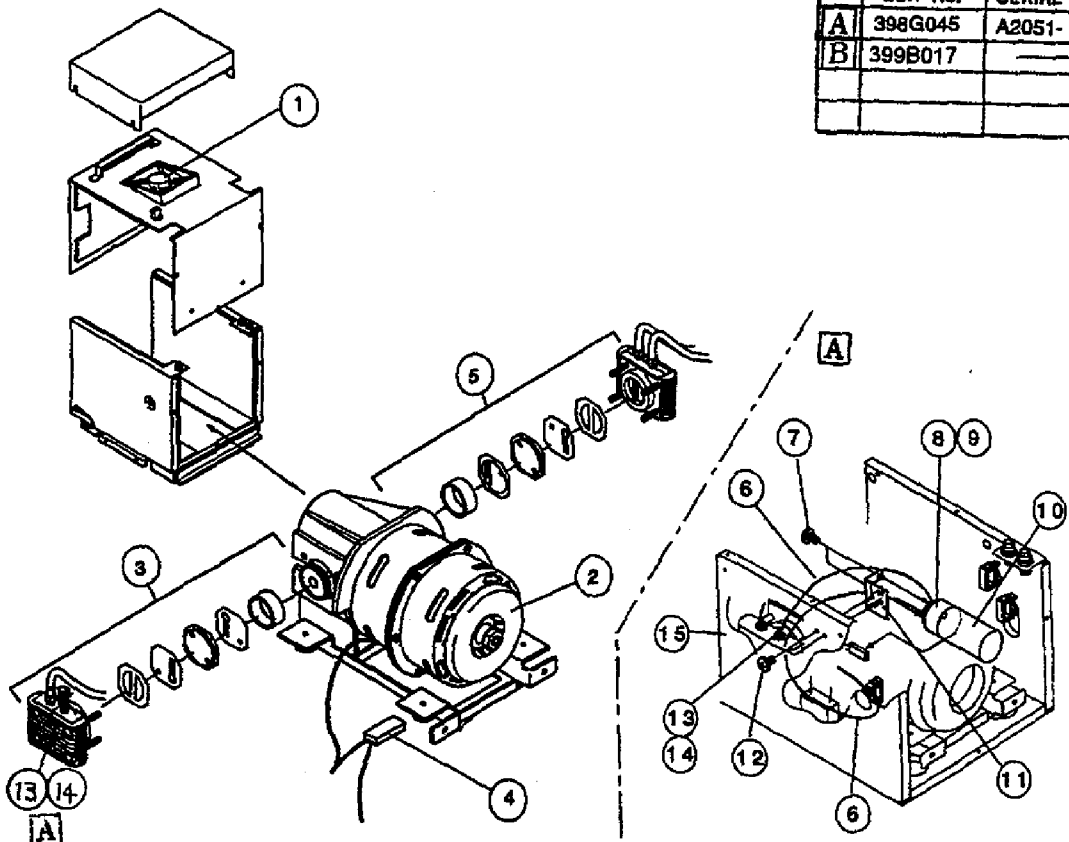

Code No.	Drawing No.	Description	Qty per Unit
281-0120-9	1	FAN FBA09A12HAZ	1
443-6954-1	2	PISTON PUMP PSL-21Z	1
443-6880-2	3	VACUUM PARTS SET FOR 21Z-PSV	1
266-8577-7	4	THERMAL PROTECTOR T70AR1U1N	1
443-6881-6	5	PRESSURE PARTS SET FOR 21Z-PSP	1
442-5338-7	6	TUBE POLYURETHANE 4MMIDX6MMOD	10 M
348-3812-1	7	SCREW BINDING M3X6 (SUS)	100
442-3029-0	8	ADAPTOR NO.29	1
346-3614-2	9	O-RING IN-20	10
443-0872-1	10	CHAMBER NO.48	1
366-0780-4	11	CHAMBER MOUNTING PLATE NO.60	1
348-3911-2	12	SCREW BINDING M3X4 (SUS)	100
442-4145-9	13	FITTING BN-6 X 4 X PT 1/8 BSN	5
365-6401-8	14	SLEEVE METAL MS-06	10
368-5760-2	15	ANTI-NOISE SPONGE NO.49-J	1
981-0771-7	PM	KX-21 PNEUMATIC REPLACE KIT	1

## Pneumatic Unit KX-21 (with PSL-21)

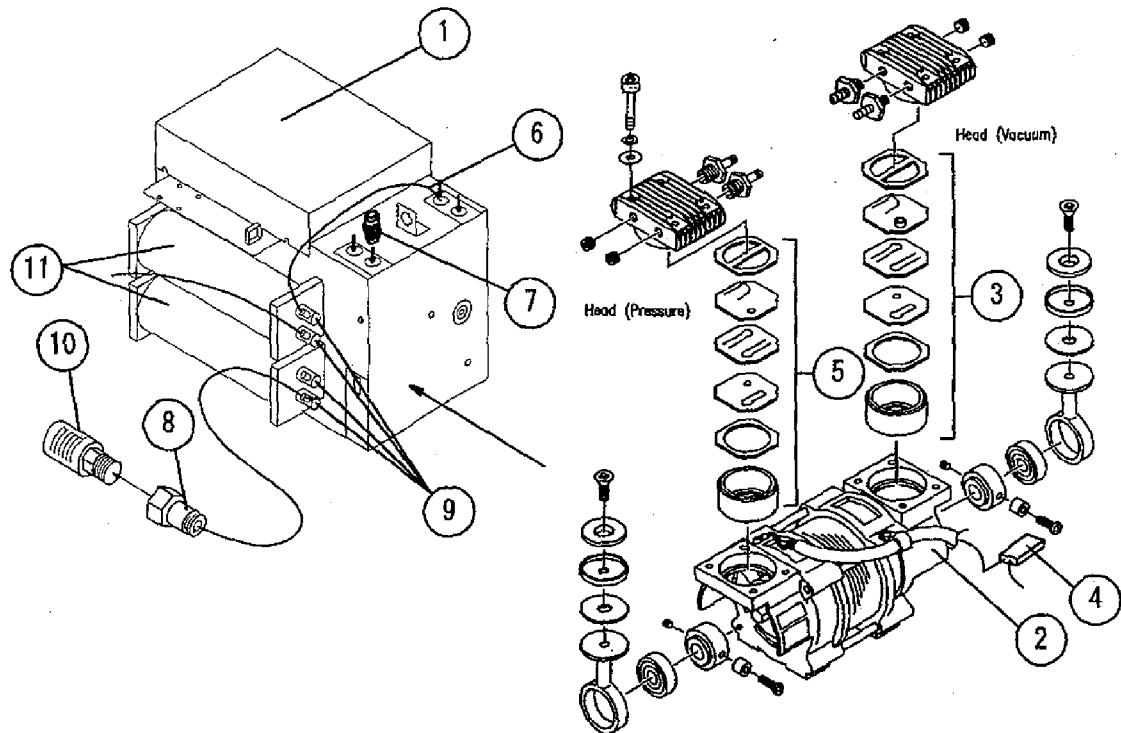

Code No.	Drawing No.	Description	Q'ty per Unit
281-0120-9	1	FAN FBA09A12HAZ	1
443-6953-7	2	PISTON PUMP PSL-21	1
443-6865-6	3	VACUUM PARTS SET FOR PSL-21	1
266-8577-7	4	THERMAL PROTECTOR T70AR1U1N	1
443-6866-0	5	PRESSURE PARTS SET FOR PSL-21	1
442-5338-7	6	TUBE POLYURETHANE 4MMIDX6MMOD	10 M
442-4603-0	7	FITTING UK 6M	1
442-4575-2	8	FITTING TSM6-02	5
442-4149-3	9	FITTING BL-6 X 4 X PT 1/8 BSN	5
449-1508-2	10	SILENCER SLW-8A (SL-1/4)	1
443-0702-5	11	TANK NO. 29	1

PCB No. 4087 Assembly

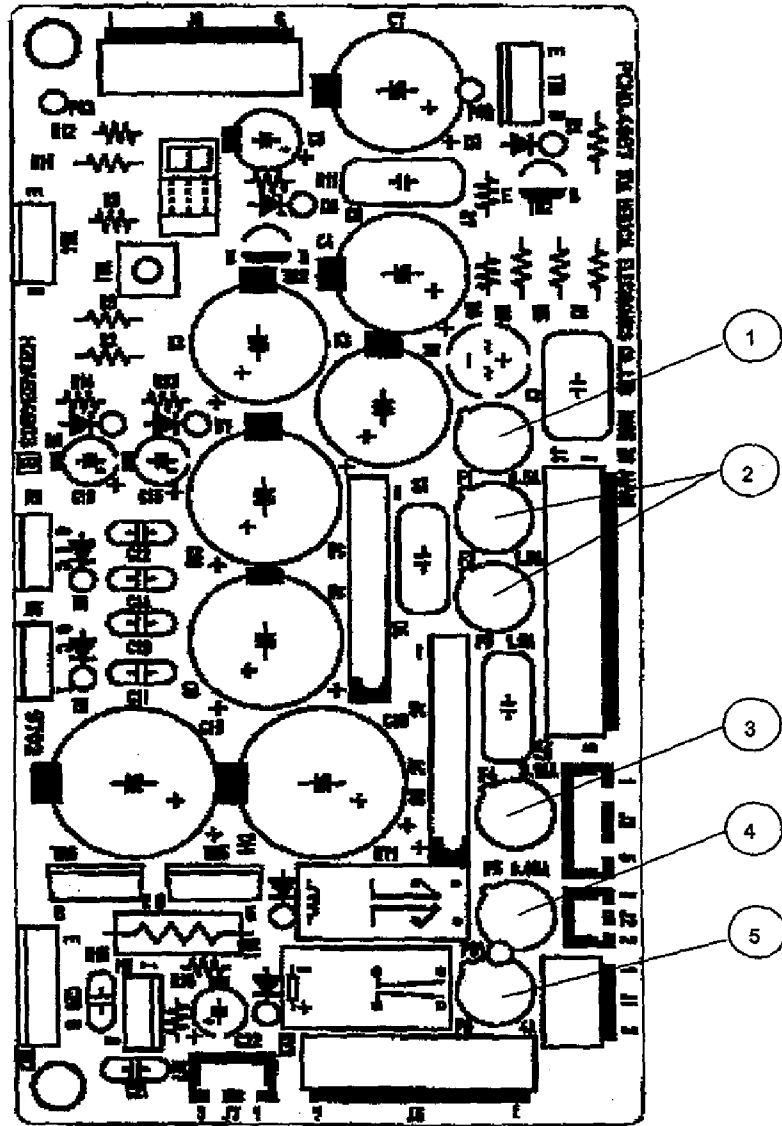

Code No.	Drawing No.	Description	Q'ty per Unit
266-5377-5	1	FUSE 0.5A K19374	10
266-5433-7	2	FUSE 1.6A K19374	10
266-5434-1	3	FUSE 3.15A K19374	10
266-5375-8	4	FUSE 0.05A K19374	10
266-5435-4	5	FUSE 4A K19374	10

KX-21 Recommend Parts

Code	Description	Unit Q'ty	Model
228-3755-1	LCD UNIT LSUBL 6131 A	1	KX-21
228-9154-6	DC-AC INVERTER CXA-L0612-VJL	1	KX-21
241-2108-9	TRANSFORMER POWER PT-094	1	KX-21
261-0701-0	PCB NO.2135	1	KX-21
261-0758-1	PCB NO.4087	1	KX-21
261-0800-1	PCB NO.6363	1	KX-21
263-9534-9	PANEL KEYBOARD KX-21	1	KX-21
266-8577-7	THERMAL PROTECTOR T70AR1U1N	1	K-4500
289-9641-5	SWITCHING REGULATOR VS15B-5	1	KX-21
289-9642-9	SWITCHING REGULATOR VS50B-12	1	KX-21
363-5382-6	FIXING MATERIAL NO.639	1	K-800
441-1634-7	PIPETTE NO.57	1	KX-21
442-3460-8	FITTING NO. 9-A	1	K-4500
442-8503-9	TUBING NO.103	1	KX-21
443-1972-0	RELIEAF VALVE 247L4-1VZH	1	KX-21
443-2455-2	AIR FILTER F1000-6-B	1	KX-21
443-2537-1	GLASS CHAMBER GC-37	1	K-1000
443-6865-6	VACUUM PARTS SET FOR PSL-21	1	K-4500
443-6866-0	PRESSURE PARTS SET FOR PSL-21	1	K-4500
662-0168-8	PCB NO.6350 WITH ROM	1	K-4500/F82
873-0647-7	DIAPHRAGM PUMP NO.5 ASSY KX-21	1	KX-21
923-5541-4	DIAPHRAGM PUMP NO.34 ASSY	1	SE-9000
933-4591-2	FAN ASSEMBLY NO.19	1	K-4500
963-3661-9	DIAPHRAGM PUMP ASSY NO.45(0.5)	1	KX-21
973-2771-3	DRIVE MECHANISM NO.58(C1/KX21)	1	KX-21
973-2781-1	SAMPLE ROTOR FIXTURE NO. 6	1	KX-21
973-2791-8	SAMPLE ROTOR VALVE NO.17 ASSY	1	KX-21
973-2801-8	SRV FIXED VALVE NO.28-L ASSY	1	KX-21
973-2811-5	SRV FIXED VALVE NO.28-R ASSY	1	KX-21
973-2831-0	TRANSDUCER NO. 8 ASSY	1	KX-21
973-2871-9	DIAPHRAGM PUMP ASSY NO.48(0.25)	1	KX-21
973-2881-6	THERMISTOR ASSY NO.37	1	KX-21
973-2941-2	DIAPHRAGM PUMP ASSY NO.51(0.2)	1	KX-21
973-2951-0	DIAPHRAGM PUMP ASSY NO.52(0.05)	1	KX-21



KX-21 Parts List Alphabetical Order

Description	Code No.	Unit/Qty	Page	Item No.
AIR CYLINDER T-2437	443-3169-1	1	A-1-6	6
AIR FILTER F1000-6-B	443-2455-2	1	A-1-10	10
AIR VALVE WTKV011-E1-PLL-DC12	443-8660-4	1	A-1-8	8
AIR VALVE WTKV012	443-8655-5	1	A-1-8	4
			A-1-8	22
AIR VALVE WTKV012-E1-PLL-DC12	443-8656-9	1	A-1-8	7
			A-1-8	21
AIR VALVE WTKV013	443-8657-2	1	A-1-8	5
AIR VALVE WTKV014	443-9650-1	1	A-1-8	3
			A-1-8	25
AIR VALVE WTKV023-4E1-PLL-DC12	443-9657-6	1	A-1-8	2
			A-1-8	24
AIR VALVE WTKV024-4E1-PLL-DC12	443-9658-0	1	A-1-8	6
			A-1-8	23
BELLOWS NO.2 WITH METAL	367-8202-2	1	A-1-10	1
CHAMBER NO.17	443-0836-6	1	A-1-10	6
			A-1-10	9
DC-AC INVERTER CXA-L0812-VJL	228-9154-6	1	A-1-2	11
DETECTOR BLOCK KX-21	973-2821-2	UNSALEABLE	A-1-2	6
DIAPHRAGM PUMP ASSY NO.45 (0.5)	963-3661-9	1	A-1-11	6
DIAPHRAGM PUMP ASSY NO.48 (0.25)	973-2871-9	1	A-1-11	5
DIAPHRAGM PUMP ASSY NO.49 (2.0)	973-2911-1	1	A-1-6	3
			A-1-8	12
DIAPHRAGM PUMP ASSY NO.50 (1.0)	973-2921-8	1	A-1-6	4
DIAPHRAGM PUMP ASSY NO.50 (1.0)	973-2921-8	1	A-1-8	11
DIAPHRAGM PUMP ASSY NO.51 (0.2)	973-2941-2	1	A-1-6	2
DIAPHRAGM PUMP ASSY NO.52 (0.05)	973-2951-0	1	A-1-6	5
DILUENT CHAMBER NO.10 ASSY (C7)	913-0927-0	1	A-1-6	15
DRIVE MECHANISM NO.58 ASSY	973-2771-3	1	A-1-6	17
END PLATE WTKV010-L	443-8663-5	1	A-1-8	9
END PLATE WTKV010-R	443-8662-1	1	A-1-8	10
			A-1-8	27
ENDPLATE WTKV010-L	443-8663-5	1	A-1-8	26
FAN ASSEMBLY NO.19	933-4591-2	1	A-1-4	5
FAN FBA09A12HAZ	281-0120-9	1	A-1-13	1
FILTER NO. 9	443-1362-0	1	A-1-10	8
FITTING NO. 9-A	442-3460-8	1	A-1-6	18
FIXING MATERIAL NO. 22	363-5022-6	1	A-1-6	11
FIXING MATERIAL NO.639	363-5382-6	1	A-1-6	10
FLOAT NO. 1	443-1411-5	1	A-1-10	5
FUSE 0.05A K19374	266-5375-8	10	A-1-14	4
FUSE 0.5A K19374	266-5377-5	10	A-1-14	1
FUSE 1.6A K19374	266-5433-7	10	A-1-14	2
FUSE 250V2A NO.19195 (EUROPE)	266-5292-6	10	A-1-4	15#*
FUSE 250V3.15A ST4-3.15A-N1	266-5109-1	10	A-1-4	15\$
FUSE 3.15A K19374	266-5434-1	10	A-1-14	3
FUSE 4A K19374	266-5435-4	10	A-1-14	5
GLASS CHAMBER GC-37	443-2537-1	1	A-1-6	12
HGB UNIT KX-21	973-2841-7	1	A-1-11	1
KX-21 PNEUMATIC REPLACE KIT	981-0771-7	1	A-1-13	PM
LCD UNIT LSUBL 6131 A	228-3755-1	1	A-1-2	10
MASTER VALVE 3MV14-AF ASSY	973-2851-4	1	A-1-11	8
MASTER VALVE 3MV17-C ASSY	973-2861-1	1	A-1-11	9

KX-21 Parts List Alphabetical Order

Description	Code No.	Unit/Q'ty	Page	Item No.
OPERATION PANEL KX-21	973-2991-9	1	A-1-2	9
OUTPUT UNIT NO. 1 KX-21	973-4531-1	1	A-1-4	14
PANEL KEYBOARD KX-21	263-9534-9	1	A-1-2	7
PCB NO.2135	261-0701-0	1	A-1-4	3
PCB NO.4087	261-0758-1	1	A-1-4	11
PCB NO.6350 WITH ROM	662-0168-8	1	A-1-4	13
			A-1-12	2
PCB NO.6363	261-0800-1	1	A-1-4	4
PINCH VALVE K-1 ASSY	443-1290-9	1	A-1-6	20
PIPETTE NO.57	441-1634-7	1	A-1-2	4
			A-1-6	19
PISTON PUMP PSL-21Z	443-6954-1	1	A-1-13	2
PNEUMATIC UNIT KX-21	973-2981-1	UNSATABLE	A-1-6	1
PNEUMATIC UNIT KX-21 (W/PSL-21	973-2982-5	1	A-1-6	1
POWER SUPPLY UNIT (C2/117V)	973-3012-9	UNSATABLE	A-1-4	7\$
POWER SUPPLY UNIT (C3/220V)	973-3013-2	UNSATABLE	A-1-4	7#
POWER SUPPLY UNIT (C4/240V)	973-3014-6	UNSATABLE	A-1-4	7*
PRESSURE PARTS SET FOR 21Z-PSP	443-6881-6	1	A-1-13	5
PRINTER FTP-421MCL571	281-7226-1	1	A-1-12	3
PRINTER UNIT CHASSIS	323-3719-3	UNSATABLE	A-1-12	1
PRINTER UNIT COVER KX-21	322-3577-1	1	A-1-4	12
PRINTER UNIT KX-21	973-3001-8	UNSATABLE	A-1-2	5*
PU PROTECTION FILTER NO.1 ASSY	933-3431-0	UNSATABLE	A-1-10	7-9
REGULATOR UNIT CHASSIS	323-3713-1	1	A-1-10	3
REGULATOR UNIT KX-21	973-2891-3	UNSATABLE	A-1-2	1
			A-1-6	13
RELIEF VALVE 247L-1V-1/8Z171	443-1971-6	1	A-1-10	2
ROM 1KX2F ASSY	973-3311-1	1	A-1-4	6
SAMPLE ROTOR FIXTURE NO. 6	973-2781-1	1	A-1-6	16
SAMPLE ROTOR VALVE NO.17 ASSY	973-2791-8	1	A-1-6	8
SRV FIXED VALVE NO.28-L ASSY	973-2801-8	1	A-1-6	9
SRV FIXED VALVE NO.28-R ASSY	973-2811-5	1	A-1-6	7
SRV UNIT KX-21	973-2761-6	UNSATABLE	A-1-2	3
SUPPORT NO.104	365-1617-0	1	A-1-10	4
			A-1-10	7
SWITCH NO.83 ASSY	923-5151-0	1	A-1-2	2
SWITCHING REGULATOR VS15B-5	289-9641-5	1	A-1-4	9
SWITCHING REGULATOR VS50B-12	289-9642-9	1	A-1-4	8
THERMAL PROTECTOR T70AR1U1N	266-8577-7	1	A-1-13	4
THERMISTOR ASSY NO.37	973-2881-6	1	A-1-11	2
TRANSDUCER NO. 3 ASSY (RBC)	903-2291-2	1	A-1-11	3
TRANSDUCER NO.8 ASSY	973-2831-0	1	A-1-11	4
TRANSFORMER POWER PT-094	241-2108-9	1	A-1-4	10\$
TRANSFORMER POWER PT-095	241-2109-2	1	A-1-4	10#*
TRAP CHAMBER NO. 9 ASY (C2/K45)	893-5012-3	UNSATABLE	A-1-10	4-6
TUBING NO.103	442-8503-9	1	A-1-11	7
VACUUM PARTS SET FOR 21Z-PSV	443-6880-2	1	A-1-13	3
VALVE UNIT-A	973-2901-3	UNSATABLE	A-1-4	2
			A-1-8	1
VALVE UNIT-B	973-2931-5	UNSATABLE	A-1-4	1
VALVE UNIT-B	973-2931-5	UNSATABLE	A-1-8	20
VOLUME WITH WIRING NO.14	953-1211-8	1	A-1-2	8
WASTE CHAMBER NO.39 ASSY	973-2971-4	1	A-1-6	14

KX-21 Parts List Code No. Order

Code No.	Description	Unit/Q'ty	Page	Item No.
228-3755-1	LCD UNIT LSUBL 6131 A	1	A-1-2	10
228-9154-6	DC-AC INVERTER CXA-L0612-VJL	1	A-1-2	11
241-2108-9	TRANSFORMER POWER PT-094	1	A-1-4	10\$
241-2109-2	TRANSFORMER POWER PT-095	1	A-1-4	10#*
261-0701-0	PCB NO.2135	1	A-1-4	3
261-0758-1	PCB NO.4087	1	A-1-4	11
261-0800-1	PCB NO.6363	1	A-1-4	4
263-9534-9	PANEL KEYBOARD KX-21	1	A-1-2	7
266-5109-1	FUSE 250V3.15A ST4-3.15A-N1	10	A-1-4	15\$
266-5292-6	FUSE 250V2A NO.19195 (EUROPE)	10	A-1-4	15#*
266-5375-8	FUSE 0.05A K19374	10	A-1-14	4
266-5377-5	FUSE 0.5A K19374	10	A-1-14	1
266-5433-7	FUSE 1.6A K19374	10	A-1-14	2
266-5434-1	FUSE 3.15A K19374	10	A-1-14	3
266-5435-4	FUSE 4A K19374	10	A-1-14	5
266-8577-7	THERMAL PROTECTOR T70AR1U1N	1	A-1-13	4
281-0120-9	FAN FBA09A12HAZ	1	A-1-13	1
281-7226-1	PRINTER FTP-421MCL571	1	A-1-12	3
289-9641-5	SWITCHING REGULATOR VS15B-5	1	A-1-4	9
289-9642-9	SWITCHING REGULATOR VS50B-12	1	A-1-4	8
322-3577-1	PRINTER UNIT COVER KX-21	1	A-1-4	12
323-3713-1	REGULATOR UNIT CHASSIS	1	A-1-10	3
323-3719-3	PRINTER UNIT CHASSIS	UNSALEABLE	A-1-12	1
363-5022-6	FIXING MATERIAL NO. 22	1	A-1-6	11
			A-1-6	10
365-1617-0	SUPPORT NO.104	1	A-1-10	4
			A-1-10	7
367-8202-2	BELLOWS NO.2 WITH METAL	1	A-1-10	1
441-1634-7	PIPETTE NO.57	1	A-1-2	4
			A-1-6	19
442-3460-8	FITTING NO. 9-A	1	A-1-6	18
442-8503-9	TUBING NO.103	1	A-1-11	7
443-0836-6	CHAMBER NO.17	1	A-1-10	6
			A-1-10	9
443-1290-9	PINCH VALVE K-1 ASSY	1	A-1-6	20
443-1362-0	FILTER NO. 9	1	A-1-10	8
443-1411-5	FLOAT NO. 1	1	A-1-10	5
443-1971-6	RELIEF VALVE 247L-1V-1/8Z171	1	A-1-10	2
443-2455-2	AIR FILTER F1000-6-B	1	A-1-10	10
443-2537-1	GLASS CHAMBER GC-37	1	A-1-6	12
443-3169-1	AIR CYLINDER T-2437	1	A-1-6	6
443-6880-2	VACUUM PARTS SET FOR 21Z-PSV	1	A-1-13	3
443-6881-6	PRESSURE PARTS SET FOR 21Z-PSP	1	A-1-13	5
443-6954-1	PISTON PUMP PSL-21Z	1	A-1-13	2
443-8655-5	AIR VALVE WTKV012	1	A-1-8	4
			A-1-8	22
443-8656-9	AIR VALVE WTKV012-E1-PLL-DC12	1	A-1-8	7
			A-1-8	21
443-8657-2	AIR VALVE WTKV013	1	A-1-8	5
443-8660-4	AIR VALVE WTKV011-E1-PLL-DC12	1	A-1-8	8
443-8662-1	END PLATE WTKV010-R	1	A-1-8	10
			A-1-8	27
443-8663-5	END PLATE WTKV010-L	1	A-1-8	9
			A-1-8	26

KX-21 Parts List Code No. Order

Code No.	Description	Unit/Q'ty	Page	Item No.
443-9650-1	AIR VALVE WTKV014	1	A-1-8	3
			A-1-8	25
443-9657-6	AIR VALVE WTKV023-4E1-PLL-DC12	1	A-1-8	2
			A-1-8	24
443-9658-0	AIR VALVE WTKV024-4E1-PLL-DC12	1	A-1-8	6
			A-1-8	23
662-0168-8	PCB NO.6350 WITH ROM	1	A-1-4	13
			A-1-12	2
893-5012-3	TRAP CHAMBER NO. 9 ASY (C2/K45)	UNSATABLE	A-1-10	4-6
903-2291-2	TRANSDUCER NO. 3 ASSY (RBC)	1	A-1-11	3
913-0927-0	DILUENT CHAMBER NO.10 ASSY (C7)	1	A-1-6	15
923-5151-0	SWITCH NO.83 ASSY	1	A-1-2	2
933-3431-0	PU PROTECTION FILTER NO.1 ASSY	UNSATABLE	A-1-10	7-9
933-4591-2	FAN ASSEMBLY NO.19	1	A-1-4	5
953-1211-8	VOLUME WITH WIRING NO.14	1	A-1-2	8
963-3661-9	DIAPHRAGM PUMP ASSY NO.45 (0.5)	1	A-1-11	6
973-2761-6	SRV UNIT KX-21	UNSATABLE	A-1-2	3
973-2771-3	DRIVE MECHANISM NO.58 ASSY	1	A-1-6	17
973-2781-1	SAMPLE ROTOR FIXTURE NO. 6	1	A-1-6	16
973-2791-8	SAMPLE ROTOR VALVE NO.17 ASSY	1	A-1-6	8
973-2801-8	SRV FIXED VALVE NO.28-L ASSY	1	A-1-6	9
973-2811-5	SRV FIXED VALVE NO.28-R ASSY	1	A-1-6	7
973-2821-2	DETECTOR BLOCK KX-21	UNSATABLE	A-1-2	6
973-2831-0	TRANSDUCER NO.8 ASSY	1	A-1-11	4
973-2841-7	HGB UNIT KX-21	1	A-1-11	1
973-2851-4	MASTER VALVE 3MV14-AF ASSY	1	A-1-11	8
973-2861-1	MASTER VALVE 3MV17-C ASSY	1	A-1-11	9
973-2871-9	DIAPHRAGM PUMP ASSY NO.48 (0.25)	1	A-1-11	5
973-2881-6	THERMISTOR ASSY NO.37	1	A-1-11	2
973-2891-3	REGULATOR UNIT KX-21	UNSATABLE	A-1-2	1
			A-1-6	13
973-2901-3	VALVE UNIT-A	UNSATABLE	A-1-4	2
			A-1-8	1
973-2911-1	DIAPHRAGM PUMP ASSY NO.49 (2.0)	1	A-1-6	3
			A-1-8	12
973-2921-8	DIAPHRAGM PUMP ASSY NO.50 (1.0)	1	A-1-6	4
			A-1-8	11
973-2931-5	VALVE UNIT-B	UNSATABLE	A-1-4	1
			A-1-8	20
973-2941-2	DIAPHRAGM PUMP ASSY NO.51 (0.2)	1	A-1-6	2
973-2951-0	DIAPHRAGM PUMP ASSY NO.52 (0.05)	1	A-1-6	5
973-2971-4	WASTE CHAMBER NO.39 ASSY	1	A-1-6	14
973-2981-1	PNEUMATIC UNIT KX-21	UNSATABLE	A-1-6	1
973-2982-5	PNEUMATIC UNIT KX-21 (W/PSL-21	1	A-1-6	1
973-2991-9	OPERATION PANEL KX-21	1	A-1-2	9
973-3001-8	PRINTER UNIT KX-21	UNSATABLE	A-1-2	5*
973-3011-5	FOR JAPANESE MARKET	UNSATABLE	A-1-4	7'
973-3012-9	POWER SUPPLY UNIT (C2/117V)	UNSATABLE	A-1-4	7\$
973-3013-2	POWER SUPPLY UNIT (C3/220V)	UNSATABLE	A-1-4	7#
973-3014-6	POWER SUPPLY UNIT (C4/240V)	UNSATABLE	A-1-4	7*
973-3311-1	ROM 1KX2F ASSY	1	A-1-4	6
973-4531-1	OUTPUT UNIT NO. 1 KX-21	1	A-1-4	14
981-0771-7	KX-21 PNEUMATIC REPLACE KIT	1	A-1-13	PM

## APPENDIX B INSTALLATION PROCEDURES

B.1	PCB DIP SWITCH (S1) SETTING VERIFICATION.....	B-1
B.2	START UP SEQUENCE .....	B-1

## APPENDIX B INSTALLATION PROCEDURES

Follow the installation procedures written in the Operator's Manual. The additional information required for installation is given below.

### B.1 PCB DIP SWITCH (S1) SETTING VERIFICATION

Refer to *Section 4.4.2. PCB No. 6363* for the DIP switch settings.

### B.2 START UP SEQUENCE

After the initial power ON at installation, some system set up are required.

- (1) Priming sequence:  
Access the "Setting Seq." program by selecting 9. Service - 2. Service Seq. - 1. Setting Seq.  
Refer to *Section 5.5.1. Setting Sequence* of this manual for information.
- (2) Date setting:  
Access the "Date/Time" program by selecting 6. Settings - 2. Date/Time.  
Refer to *KX-21 Operator's Manual, Chapter 10* for information.
- (3) Cycle counter reset:  
Access the "initialize" program by selecting 9. Service - 3. Settings - 1. Initialize - 1. Cycle Counter.  
Refer to *Section 5.6.1. Initialize* of this manual for information.

**NOTE:** Cycle counter must be reset after setting the current date, since the date of last maintenance will also be reset.

# SERVICE MANUAL UPDATE RECORD

## MODEL: KX-21

	Ref. ECR/ TB No.	Date Released	Update Info. Summary	Revised Pages	Remarks
1	398E029	98/07/14	Modifying KX-21 for Chinese market.	4-9	MI
2	398E030	98/07/14	Replacing Relief Valve used in KX-21 Regulator Unit	A-1-10	MI
3	TB98034	98/08/05	A description in Error Message "Analysis Error [Detect Sensitivity Error (Electrical Conductivity)] was incorrect.	6-36	RH
4	398C005	98/08/17	Changing the model name of Printer on KX-21 and K-4500.	A-1-12	FT
5	398G045	98/09/14	Modifying Pneumatic Unit KX-21 for noise reduction	A-1-13	MI
6	398G031	98/09/16	Countermeasure for the KX-21 CPU Board not to start up when Power-ON.	A-1-4, A-1-5	FT
7	398G038	98/09/22	Countermeasure for reagent consumption and pressure error on KX-21. (Version up to 00-09)	7-6, 7-7, 7-8, 7-9	FT
8	398J015 (398J028)	99/01/25	Changing Diaphragm Pump (1 mL, 2 mL) of KX-21	A-1-9	MH
9	398G072	99/02/24	Changing the KX-21 Detector Block tubing	7-2	MI
10	TB 99003	99/03/02	KX-21 Service Manual correction	General TOC (ii), Sec. 2 TOC, 2-6 thru 2-64, 5-11 thru 5-13, 6-7, 7-3, A-1-2, A-1-3, A-1-9, A-1-11	MI
11	398J044	99/04/14	WL Flag Increase of KX-21	7-2	MH
12	399B093	99/04/15	Updating KX-21 program ROM 1KX2F to version 00-12.	5-12	MI
13	399B017	99/05/18	Changing KX-21 Pneumatic Unit	A-1-1, A-1-7, A-1-13, A-1-14, A-1-15, A-3-1, A-3-2, A-4-1, A-4-2	MH
14	398L021	99/06/14	Changing the length of SRV rinse line tube to prevent leakage	7-2	MI
15	399B017R (398K065)	99/12/06	Changing KX-21 Pneumatic Unit	A-1-1, A-1-7, A-1-13, A-1-14, A-1-15, A-3-1, A-3-2, A-4-1, A-4-2	MH
16	TB99045	99/12/14	Updating KX-21 Parts List	A-1-2, A-1-3, A-1-11	JH
17	399K024	00/01/25	Changing tubing arrangement in Detector Block to prevent high WBC background.	A-1-11	MI



# SERVICE MANUAL

Automated Blood Coagulation Analyzer

# KX-21

- SECTION 1 SPECIFICATIONS
- SECTION 2 HYDRAULICS AND MECHANICAL SYSTEM
- SECTION 3 ELECTRONICS
- SECTION 4 ADJUSTMENT
- SECTION 5 MAINTENANCE PROGRAMS
- SECTION 6 ERROR MESSAGE AND TROUBLESHOOTING
- SECTION 7 SCHEMATICS
- APPENDIX A PARTS LIST
- APPENDIX B INSTALLATION PROCEDURES



# KX-21 SERVICE MANUAL

## GENERAL CONTENTS

### SECTION 1 SPECIFICATIONS

1.1	NAME AND MODEL NUMBER .....	1-1
1.2	SYSTEM ORGANIZATION AND DIMENSIONS .....	1-1
	1.2.1 Configuration.....	1-1
	1.2.2 Expandability.....	1-1
1.3	ELECTRICAL RATINGS.....	1-1
	1.3.1 Rated Voltage.....	1-1
	1.3.2 Line Frequency .....	1-1
	1.3.3 Power Consumption .....	1-1
1.4	DIMENSIONS AND WEIGHT.....	1-1
1.5	INTENDED USE.....	1-2
1.6	PERFORMANCE SPECIFICATIONS .....	1-2
	1.6.1 Analysis and Display Range .....	1-2
	1.6.2 Accuracy .....	1-3
	1.6.3 Reproducibility.....	1-3
	1.6.4 Linearity .....	1-3
	1.6.5 Carryover.....	1-4
	1.6.6 Stability .....	1-4
	1.6.7 Throughput.....	1-5
	1.6.8 Required Sample and Reagent Volumes .....	1-5
	1.6.9 Graphic LCD/Panel Keyboard .....	1-5
1.7	FUNCTIONS .....	1-6
	1.7.1 Data Storage.....	1-6
	1.7.2 Built-in Printer (Optional).....	1-6
	1.7.3 Serial Interface (Optional).....	1-6
	1.7.4 Histogram Analysis.....	1-6
	1.7.5 Quality Control.....	1-6
	1.7.6 Calibration .....	1-7
	1.7.7 Abnormality Detection Function .....	1-7
1.8	START-UP.....	1-8
1.9	SHUT DOWN .....	1-8
1.10	MAINTENANCE .....	1-9
1.11	SAFETY PROTECTION.....	1-9
1.12	ACOUSTIC NOISE .....	1-9
1.13	ENVIRONMENTAL REQUIREMENTS .....	1-10
1.14	REAGENTS.....	1-10

## SECTION 2    HYDRAULICS AND MECHANICAL SYSTEM

2.1	HYDRAULIC SYSTEM BLOCK DIAGRAM.....	2-1
2.1.1	Block Diagram (Whole Blood Mode).....	2-1
2.1.2	Block Diagram (Pre-diluted Mode).....	2-1
2.2	ANALYSIS FLOW.....	2-2
2.2.1	WBC/HGB Analysis Flow.....	2-2
2.2.2	RBC/PLT Analysis Flow.....	2-2
2.3	SAMPLE FLOW IN SRV.....	2-3
2.3.1	Sample Path.....	2-3
2.3.2	Sample Path (Whole Blood Mode).....	2-4
2.3.3	Sample Path (Pre-diluted Mode).....	2-4
2.4	SOLENOID VALVE LOCATION.....	2-5
2.4.1	Valve Unit Tubing Connections.....	2-6
2.5	DIAPHRAGM PUMP LOCATION.....	2-8
2.6	PNEUMATIC SYSTEM.....	2-9
2.6.1	Sample Aspiration System.....	2-9
2.6.2	Vacuum System.....	2-9
2.6.3	Pressure System.....	2-10
2.7	WASTE CHAMBER TUBING.....	2-10
2.8	RINSE CUP.....	2-11
2.9	RBC DETECTOR UNIT.....	2-12
2.10	WBC DETECTOR UNIT.....	2-12
2.11	SRV UNIT.....	2-13
2.12	HYDRAULIC FLOW DESCRIPTION.....	2-14
2.12.1	Whole Blood Mode.....	2-14
2.12.2	Pre-Diluted Mode.....	2-56
2.13	PNEUMATIC & HYDRAULIC PARTS.....	2-60

## SECTION 3    ELECTRONICS

3.1	PCB LOCATION.....	3-1
3.2	BLOCK DIAGRAM.....	3-2
3.3	PCB NO. 2135 (ANALOG MAIN).....	3-4
3.4	PCB NO. 6363 (MAIN CPU).....	3-8
3.5	PCB NO. 6350 (PRINTER DRIVER BOARD).....	3-15
3.6	POWER SUPPLY UNIT (PCB NO. 4087).....	3-17

## SECTION 4 ADJUSTMENT

4.1	STANDARD SENSITIVITY ADJUSTMENT.....	4 - 1
4.1.1	WBC and RBC Sensitivity Adjustment.....	4 - 1
4.1.2	PLT Sensitivity Adjustment.....	4 - 3
4.2	HGB ADJUSTMENT.....	4 - 5
4.3	CLOG LEVEL ADJUSTMENT.....	4 - 7
4.4	PCB CHECKING AND ADJUSTMENT.....	4 - 8
4.4.1	PCB No. 2135 (Analog Main).....	4 - 8
4.4.2	PCB No. 6363 (Main CPU).....	4 - 9
4.4.3	PCB No. 4087 (Power Supply Unit).....	4 - 10
4.5	PROGRAM VERSION UP PROCEDURES.....	4 - 11
4.6	MECHANICAL PARTS ADJUSTMENT.....	4 - 12
4.6.1	SRV Position Adjustment.....	4 - 12
4.6.2	Rinse Cup Position Adjustment.....	4 - 13

## SECTION 5 MAINTENANCE PROGRAMS

5.1	SPECIAL MODES.....	5-1
5.2	ENTERING THE MAINTENANCE MODES.....	5-1
5.2.1	Maintenance Mode.....	5-1
5.2.2	Factory Maintenance Mode.....	5-1
5.2.3	Access to Maintenance Modes.....	5-2
5.3	MENU CONFIGURATION.....	5-3
5.4	CLOG REMOVAL.....	5-4
5.5	SERVICE SEQUENCE.....	5-4
5.5.1	Setting Sequence.....	5-5
5.5.2	Deprime Sequence.....	5-5
5.5.3	Gain Adjustment.....	5-6
5.5.4	Control Mode.....	5-6
5.5.5	Calibrator Mode.....	5-6
5.5.6	Continuous Mode.....	5-7
5.5.7	Clog Adjustment (Clog Voltage Adjustment Sequence).....	5-7
5.6	SETTINGS.....	5-8
5.6.1	Initialize.....	5-8
5.6.2	Change.....	5-9
5.6.2.1	Calibration.....	5-10
5.6.2.2	Hardware Limit.....	5-11
5.6.2.3	Parameters (Other Settings).....	5-12
5.7	TEST OPERATION.....	5-13
5.7.1	DP Test Operation.....	5-13
5.7.2	SV Test Operation.....	5-14
5.7.3	HC Test Operation (Optional).....	5-14
5.7.4	IP (Internal Printer) Test Operation (Optional).....	5-14

5.8 SERVICE DATA.....	5-15
5.8.1 Status Display (Sensor & SV Status) .....	5-16
5.9 SPECIAL SEQUENCE .....	5-17
5.9.1 Factory Rinse Sequence.....	5-17
5.9.2 Shipping Sequence .....	5-17
5.9.3 Factory Initialize .....	5-17
5.9.4 Factory Settings .....	5-19
5.9.5 Raw Data Output.....	5-19
5.9.6 Debugger.....	5-19
5.10 PRINT SETTINGS.....	5-19

## SECTION 6 ERROR MESSAGE AND TROUBLESHOOTING

6.1 INTRODUCTION .....	6-1
6.1.1 [HELP] Key Function.....	6-1
6.1.2 Action Message Screen.....	6-3
6.1.3 Error Code Function.....	6-3
6.2 SENSOR LOCATION .....	6-4
6.3. ERROR MESSAGE .....	6-5
6.3.1 Pressure.....	6-5
6.3.1.1 Pressure/Vac Error [0.5 kg/cm <sup>2</sup> Pressure Error] .....	6-5
6.3.1.2 Pressure/Vac Error [250 mmHg Vacuum Error].....	6-6
6.3.1.3 Pressure/Vac Error [Pressure Lower Error].....	6-8
6.3.2 Chamber.....	6-10
6.3.2.1 Waste Not Draining .....	6-10
6.3.2.2 Replenish Diluent.....	6-12
6.3.2.3 Replenish Lyse.....	6-14
6.3.3 Built-in Printer .....	6-16
6.3.3.1 No Printer Paper.....	6-16
6.3.3.2 Printer Error .....	6-18
6.3.4 Motor .....	6-20
6.3.4.1 Rinse Motor Error [Rinse Motor Function Error].....	6-20
6.3.5 Temperature.....	6-22
6.3.6.1 Room Temp. High .....	6-22
6.3.6.2 Room Temp. Low.....	6-22

6.3.6	Analysis .....	6 - 24
6.3.6.1	Background Error.....	6 - 24
6.3.6.2	Sampling Error [RBC Sampling Error].....	6 - 26
6.3.6.3	Sampling Error [PLT Sampling Error].....	6 - 26
6.3.6.4	Sampling Error [WBC Sampling Error].....	6 - 26
6.3.6.5	Sampling Error [RBC CCSD Noise Error].....	6 - 28
6.3.6.6	Sampling Error [PLT CCSD Noise Error].....	6 - 28
6.3.6.7	Sampling Error [WBC CCSD Noise Error].....	6 - 28
6.3.6.8	HGB Error .....	6 - 30
6.3.6.9	WBC Aperture Clog.....	6 - 32
6.3.6.10	RBC Aperture Clog.....	6 - 32
6.3.6.11	Analysis Error [WBC/HGB Error (Tri-modal Particle)].....	6 - 34
6.3.6.12	Analysis Error [Detect Sensitivity Error (Electrical Conductivity)].....	6 - 36
6.3.7	Memory .....	6 - 38
6.3.7.1	Memory Error [RAM Error].....	6 - 38
6.3.7.2	Memory Error [ROM Error].....	6 - 38
6.3.7.3	Setup Data Error.....	6 - 40
6.2.7.4	Print Error .....	6 - 42
6.3.8	External Output.....	6 - 44
6.3.8.1	HOST Comm. Error.....	6 - 44
6.3.9	QC .....	6 - 46
6.3.9.1	QC Error [L-J Control Error].....	6 - 46
6.3.9.2	QC Error [Control Error].....	6 - 46
6.3.9.3	Calibration Error.....	6 - 48
6.3.10	Maintenance.....	6 - 50
6.3.10.1	Clean SRV .....	6 - 50
6.3.10.2	Clean W. Chamber (Clean Waste Chamber.).....	6 - 52
6.3.10.3	Clean Transducer.....	6 - 54

## SECTION 7 SCHEMATICS

KX-21 WIRING DIAGRAM.....	7-1
KX-21 TUBING DIAGRAM .....	7-2
KX-21 Hydraulic Diagram.....	7-3
KX-21 Power Supply Unit (100V) Diagram.....	7-4
KX-21 POWER SUPPLY UNIT (200V) DIAGRAM.....	7-5
KX-21 TIMING CHART (1/7).....	7-6
KX-21 TIMING CHART (2/7).....	7-7
KX-21 TIMING CHART (3/7).....	7-8
KX-21 TIMING CHART (4/7).....	7-9
KX-21 TIMING CHART (5/7).....	7-10
KX-21 TIMING CHART (6/7).....	7-11
KX-21 TIMING CHART (7/7).....	7-12

## APPENDIX A PARTS LIST

## APPENDIX B INSTALLATION PROCEDURES

B.1 PCB DIP SWITCH (S1) SETTING VERIFICATION.....	B-1
B.2 START UP SEQUENCE .....	B-1

## SECTION 1 SPECIFICATIONS

1.1	NAME AND MODEL NUMBER .....	1-1
1.2	SYSTEM ORGANIZATION AND DIMENSIONS .....	1-1
	1.2.1 Configuration.....	1-1
	1.2.2 Expandability.....	1-1
1.3	ELECTRICAL RATINGS.....	1-1
	1.3.1 Rated Voltage.....	1-1
	1.3.2 Line Frequency .....	1-1
	1.3.3 Power Consumption .....	1-1
1.4	DIMENSIONS AND WEIGHT.....	1-1
1.5	INTENDED USE .....	1-2
1.6	PERFORMANCE SPECIFICATIONS .....	1-2
	1.6.1 Analysis and Display Range .....	1-2
	1.6.2 Accuracy .....	1-3
	1.6.3 Reproducibility.....	1-3
	1.6.4 Linearity .....	1-3
	1.6.5 Carryover.....	1-4
	1.6.6 Stability .....	1-4
	1.6.7 Throughput.....	1-5
	1.6.8 Required Sample and Reagent Volumes.....	1-5
	1.6.9 Graphic LCD/Panel Keyboard .....	1-5
1.7	FUNCTIONS .....	1-6
	1.7.1 Data Storage.....	1-6
	1.7.2 Built-in Printer (Optional).....	1-6
	1.7.3 Serial Interface (Optional).....	1-6
	1.7.4 Histogram Analysis.....	1-6
	1.7.5 Quality Control.....	1-6
	1.7.6 Calibration .....	1-7
	1.7.7 Abnormality Detection Function.....	1-7
1.8	START-UP.....	1-8
1.9	SHUT DOWN .....	1-8
1.10	MAINTENANCE .....	1-9
1.11	SAFETY PROTECTION.....	1-9
1.12	ACOUSTIC NOISE .....	1-9
1.13	ENVIRONMENTAL REQUIREMENTS .....	1-10
1.14	REAGENTS.....	1-10

## SECTION 1 SPECIFICATIONS

### 1.1 NAME AND MODEL NUMBER

Name: Automated Hematology Analyzer  
Model: KX-21

### 1.2 SYSTEM ORGANIZATION AND DIMENSIONS

#### 1.2.1 Configuration

KX-21 Main Unit  
Built-in Printer (Optional)

#### 1.2.2 Expandability

RS-232C Serial Interface (Optional)

### 1.3 ELECTRICAL RATINGS

#### 1.3.1 Rated Voltage

Input Voltage:  
AC 100V/117V/220V/230V/240V $\pm$ 10%

Output Voltage:

DC $\pm$ 15 $\pm$ 0.75 V	0.5 A
DC +100 $\pm$ 3 V	0.02 A
DC +15 $\pm$ 0.1 V	2.0 A
DC +12 $\pm$ 0.2 V	3.0 A
DC +24 $\pm$ 1.2 V	0.7 A
AC 100 V	1.2 A

Rated Voltage: AC 100V, 117V, 220V, 240V $\pm$ 10%

The KX-21 supports two types of power supplies (100 V and 200 V).  
The input voltage can be switched between 100 V and 117 V, or between 220 V and 240 V,  
depending on the power supply's internal settings.

#### 1.3.2 Line Frequency

50 Hz or 60 Hz

#### 1.3.3 Power Consumption

230 VA or less

### 1.4 DIMENSIONS AND WEIGHT

Dimensions: 420 (W) x 355 (D) x 480 (H) mm  
Weight: Approx. 28 kg

**NOTE:** The acceptable dimensional difference is within 3% of the values listed above.  
Protrusions are not included in the above dimensions. The acceptable weight difference is  
within 10% of the values listed above.

## 1.5 INTENDED USE

The KX-21 is intended for in vitro diagnostic use, analyzing 18 parameters in anti-coagulated human blood.

The anti-coagulants are EDTA-2K, EDTA-3K and EDTA-2Na. The Anti-coagulant volume conforms to NCCLS standards.

## 1.6 PERFORMANCE SPECIFICATIONS

### 1.6.1 Analysis and Display Range

#### (1) Analysis Range

WBC:	1.0 - 99.9 x 10 <sup>3</sup> /μL
RBC:	0.30 - 7.00 x 10 <sup>6</sup> /μL
HGB:	0.1 - 25.0 g/dL
HCT:	10.0 - 60.0%
PLT:	10 - 999 x 10 <sup>3</sup> /μL

#### (2) Display Range

WBC:	0 - 299.9 x 10 <sup>3</sup> /μL
RBC:	0 - 19.99 x 10 <sup>6</sup> /μL
HGB:	0.0 - 25.0 g/dL
HCT:	0.0 - 99.9%
MCV:	0.0 - 299.9 fL
MCH:	0.0 - 99.9 pg
MCHC:	0.0 - 99.9 g/dL
PLT:	0 - 1999 x 10 <sup>3</sup> /μL

W-SCR or LYMPH%:	0 - 100.0%
W-MCR or MXD%:	0 - 100.0%
W-LCR or NEUT%:	0 - 100.0%
W-SCC or LYMPH#:	0 - 299.9 x 10 <sup>3</sup> /μL
W-MCC or MXD#:	0 - 299.9 x 10 <sup>3</sup> /μL
W-LCC or NEUT#:	0 - 299.9 x 10 <sup>3</sup> /μL
RDW-CV:	0.0% - 100.0%
RDW-SD:	0 - 250 fL
PDW:	0 - 40.0 fL
MPV:	0 - 40.0 fL
P-LCR:	0 - 100.0%

WBC Histogram	0 - 300 fL
RBC Histogram	0 - 250 fL
PLT Histogram	0 - 40 fL



### 1.6.2 Accuracy

When control blood or calibrator is analyzed 10 times consecutively, the mean difference from the value obtained on the standard instrument should be within the following range:

- Whole Blood Mode
  - WBC                      Within  $\pm 3\%$  or  $\pm 0.2 \times 10^3/\mu\text{L}$
  - RBC                      Within  $\pm 2\%$  or  $\pm 0.03 \times 10^6/\mu\text{L}$
  - PLT                      Within  $\pm 5\%$  or  $\pm 10 \times 10^3/\mu\text{L}$
  
- Pre-diluted Mode
  - WBC                      Within  $\pm 5\%$  or  $\pm 0.3 \times 10^3/\mu\text{L}$
  - RBC                      Within  $\pm 3\%$  or  $\pm 0.05 \times 10^6/\mu\text{L}$
  - PLT                      Within  $\pm 8\%$  or  $\pm 15 \times 10^3/\mu\text{L}$

### 1.6.3 Reproducibility

When fresh normal blood or control blood is analyzed in Whole Blood mode 10 times consecutively, the variation of coefficient under 95% confidence interval should be within the following range:

Parameter	Condition	Whole Blood Mode	Pre-diluted Mode
WBC	$4.0 \times 10^3/\mu\text{L}$	3.5% or lower	6.0% or lower
RBC	$4.00 \times 10^6/\mu\text{L}$	2.5% or lower	3.0% or lower
HGB		1.5% or lower	2.5% or lower
HCT		2.0% or lower	3.0% or lower
MCV		2.0% or lower	3.0% or lower
MCH		2.0% or lower	3.0% or lower
MCHC		2.0% or lower	3.0% or lower
PLT	$100 \times 10^3/\mu\text{L}$	6.0% or lower	9.0% or lower
W-SCR		15.0% or lower	25.0% or lower
W-MCR	W-MCR 12% or more	30.0% or lower	45.0% or lower
W-LCR		15.0% or lower	25.0% or lower
W-SCC		15.0% or lower	25.0% or lower
W-MCC	W-MCC $1.0 \times 10^3/\mu\text{L}$	30.0% or lower	45.0% or lower
W-LCC		15.0% or lower	25.0% or lower
RDW-CV		4.0% or lower	6.0% or lower
RDW-SD		4.0% or lower	6.0% or lower
PDW		12.0% or lower	18.0% or lower
MPV		5.0% or lower	7.5% or lower
P-LCR		20.0% or lower	30.0% or lower

### 1.6.4 Linearity

When the whole blood manual mode analysis is executed, the difference from the theoretical value should be within the following range:

WBC:	1.0 - 99.9 $\times 10^3/\mu\text{L}$	(Within $\pm 0.3 \times 10^3/\mu\text{L}$ or $\pm 3\%$ )
RBC:	0.30 - 7.00 $\times 10^6/\mu\text{L}$	(Within $\pm 0.03 \times 10^6/\mu\text{L}$ or $\pm 3\%$ )
HGB:	0.1 - 25.0 g/dL	(Within $\pm 0.2$ g/dL or $\pm 2\%$ )
HCT:	10.0 - 60.0%	(Within $\pm 1.0$ HCT% or $\pm 3\%$ )
PLT:	10 - 999 $\times 10^3/\mu\text{L}$	(Within $\pm 10 \times 10^3/\mu\text{L}$ or $\pm 5\%$ )
	(When RBC $< 7.00 \times 10^6/\mu\text{L}$ )	

### 1.6.5 Carryover

When normal fresh blood or control blood is analyzed, the carryover rate obtained by standard analysis should be within the following range:

WBC	3% or less
RBC	1.5% or less
HGB	1.5% or less
HCT	1.5% or less
PLT	5% or less

### 1.6.6 Stability

When normal fresh blood or control blood is analyzed, the stability should be within the following range:

#### (1) Stability relative to Temperature

In normal fresh blood or control blood analysis, the data fluctuation while the ambient temperature changes from 15°C to 30°C should be within the following range:

The following data are based on the assumption that the sample is analyzed within 12 hours after collection, and that any change in the sample should be excluded from the fluctuation ratio.

WBC	Within 10% or $0.05 \times 10^3/\mu\text{L}$
RBC	Within 5%
HGB	Within 5%
HCT	Within 5%
PLT	Within 15% or $30 \times 10^3/\mu\text{L}$

#### (2) Within-a-Day Stability

In control blood analysis of 5°C or less ambient temperature change, the data fluctuation for 24 hours after startup should be within the following range:

WBC	Within 10%
RBC	Within 5%
HGB	Within 5%
HCT	Within 5%
PLT	Within 15% or $30 \times 10^3/\mu\text{L}$

#### (3) Day-to-Day Stability

In control blood analysis of 5°C or less ambient temperature change, the data fluctuation for ten days should be within the following range:

WBC	Within 10%
RBC	Within 5%
HGB	Within 5%
HCT	Within 5%
PLT	Within 15% or $30 \times 10^3/\mu\text{L}$

#### (4) Stability relative to Power Supply Voltage

In control blood analysis of 5°C or less ambient temperature change, the data fluctuation while the power supply voltage changes 10% from the rated voltage should be within the following range:

WBC	Within 10%
RBC	Within 5%
HGB	Within 5%
HCT	Within 5%
PLT	Within 15% or $30 \times 10^9/\mu\text{L}$

#### 1.6.7 Throughput

Approx. 60 seconds/sample  
Approx. 60 samples/hour

#### 1.6.8 Required Sample and Reagent Volumes

	Whole Blood Mode	Pre-diluted Mode	Shutdown
Sample Volume	approx. 50 $\mu\text{L}$	approx. 20 $\mu\text{L}$ (200 $\mu\text{L}$ of 1:26 diluted sample is aspirated.)	---
Diluent	approx. 34 mL/sample	approx. 34 mL/sample	approx. 200 mL/ cycle
Lyse reagent	approx. 1.0 mL/sample	approx. 1.0 mL/sample	approx. 5 mL/ cycle
Detergent	---	---	approx. 0.3 mL/cycle

#### 1.6.9 Graphic LCD/Panel Keyboard

##### 1.6.9.1 Graphic LCD Panel Display

- 320 x 240 dots (dot pitch: 0.36 x 0.36 mm)
- With backlight
- Display Area: 115.17 x 86.37 mm

##### 1.6.9.2 Graphic LCD Display Items

- Date/Time
- Sample ID No.
- Analysis results including flag
- Error messages
- Instrument status
- Service data
- Select Menu
- Analysis mode

##### 1.6.9.3 Used Languages

- Panel Keyboard English
- LCD Display English, Chinese or Japanese
- Printer English
- Labels English, Chinese or Japanese

## 1.7 FUNCTIONS

### 1.7.1 Data Storage

- (1) Analysis Results: 240 samples
- (2) Histograms: None
- (3) Quality Control Data: 60 points (in 6 files)
- (4) Preset Values
- (5) Maintenance Data
  - 1) Instrument Operation Cycle Count
  - 2) Unit Operation Cycle:  
Stores the number of operations after the replacement or maintenance of Waste Chamber, Detector and SRV.
  - 3) Error History:  
Can be output to host computer, but not displayed on LCD.

### 1.7.2 Built-in Printer (Optional)

#### 1.7.2.1 Printer Specification

- Thermal printer
- Model: FTP-421MCL001 (Compatible with K-4500/F-820)
- Control board: PCB No. 6350
- Thermal paper, 60 mm width

#### 1.7.2.2 Printed Items

- Date/Time
- Sample ID No.
- Analysis results including flag
- QC data
- Service data
- Set Values

### 1.7.3 Serial Interface (Optional)

- 1 port of RS-232C Serial Interface is provided to output the following data to host computer.
  - The latest analysis results
  - Stored data
  - QC data

### 1.7.4 Histogram Analysis

Discriminator position on the latest analysis can be manually changed.

### 1.7.5 Quality Control

- $\bar{X}$  Control or L-J Control

Up to 60 points of control data can be stored for 6 types of samples (in 6 files).  
8 control parameters can be selected.  
The control limit can be manually set.  
Sample for quality control: EIGHTCHECK-3WP, EIGHTCHECK-3WPXTRA

## **1.7.6 Calibration**

### **1.7.6.1 Customer Calibration**

- |                            |  |
|----------------------------|--|
| 1) Calibration Method:     | Manual calibration, Auto calibration                     |
| 2) Calibration Mode:       | Whole Blood Mode   |
| 3) Calibration Parameters: | HGB, HCT (Others)<br>WBC, RBC, HGB, HCT, PLT (N.A. only) |
| 4) Calibration Samples:    | Fresh normal blood samples<br>SCS-1000 (N.A. only)       |

### **1.7.6.2 Factory Calibration**

Calibration is performed with the same method as the service calibration, using 3WP-REFERENCE MATERIAL.

## **1.7.7 Abnormality Detection Function**

### **1.7.7.1 Error Alerting Function**

Monitors the abnormalities in the followings, and alert with error messages with alarm when any abnormality is detected.

- (1) Hydraulic System and Mechanical System
  - Reagent level in the internal reservoir chambers
  - Fluid level in the waste chambers
  - Pressure and vacuum
  - Rinse cup operation
  - Others
- (2) Analysis Condition
  - Sampling data
  - HGB detection
  - Temperature
  - Clog
- (3) Electricity
  - Sub-Processor Operation
  - Serial interface connection
  - Built-in printer connection
  - Built-in printer paper
- (4) Others
  - Calibration
  - Quality Control

### **1.7.7.2 Histogram Abnormality**

Monitors the abnormalities in the histograms, and add a flag to abnormal data. Refer to the Operator's Manual for the details.

- (1) WL, RL, PL: Relative height at Lower Discriminator exceeds the preset limit.
- (2) WU, RU, PU: Relative height at Upper Discriminator exceeds the preset limit.
- (3) DW: The RBC histogram does not cross the 20% height level twice.
- (4) MP: Two or more peaks exist in RBC or PLT histogram.
- (5) T1: The trough discriminator cannot be set between SCR and MCR populations.
- (6) T2: The trough discriminator cannot be set between MCR and LCR populations.
- (7) F1, F2, F3: Relative height at the trough discriminator exceeds the preset limit.

### 1.7.7.3 Analysis Results Abnormality

Monitors the abnormalities in the analysis results, and add a flag to abnormal data. Refer to the Operator's Manual for the details.

- (1) + or -: An analysis result exceeded the preset Patient Mark Limit.
- (2) \*: An analysis result exceeded the Linearity Limit.

### 1.7.7.4 Imitation Reagents

Reagent specification is monitored as below.

#### (1) Diluent

Monitors the conductivity of diluent if it differs 10% or more compared with that of CELLPACK.

When abnormality is detected, alert with error message "RBC Analysis Error".

#### (2) Lyse reagent

Monitors WBC histogram if mono-peak or two-peak histogram is detected for 11 consecutive samples.

When abnormality are detected, alert with error message "WBC Analysis Error".

The data reporting when abnormality is detected can be set by DIP SW in two levels:

- Level 1: The related data will not be displayed.
- Level 2: The related data will be displayed with an asterisk (\*).

## 1.8 START-UP

(1) System Check including position initialization of mechanical parts.

(2) Auto Rinse

(3) Background Check

The background check limit is as follows: The background check can be repeated up to three times.

WBC <  $0.3 \times 10^3/\mu\text{L}$   
RBC <  $0.02 \times 10^6/\mu\text{L}$   
HGB < 0.1 g/dL  
PLT <  $10 \times 10^3/\mu\text{L}$

## 1.9 SHUT DOWN

The hydraulic system is cleaned with diluted CELLCLEAN aspirated from the whole blood pipette.

To shut down the system, press the [Shutdown] key.

## 1.10 MAINTENANCE

- (1) Customer maintenance
  - 1) Reagent replacement sequence
  - 2) Auto rinse with background check sequence
  - 3) Settings sub-menu for customer system set up
  - 4) Waste chamber cleaning sequence
  - 5) Transducer cleaning sequence
  - 6) Transducer fluid draining sequence (for clog removal)
  - 7) Status display
    - HGB convert (real time)
    - Pressure and vacuum (real time)
    - Unit operation counter
  - 8) Paper feed (optional built-in printer)
- (2) Special Sequences (Service purpose only)
  - 1) Clog removal
  - 2) Setting sequence (Install)
  - 3) Deprime sequence
  - 4) Gain adjustment
  - 5) Control mode
  - 6) Calibrator mode
  - 7) Continuous mode
  - 8) Clog adjustment
  - 9) Initialize/Change/Print setting values
- (3) Special Sequences (Production & R&D purpose only)
  - 1) Factory rinse sequence
  - 2) Shipping sequence
  - 3) Factory initialize/Factory settings
  - 4) Raw data output
  - 5) Debugger
- (4) Test Operation (Service purpose only)
  - 1) Diaphragm test operation
  - 2) SV test operation
  - 3) HC output test (optional)
  - 4) Built-in printer output test (optional)
- (5) Service Information Display (Service purpose only)
  - 1) Temperature
  - 2) Operation status
  - 3) Sampling data
  - 4) Service data

## 1.11 SAFETY PROTECTION

Main Unit Power Supply : Fuse

## 1.12 ACOUSTIC NOISE

55 dB or less

### 1.13 ENVIRONMENTAL REQUIREMENTS

- (1) Ambient Temperature: 15 ~ 30°C  
(The reagent temperature should also be within this range.)
- (2) Relative Humidity: 30% ~ 85%
- (3) Atmospheric Pressure: 70 ~ 106 Kpa
- (4) Installation Condition: Avoid installation in a place where the instrument may be exposed to direct sunlight, dust, vibration or acid.

### 1.14 REAGENTS

Diluent: CELLPACK  
Lyse reagent: STROMATOLYSER-WH  
Detergent: CELLCLEAN

**NOTE:** See Section 1.6.8 for reagent consumption.



## SECTION 2 HYDRAULICS AND MECHANICAL SYSTEM

2.1	HYDRAULIC SYSTEM BLOCK DIAGRAM.....	2-1
	2.1.1 Block Diagram (Whole Blood Mode).....	2-1
	2.1.2 Block Diagram (Pre-diluted Mode).....	2-1
2.2	ANALYSIS FLOW.....	2-2
	2.2.1 WBC/HGB Analysis Flow.....	2-2
	2.2.2 RBC/PLT Analysis Flow.....	2-2
2.3	SAMPLE FLOW IN SRV.....	2-3
	2.3.1 Sample Path.....	2-3
	2.3.2 Sample Path (Whole Blood Mode).....	2-4
	2.3.3 Sample Path (Pre-diluted Mode).....	2-4
2.4	SOLENOID VALVE LOCATION.....	2-5
<b>A</b>	2.4.1 Valve Unit Tubing Connections.....	2-6
2.5	DIAPHRAGM PUMP LOCATION.....	2-8
2.6	PNEUMATIC SYSTEM.....	2-9
	2.6.1 Sample Aspiration System.....	2-9
	2.6.2 Vacuum System.....	2-9
	2.6.3 Pressure System.....	2-10
2.7	WASTE CHAMBER TUBING.....	2-10
2.8	RINSE CUP.....	2-11
2.9	RBC DETECTOR UNIT.....	2-12
2.10	WBC DETECTOR UNIT.....	2-12
2.11	SRV UNIT.....	2-13
<b>A</b>	2.12 HYDRAULIC FLOW DESCRIPTION.....	2-14
	2.12.1 Whole Blood Mode.....	2-14
	2.12.2 Pre-Diluted Mode.....	2-56
<b>A</b>	2.13 PNEUMATIC & HYDRAULIC PARTS.....	2-60

## SECTION 2 HYDRAULICS AND MECHANICAL SYSTEM

### 2.1 HYDRAULIC SYSTEM BLOCK DIAGRAM

#### 2.1.1 Block Diagram (Whole Blood Mode)

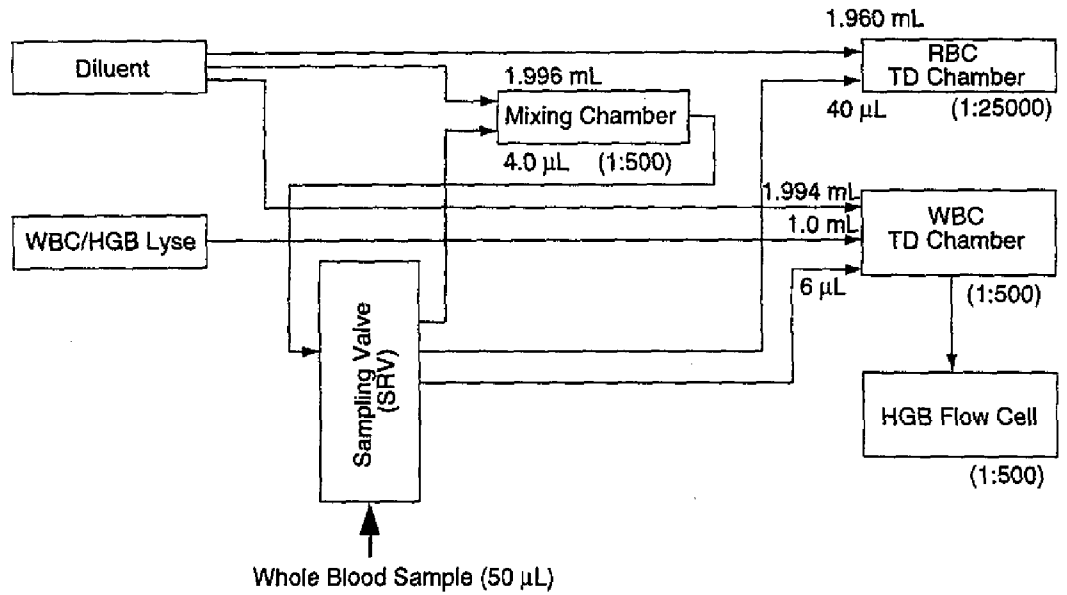

Figure 2-1 Whole Blood Mode Block Diagram

#### 2.1.2 Block Diagram (Pre-diluted Mode)

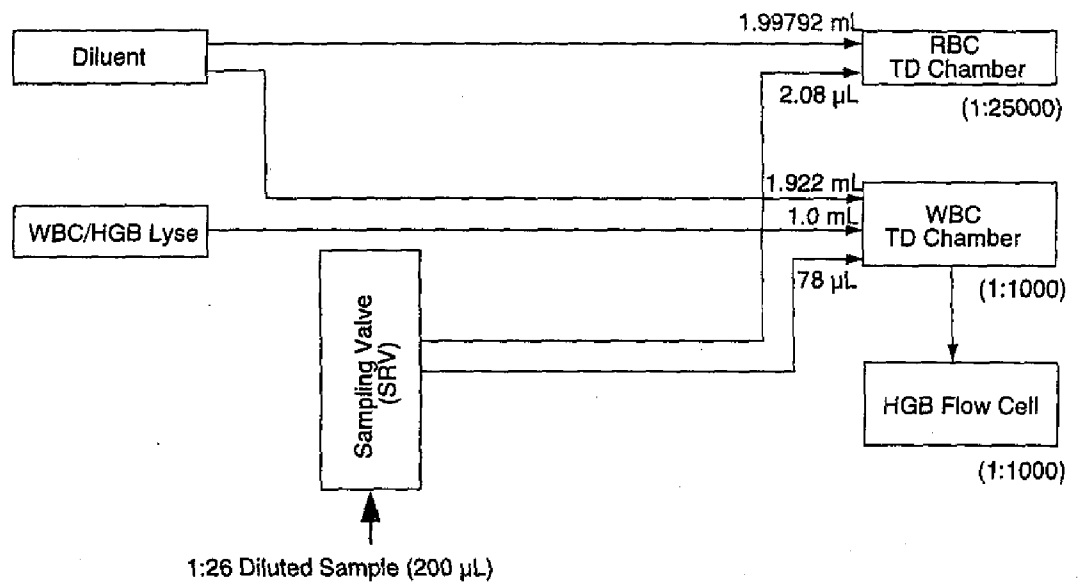
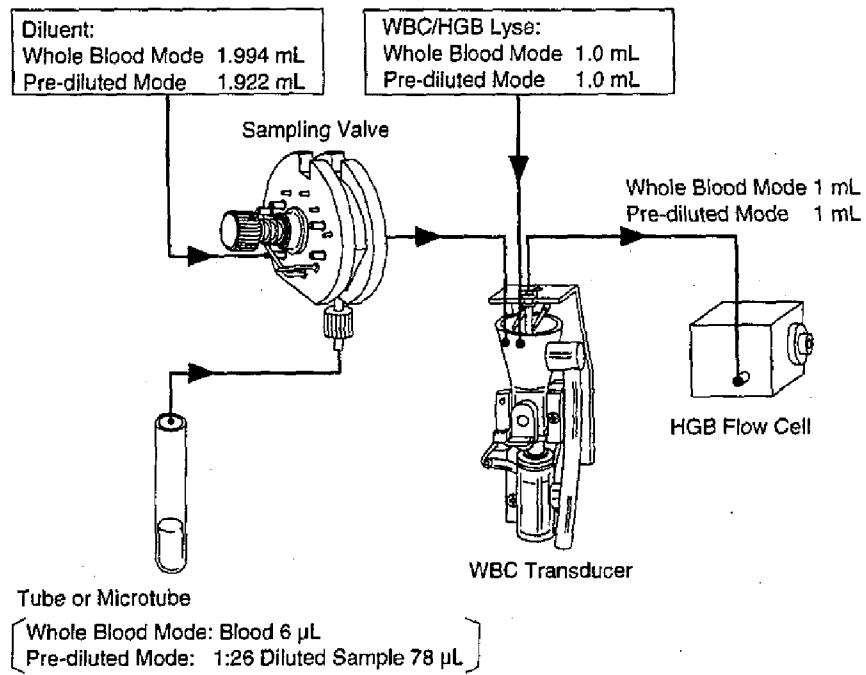

Figure 2-2 Pre-diluted Mode Block Diagram

**2.2 ANALYSIS FLOW**  
**2.2.1 WBC/HGB Analysis Flow**



**Figure 2-3 WBC/HGB Analysis Flow**

**2.2.2 RBC/PLT Analysis Flow**

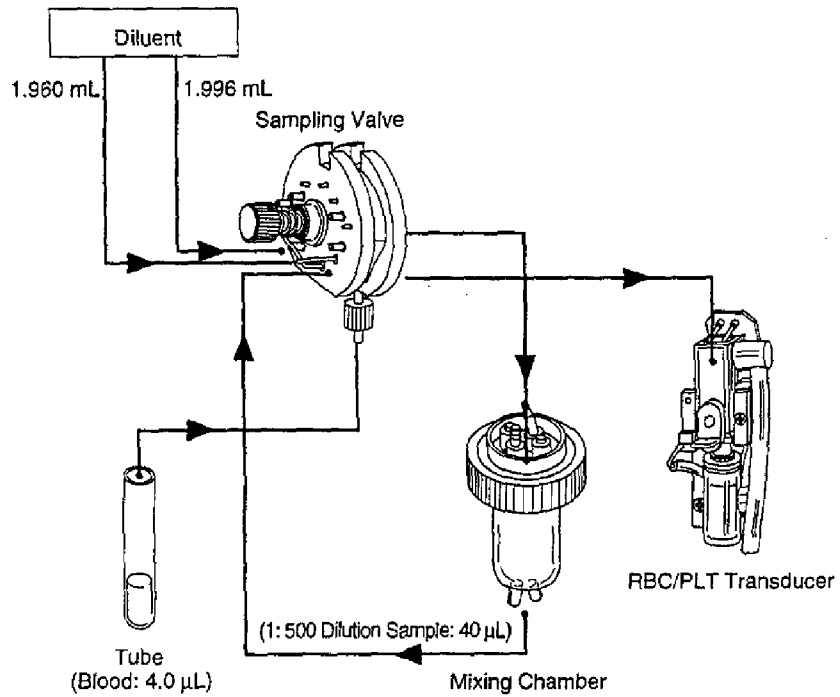

**Figure 2-4 RBC/PLT Analysis Flow (Whole Blood Mode)**

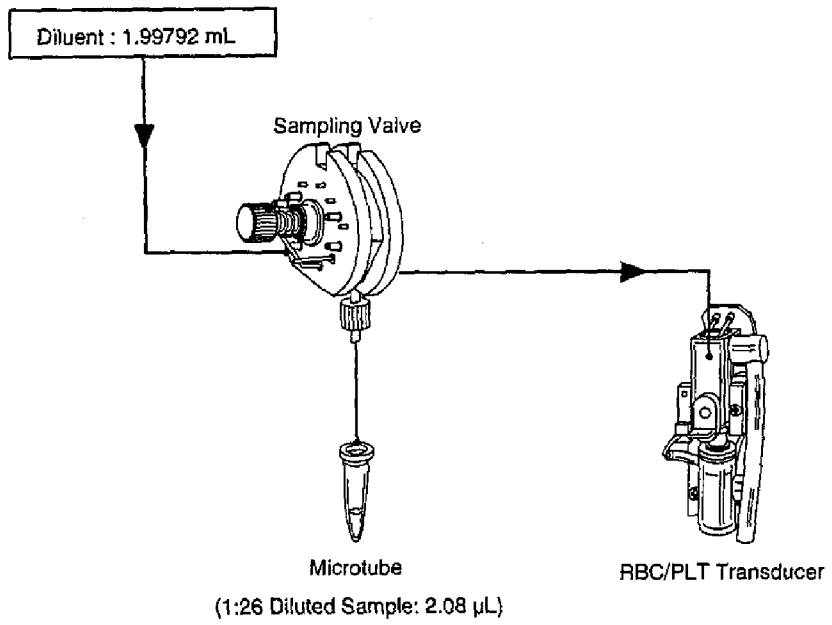

Figure 2-5 RBC/HPLTB Analysis Flow (Prep-diluted Mode)

## 2.3 SAMPLE FLOW IN SRV

### 2.3.1 Sample Path

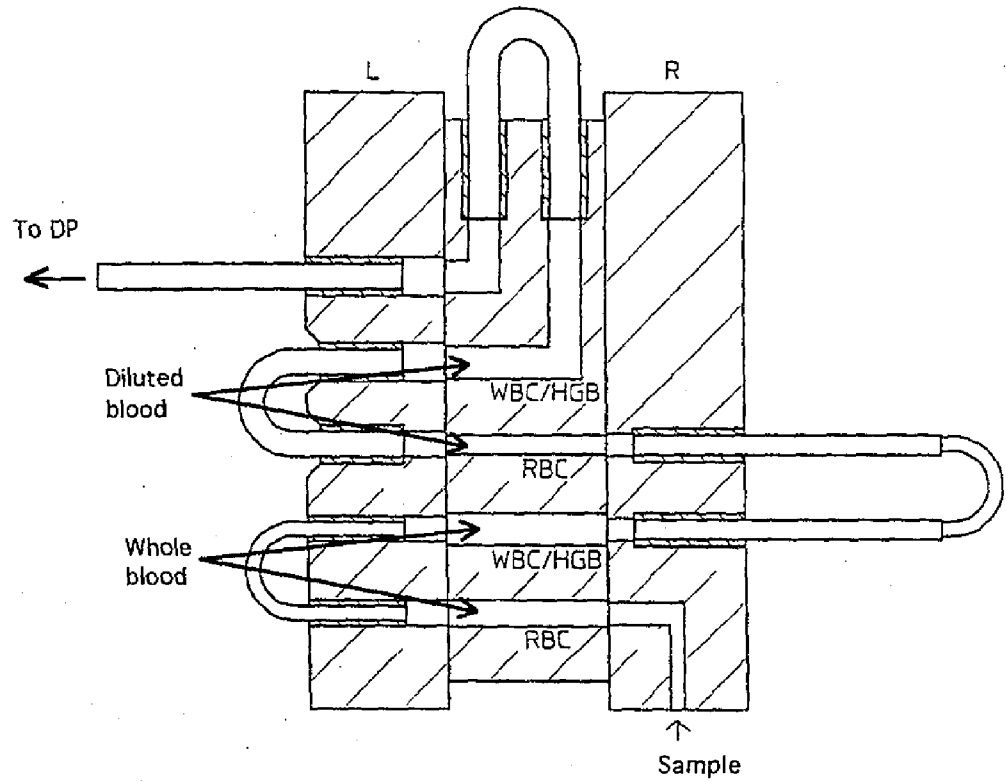

Figure 2-6 Sample Flow in SRV



## 2.4 SOLENOID VALVE LOCATION

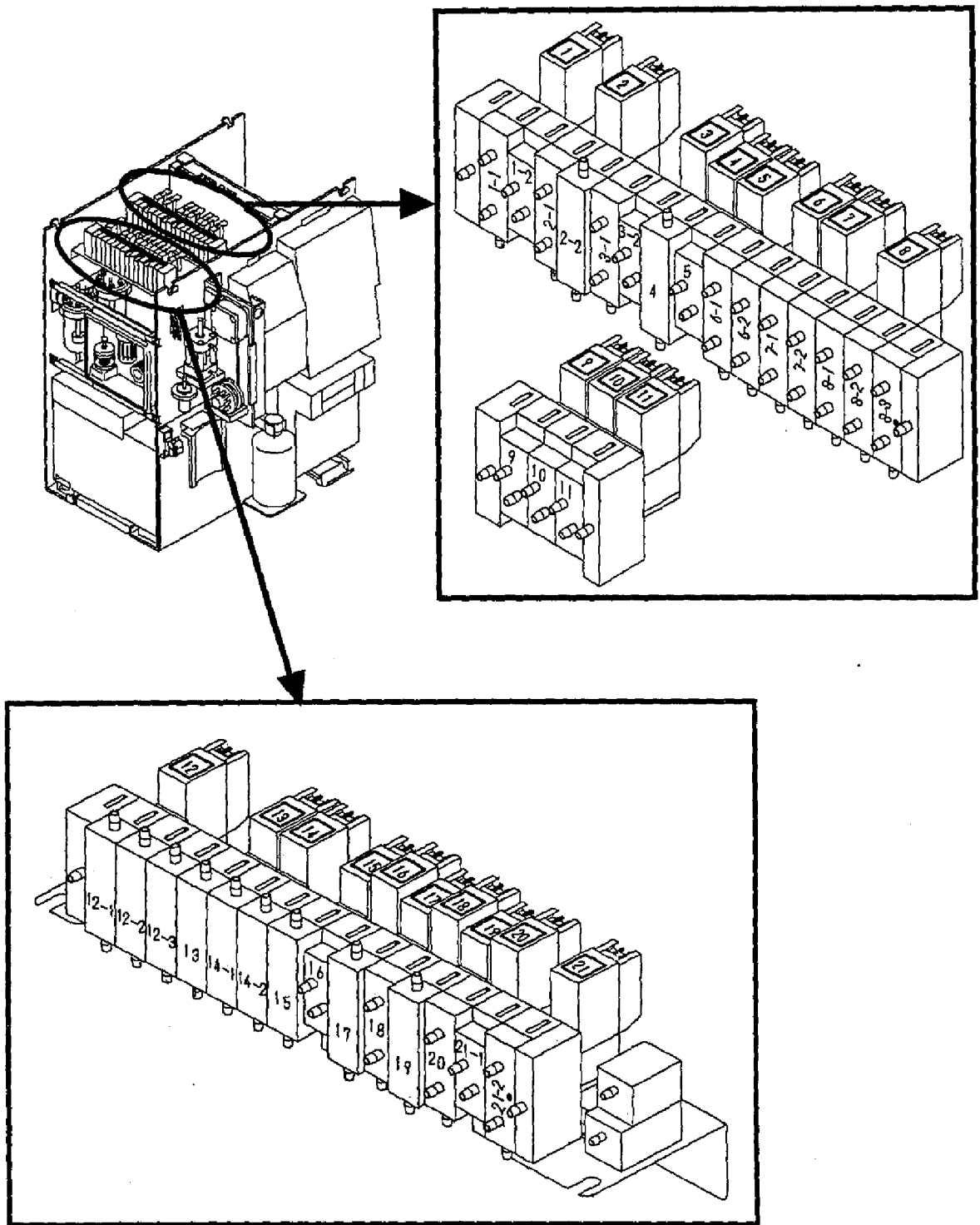

Figure 2-9 Valve Location

## 2.4.1 Valve Unit Tubing Connections

### (1) KX-21 Valve Unit A

MV No.	Function	MV No.	Function
1-1	Waste drain, switch pressure/vacuum	6-1	RBC diluent DP fill/dispense switch
1-2	Waste drain, drive Pinch Valve	6-2	RBC diluent DP drive
2-1	Diluent fill, switch pressure/vacuum	7-1	RBC diluent line switch
2-2	Diluent fill, connect diluent line	7-2	WBC/Hgb diluent line switch
3-1	Diluent chamber pressure cut	8-1	WBC/Hgb diluent DP/lyse DP drive
3-2	Rinse cup drain, drive Pinch Valve	8-2	WBC/Hgb diluent DP switch
4	STR-WH (lyse) dispense control	8-3	WBC/Hgb lyse DP switch
5	Fill Detector Block Master Valve Assy		

#### < Valve Unit A-1 >

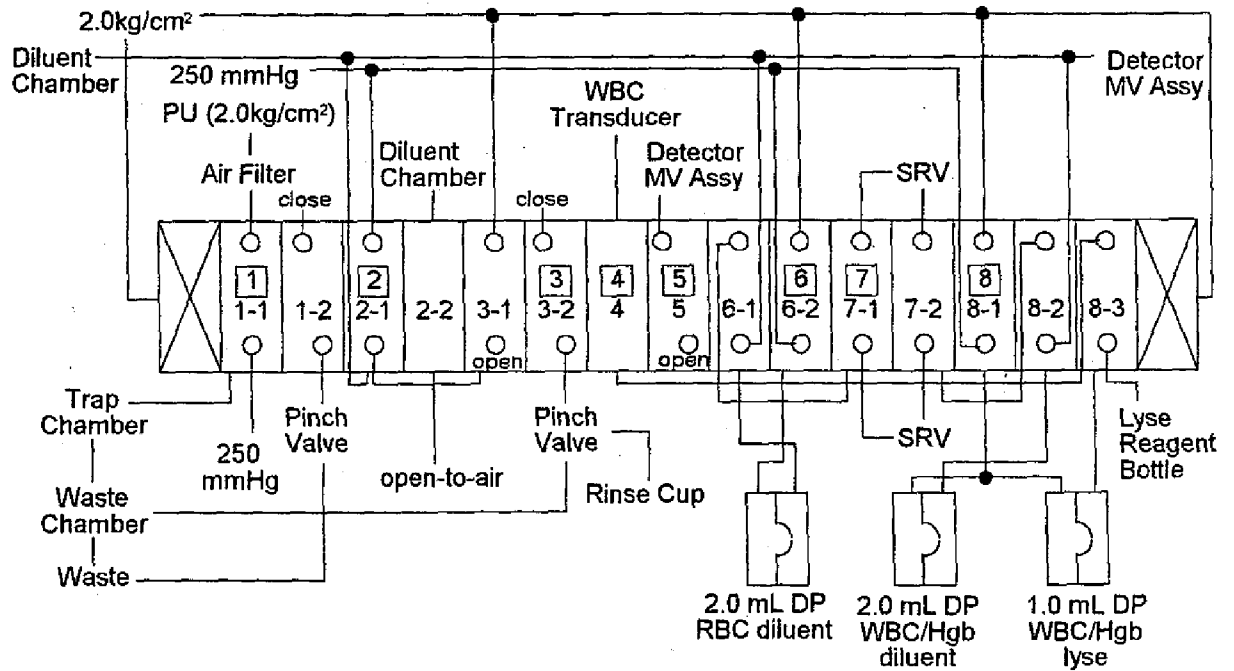

Figure 2-10: Valve Unit A-1 Tubing

#### < Valve Unit A-2 >

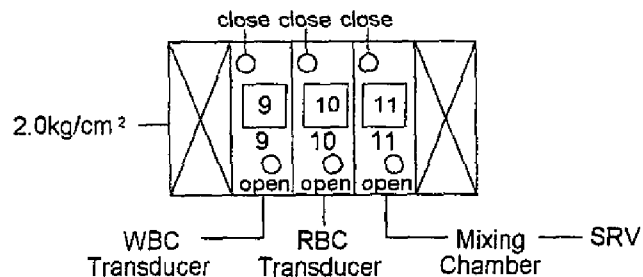

Figure 2-11: Valve Unit A-2 Tubing

(3) KX-21 Valve Unit B

MV No.	Function	MV No.	Function
12-1	Fill Rinse Cup	16	SRV rotation
12-2	SRV vacuum cut	17	RBC charging
12-3	SRV outer rinse	18	PD mode sample aspiration DP drive
13	Mixing Chamber drain	19	Supply rinse into sample aspiration line
14-1	RBC Transducer drain	20	WB mode sample aspiration DP drive
14-2	WBC Transducer drain	21-1	Air gap generation
15	Hgb Flow Cell drain	21-2	Detector DP drive for counting

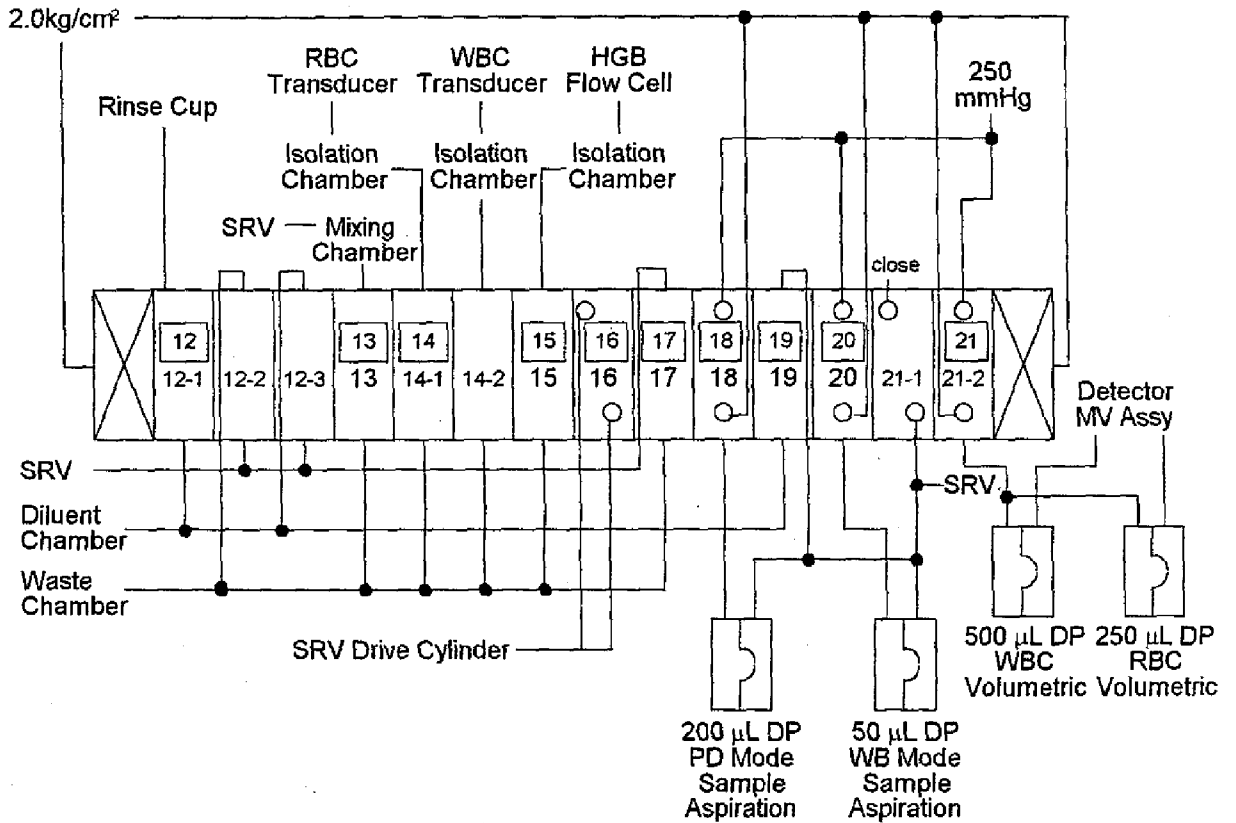
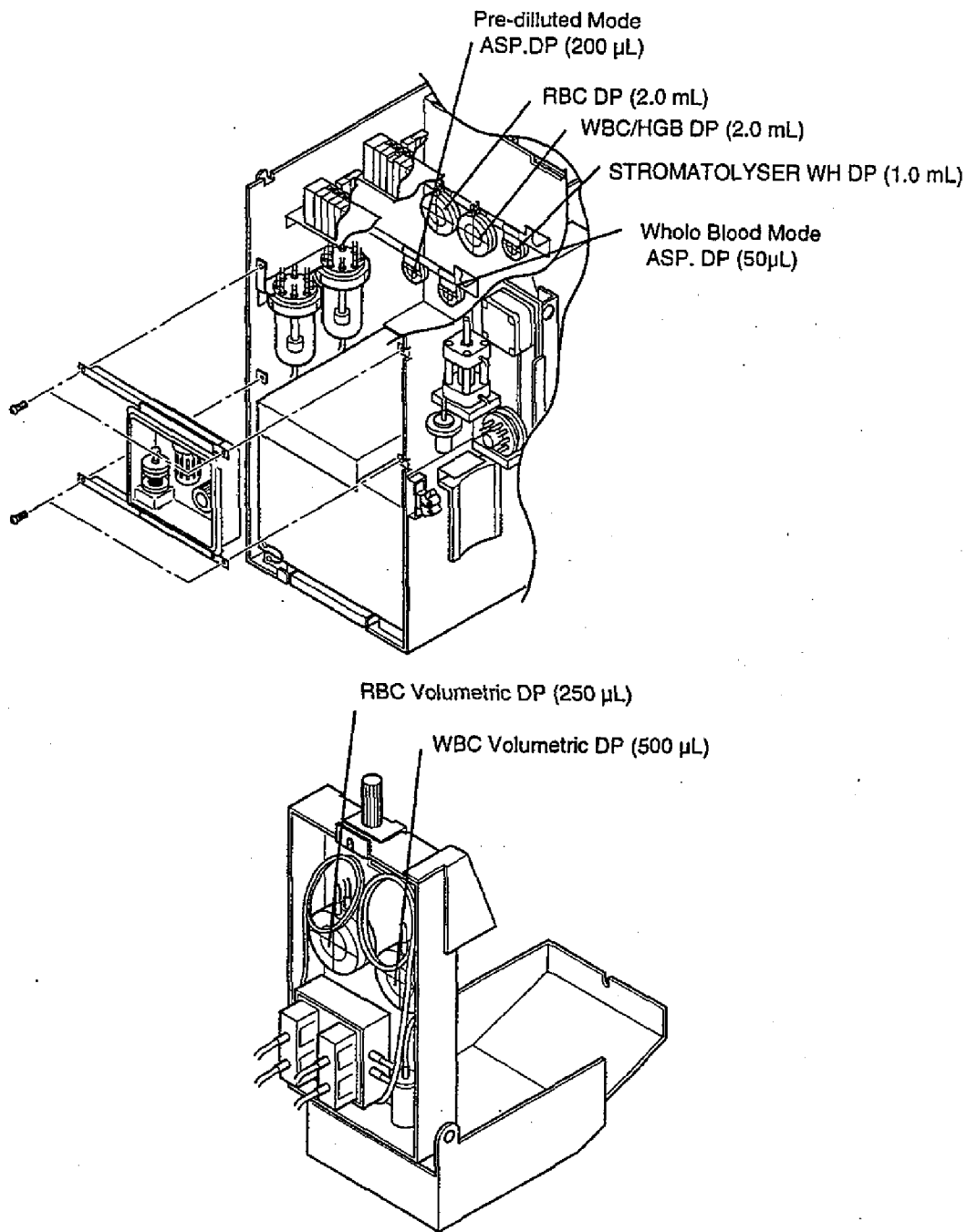

Figure 2-12: Valve Unit B Tubing



## 2.5 DIAPHRAGM PUMP LOCATION



**A** Figure 2-13: Diaphragm Pump Location

## 2.6 PNEUMATIC SYSTEM

Pressure is only monitored for 0.5 kg/cm<sup>2</sup>. (2.2 Kg/cm<sup>2</sup> is not monitored.)  
 Vacuum is only monitored for 250 mmHg. (Vacuum source is not monitored.)

### 2.6.1 Sample Aspiration System

Aspiration speed is adjusted to Whole Blood mode. Tube Teflon is inserted between Whole Blood DP and Diluted Blood DP for adjusting aspiration speed.

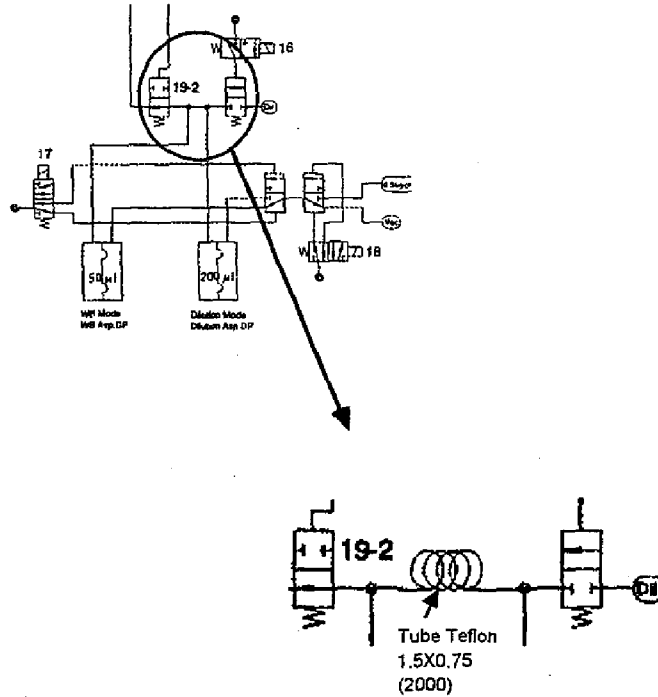

**A** Figure 2-14: Sample Aspiration System

### 2.6.2 Vacuum System

KX-21 has no tank for Vacuum system therefore Polyurethane tubing is inserted between bellows and pressure switch for stabilizing the vacuum.

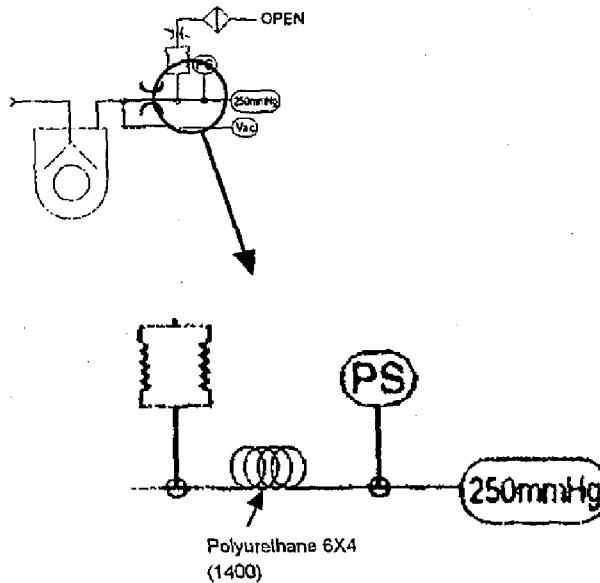

**A** Figure 2-15: Vacuum System

### 2.6.3 Pressure System

KX-21 has no tank for pressure system therefore Teflon tubing is inserted between compressor and 0.5 kg/cm<sup>2</sup> regulator for stabilizing the pressure.

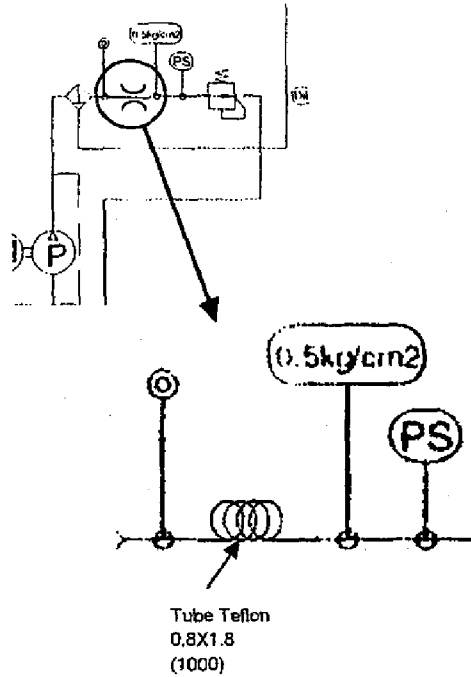

**A** Figure 2-16: Pressure System

### 2.7 WASTE CHAMBER TUBING

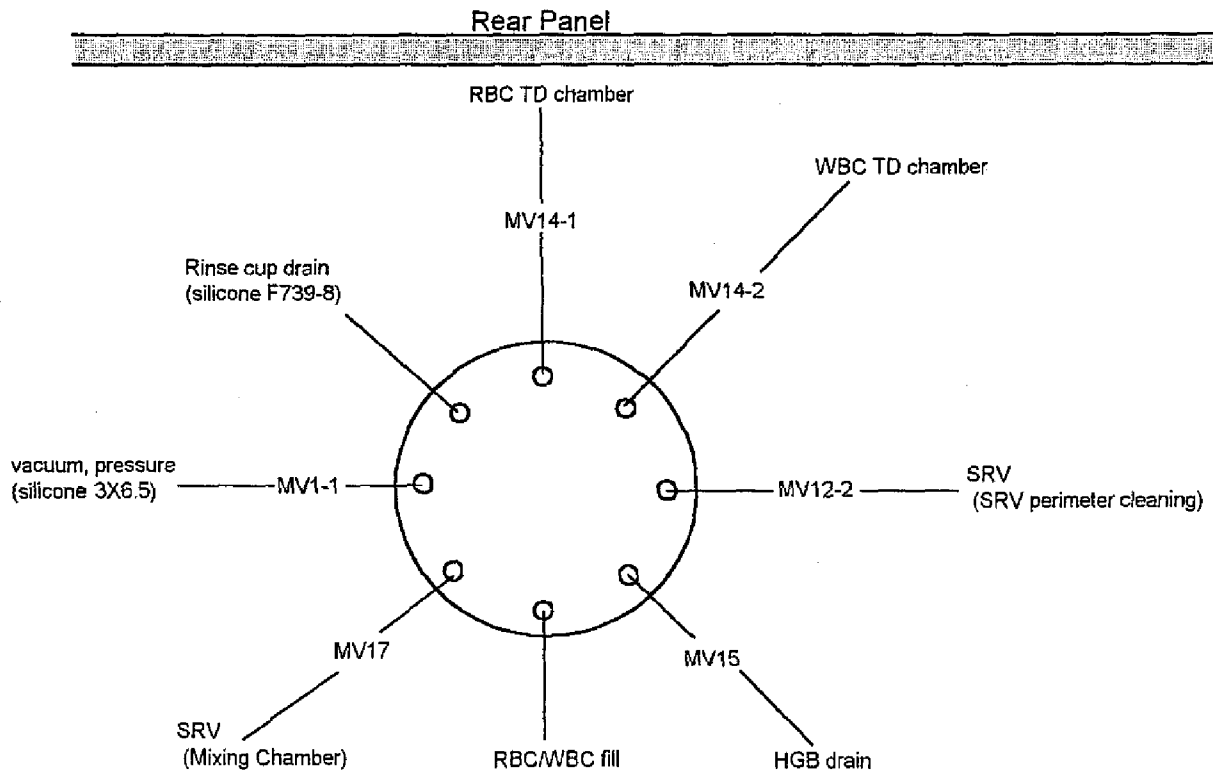

**A** Figure 2-17: Waste Chamber Tubing

## 2.8 RINSE CUP

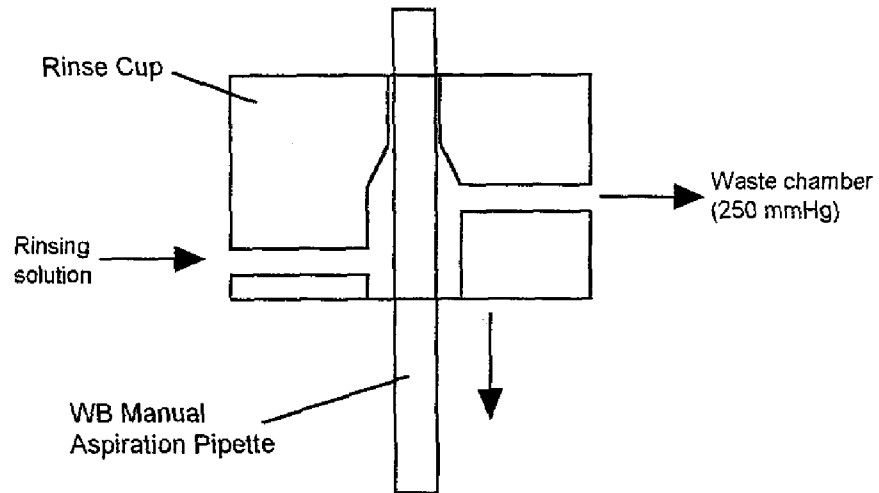

**A** Figure 2-18: Rinsing Pipette Exterior

Rinsing solution is injected while the rinse cup is going down and any blood adhering to the pipette exterior is aspirated into the waste chamber.

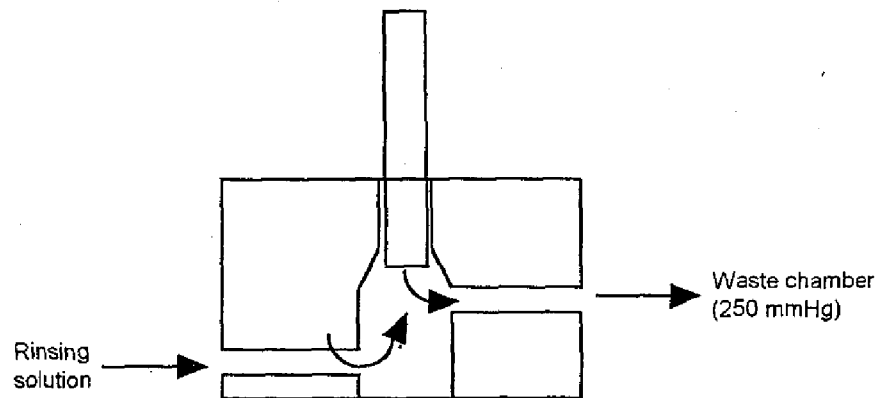

**A** Figure 2-19: Rinsing WB Line

To clean the whole blood line, rinsing solution (containing whole blood) is discharged from the pipette tip and aspirated into the waste chamber when the rinse cup reaches the lower end point. When the rinse cup goes up, rinsing solution will not be discharged nor aspirated into the pipette.

## 2.9 RBC DETECTOR UNIT

**A** Aperture size: 75  $\mu\text{m}$

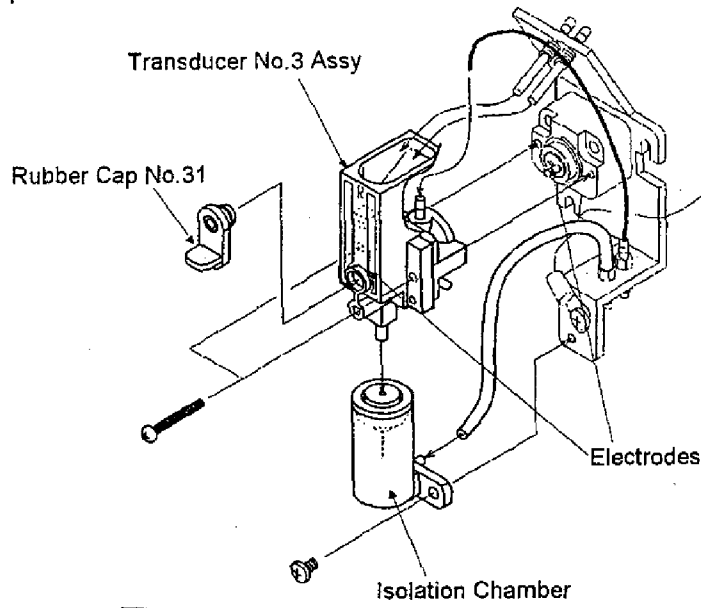

**A** Figure 2-20: RBC Detector Unit

## 2.10 WBC DETECTOR UNIT

**A** Aperture size: 100  $\mu\text{m}$

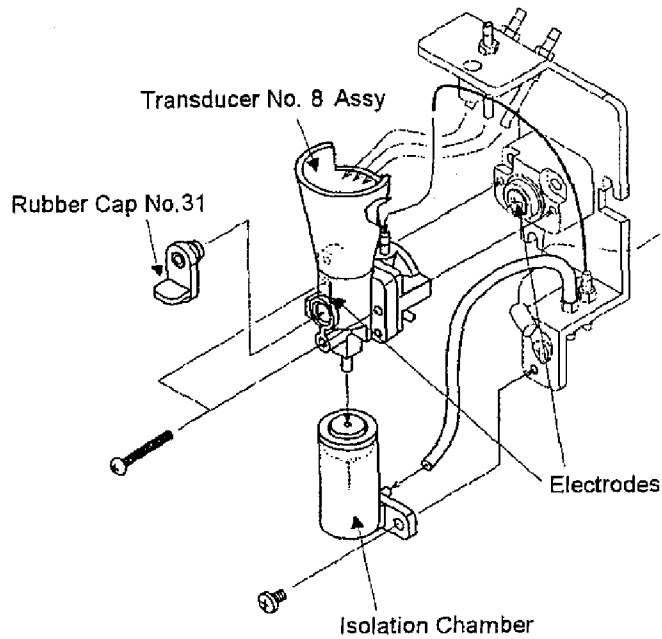

**A** Figure 2-21: WBC Detector Unit

## 2.11 SRV UNIT

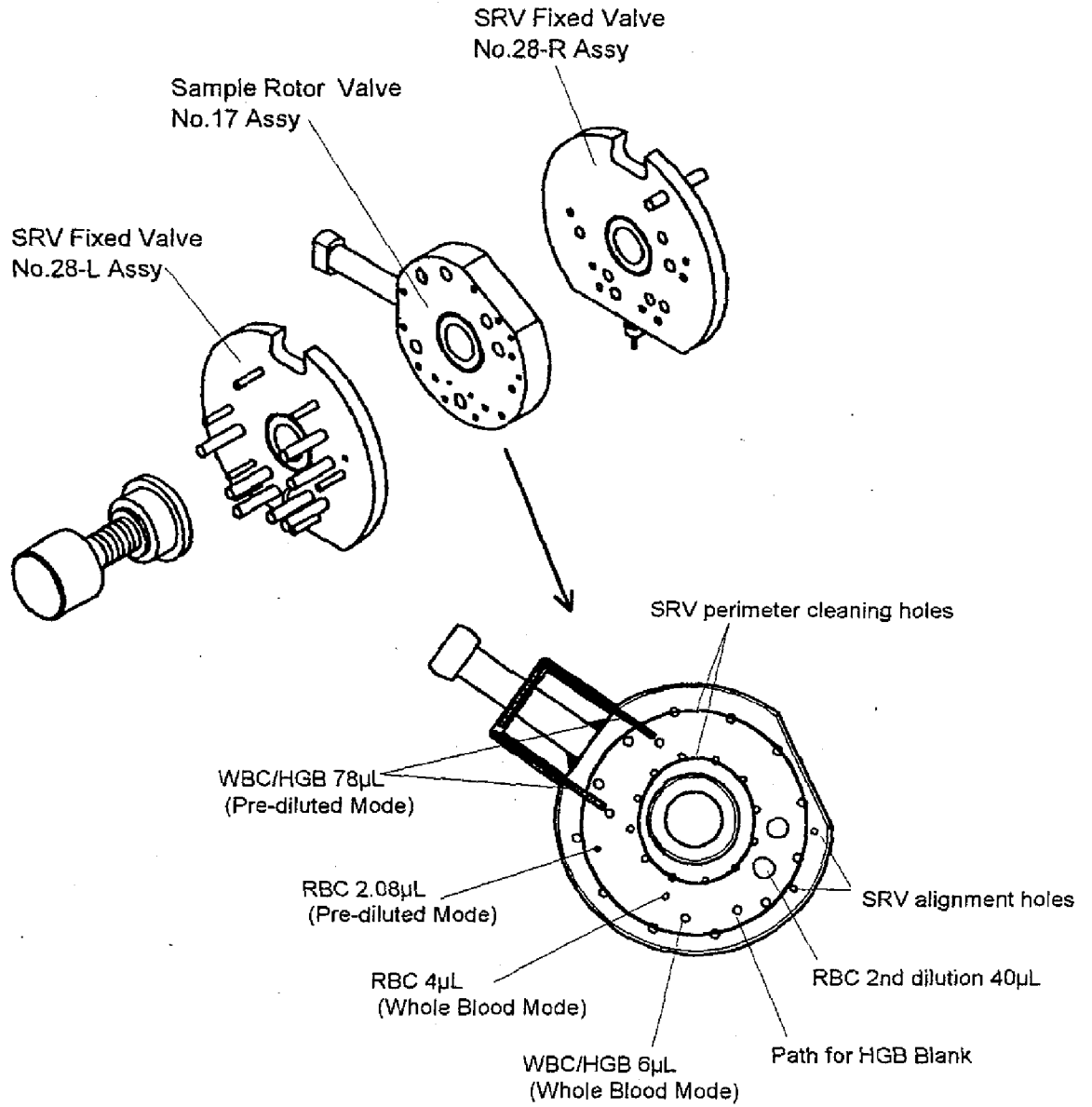

**A** Figure 2-22: SRV Unit

## 2.12 HYDRAULIC FLOW DESCRIPTION

Every operation on KX-21 is controlled by many solenoid valves inside instrument. The solenoid valve positions are shown in Hydraulic Diagram.

### 2.12.1 Whole Blood Mode

The following is the analysis flow in KX-21 Whole Blood Mode described in detail in accordance with Timing Charts in *Section 7*.

#### Sequence 1 (0.0 - 0.5 sec.)

(1) Sample Aspiration

Pressing Start Switch activates SV20, applies vacuum on DP (Diaphragm Pump), and then aspirates 50  $\mu\text{L}$  of sample blood through Aspiration Pipette. The aspirated sample passes through SRV (Sample Roter Valve) and waits for the volumetric dispensing afterward. SV20 is operating between 0.0 sec. and 19.5 sec. of Sequence 1.

(2) Air Bubble Removal in WBC/RBC TD (Transducer)

During Sequence 1 operation, between 0.0 sec. and 0.5 sec., SV5 is activated to apply vacuum on Waste Chamber and fill the diluent in WBC/RBC TD. This operation enables the air bubble remained around the aperture in the previous sequence to be removed.

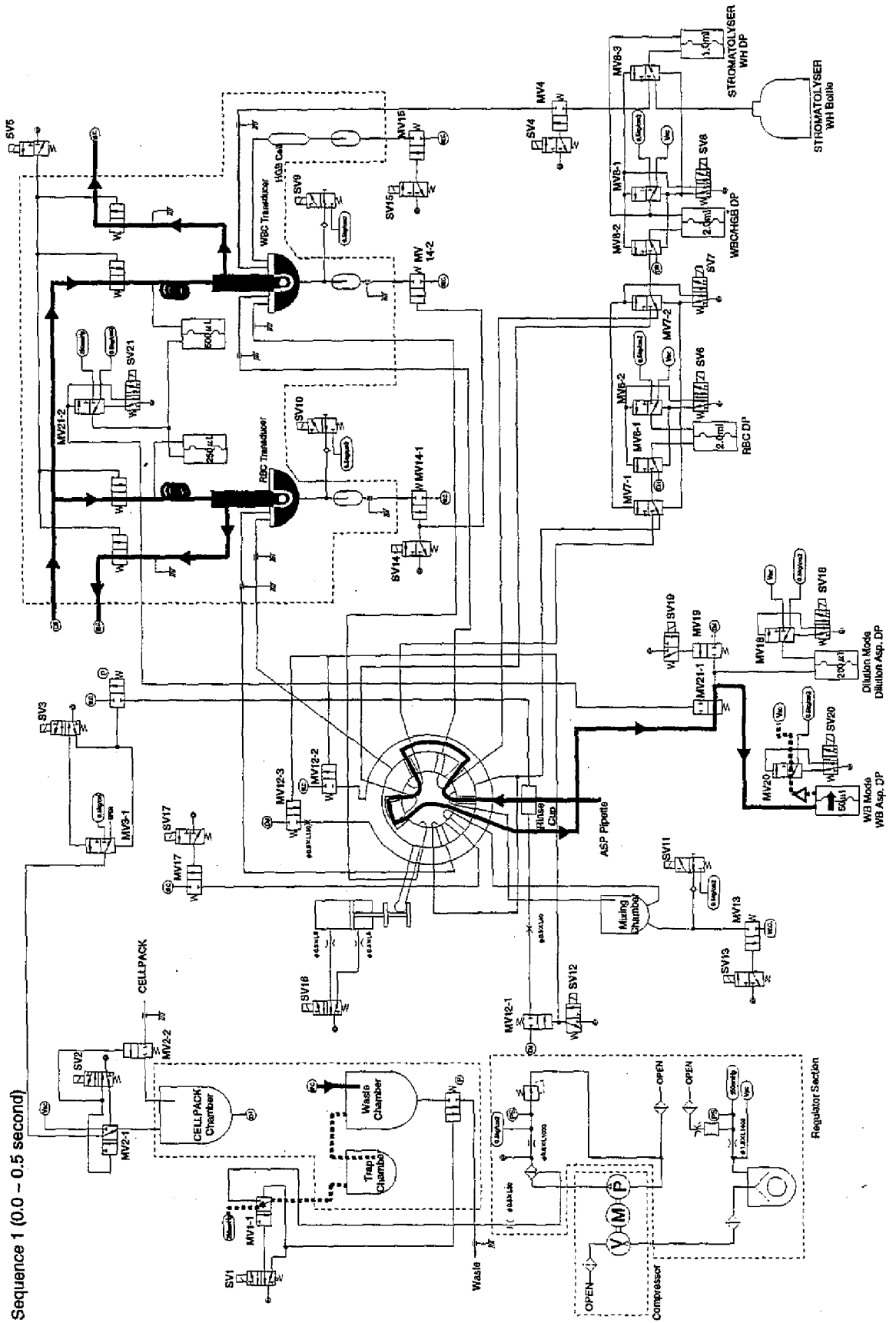

Sequence 1 (0.0 - 0.5 second)



**Sequence 1 (0.5 ~ 3.0 sec.)**

(1) Draining Mixing Chamber

SV13 is activated at the timing of 0.7 sec. to open MV13, which connects Mixing Chamber Draining line and Waste Chamber. As 250 mmHg vacuum is applied on Waste Chamber, the liquid in Mixing Chamber flows into Waste Chamber and is drained finally. This operation continues between 0.7 sec. and 3.0 sec.

In order to remove the remained liquid in Air Bubble Mixing line (between Non-Return Valve and T-Joint), SV11 operates 4 times (with 0.2 sec. interval) with high speed. Once SV is activated, it operates 3 times continuously to avoid Air Bubble Mixing line to be contaminated by the waste.

(2) Draining WBC/RBC TD Chamber

At the timing of 0.7 sec., SV14 is activated to open MV14-1 and MV14-2, which connects Draining line of WBC/RBC TD Chamber and Waste Chamber. As 250 mmHg vacuum is applied on Waste Chamber, the liquid in TD Chamber flows into Waste Chamber and is drained finally. This operation continues between 0.7 sec. and 3.0 sec.

In order to remove the remained liquid in Air Bubble Mixing line (between Non-Return Valve and T-Joint), SV11 operates 4 times (with 0.2 sec. interval) with high speed. Once SV is activated, it operates 3 times continuously to avoid Air Bubble Mixing line to be contaminated by the waste. SV9 operates twice continuously between 1.2 sec. and 1.6 sec. to avoid Air Bubble Mixing line to be contaminated by the waste.

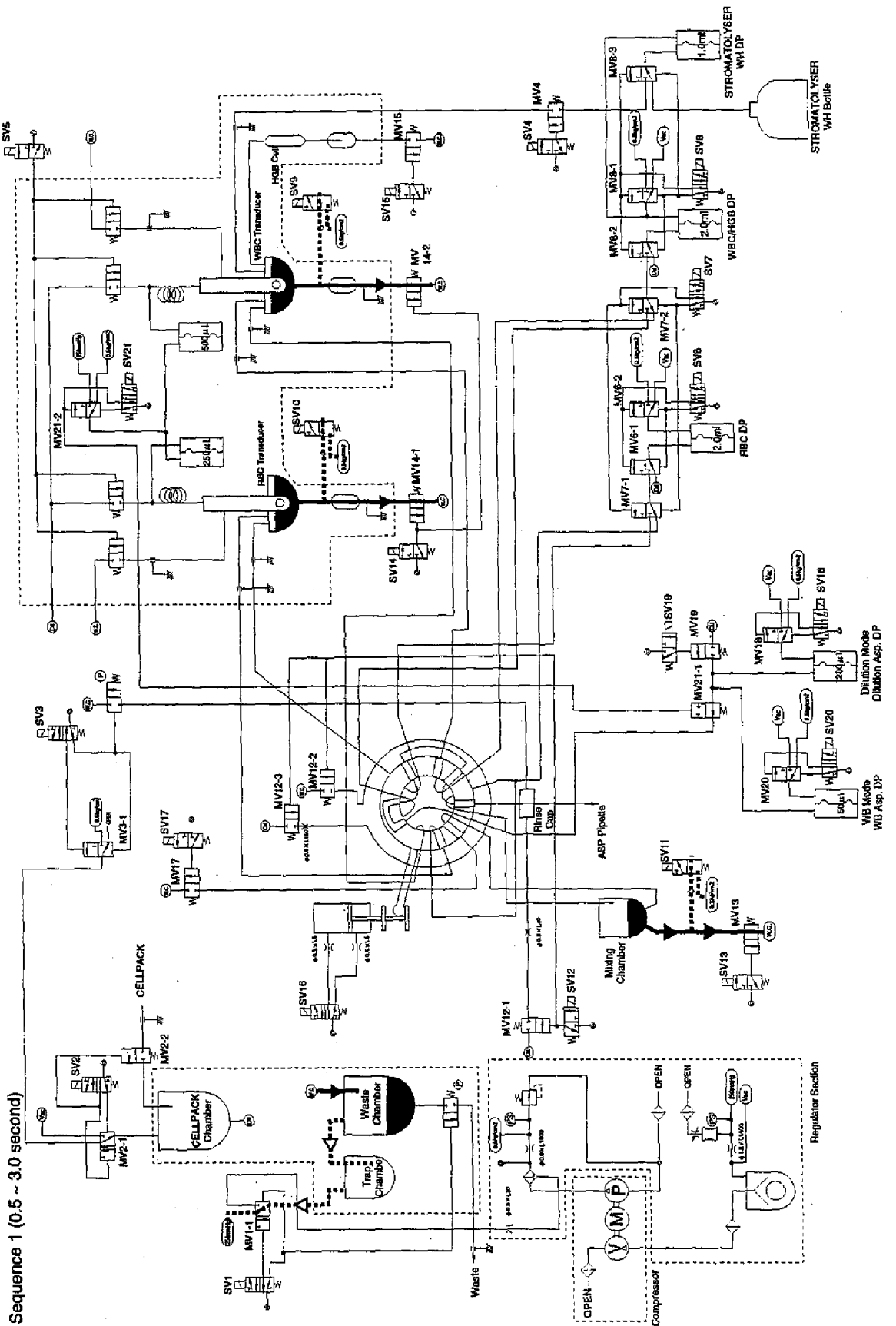

**Sequence 1 (3.0 ~ 5.0 sec.)**

(1) Dispensing Diluent into WBC TD Chamber

At the timing of 3.0 sec., SV8 is activated to make WBC/HGB DP dispense 2.0 mL of diluent into WBC TD Chamber through SRV.

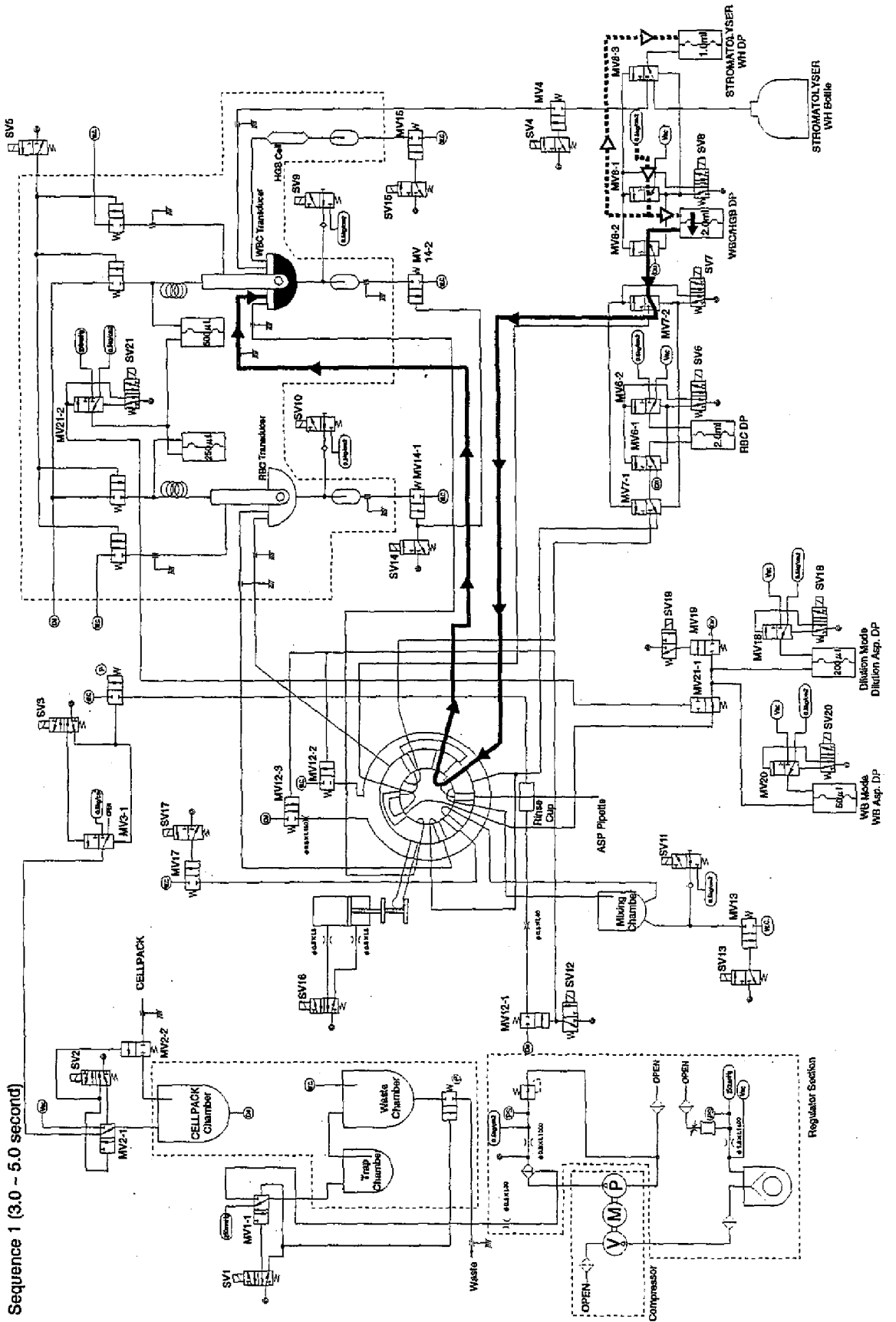

**Sequence 2 (5.0 ~ 6.2 sec.)**

(1) Dispensing Sample (SRV Rotation)

SV16 is activated at the timing of 5.0 sec. to drive the piston controlling the SRV rotation. SRV rotates in CCW direction (seeing from the left side of the instrument). This rotation enables 4  $\mu$ L of sample to be dispensed for RBC parameter analysis, and 6  $\mu$ L for WBC/HGB. The dispensed sample blood remains each Dilution line. SRV keeps this position until the timing of 14.5 sec.

(2) Aspirating Diluent into HGB Analysis Line for Blank Measurement

SV15 operates between 5.5 sec. and 6.1 sec. to open MV15. By applying the vacuum (250 mmHg) on Waste Chamber, the diluent in WBC TD Chamber is aspirated into HGB Flow Cell, prepared for the blank measurement afterward.

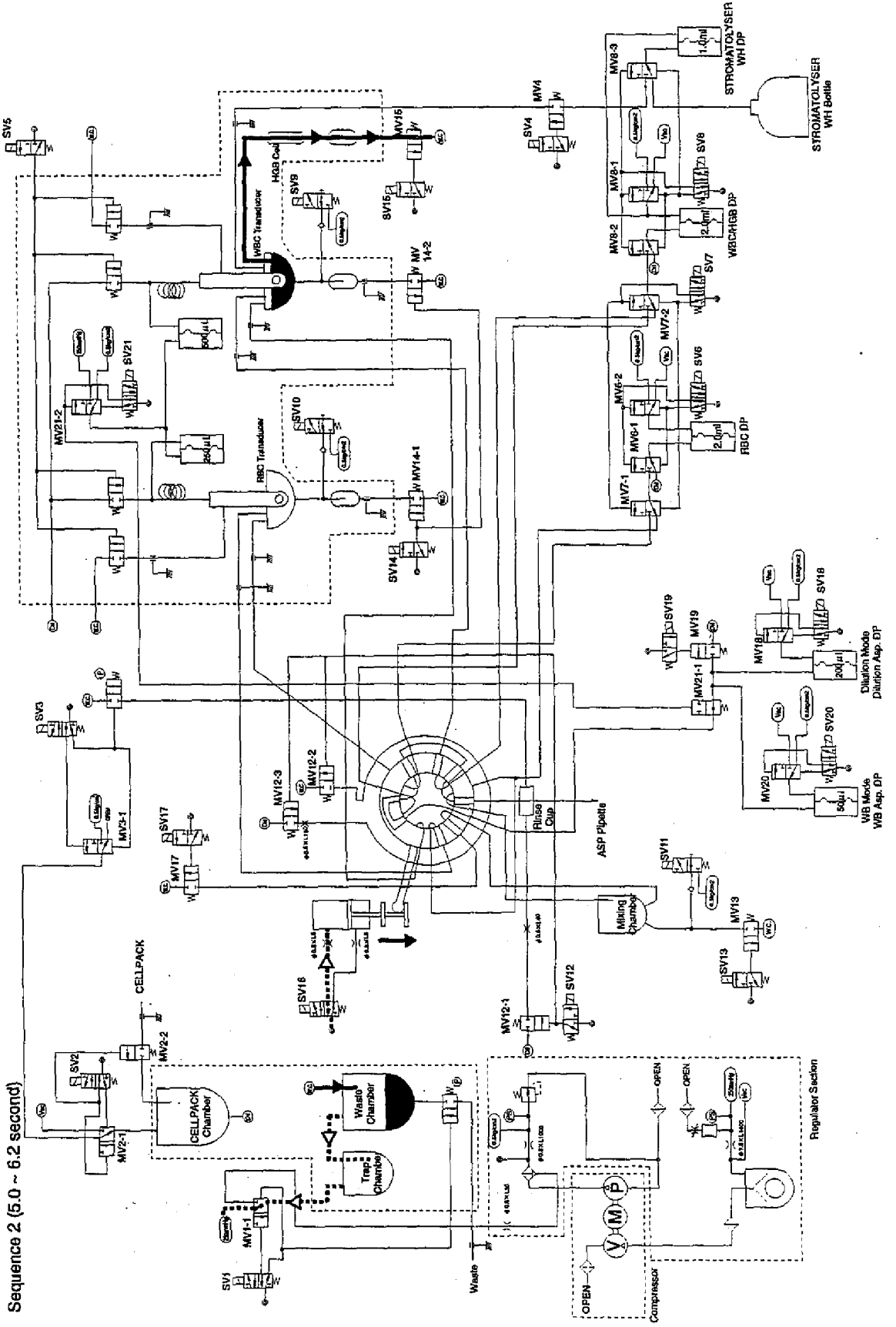

**Sequence 3 (6.2 ~ 9.5 sec.)**

(1) RBC/PLT First Diluting

SV6 is activated at the timing of 6.2 sec. to disconnect the Diluent line from MV6-1 and connect MV6-1 and RBC/PLT First Diluting line. RBC DP makes 2 mL of diluent with 4  $\mu$ L sample dispensed on SRV flow into Mixing Chamber. At the same time, SV11 performs the operation of 0.2 sec. with 0.2 sec. intervals four times continuously to mix the diluted sample with air bubbles in Mixing Chamber. The dilution ratio of the sample in Mixing Chamber is 1 : 500.

(2) Rinsing SRV and Sample Aspiration Pipette

SV3 operates between 7.0 sec. and 9.3 sec. to switch the air release of MV3-1 to 0.5 kg/m<sup>2</sup> pressure, which applies pressure on CELLPACK Chamber. SV12 operates between 8.0 sec. and 8.6 sec. to open MV12-2 and MV12-3 at the same time. CELLPACK flows through the peripheral part of SRV to rinse it by the simultaneous application of the pressure on CELLPACK Chamber and the vacuum on Waste Chamber. Opening MV12-1 and Pinch Valve controlled by SV3 enables CELLPACK to pass through Rinse Cup and be aspirated into Waste Chamber. At the same time, Rinse Cup goes up and down along Aspiration Pipette by Stepper Motor, which enables Aspiration Pipette to be rinsed.

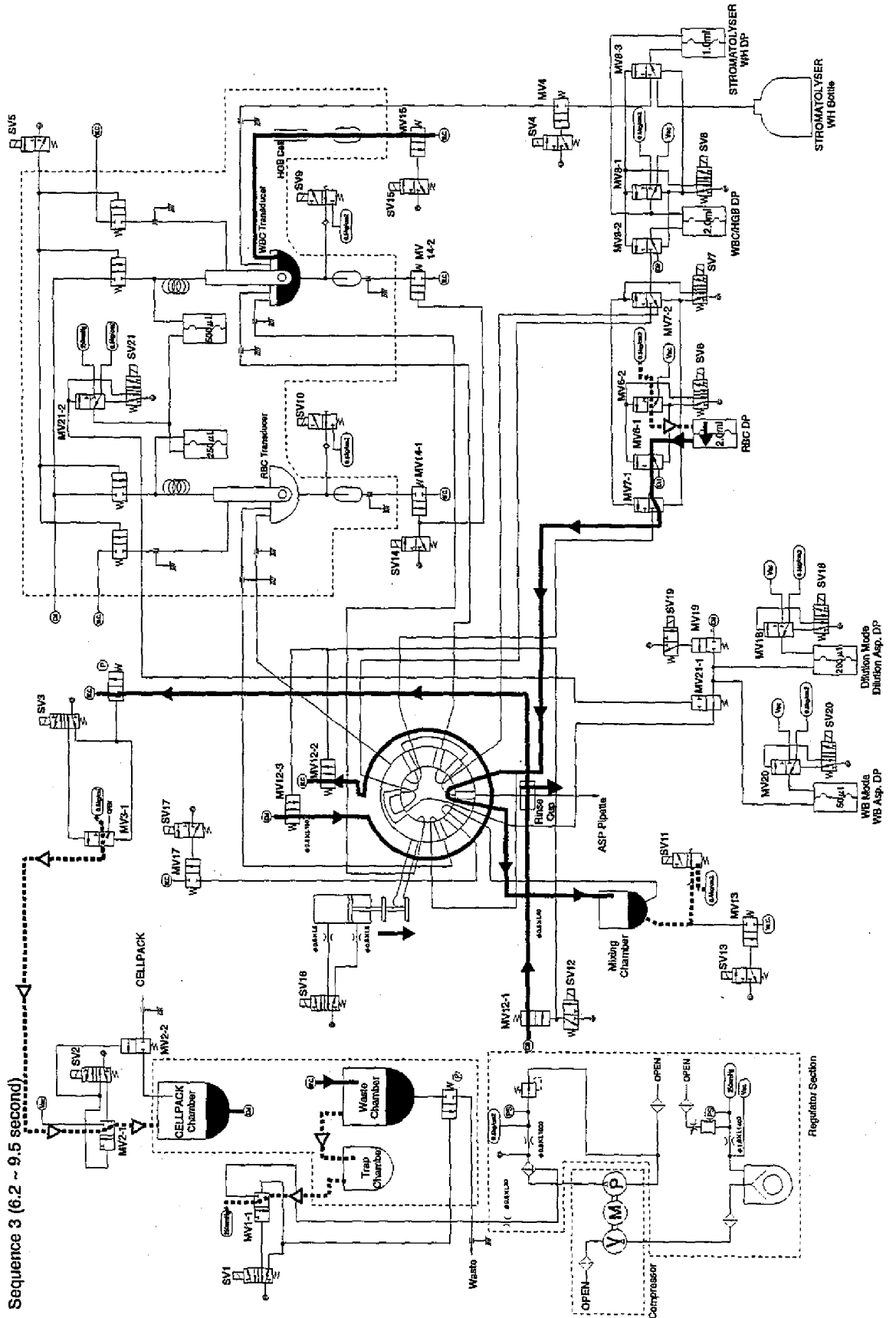



**Sequence 4 (9.5 - 10.3 sec.)**

(1) Sample Aspiration for RBC Second Diluting

SV17 is activated between 9.5 sec. and 10.3 sec. to open MV17. The first diluted sample in Mixing Chamber passes through SRV by the vacuum (250 mmHg) in Waste Chamber to prepare for the RBC second diluting.

(2) Reagent Aspiration by DP

At the timing of 9.3 sec., SV6 and SV8 close, and RBC DP and WBC/HGB DP aspirate 2.0 mL each of CELLPACK, and STROMATOLYSER WH DP aspirates 1.0 mL of Lyse Reagent respectively to prepare for the next sequence.

Sequence 4 (9.5 ~ 10.3 second)

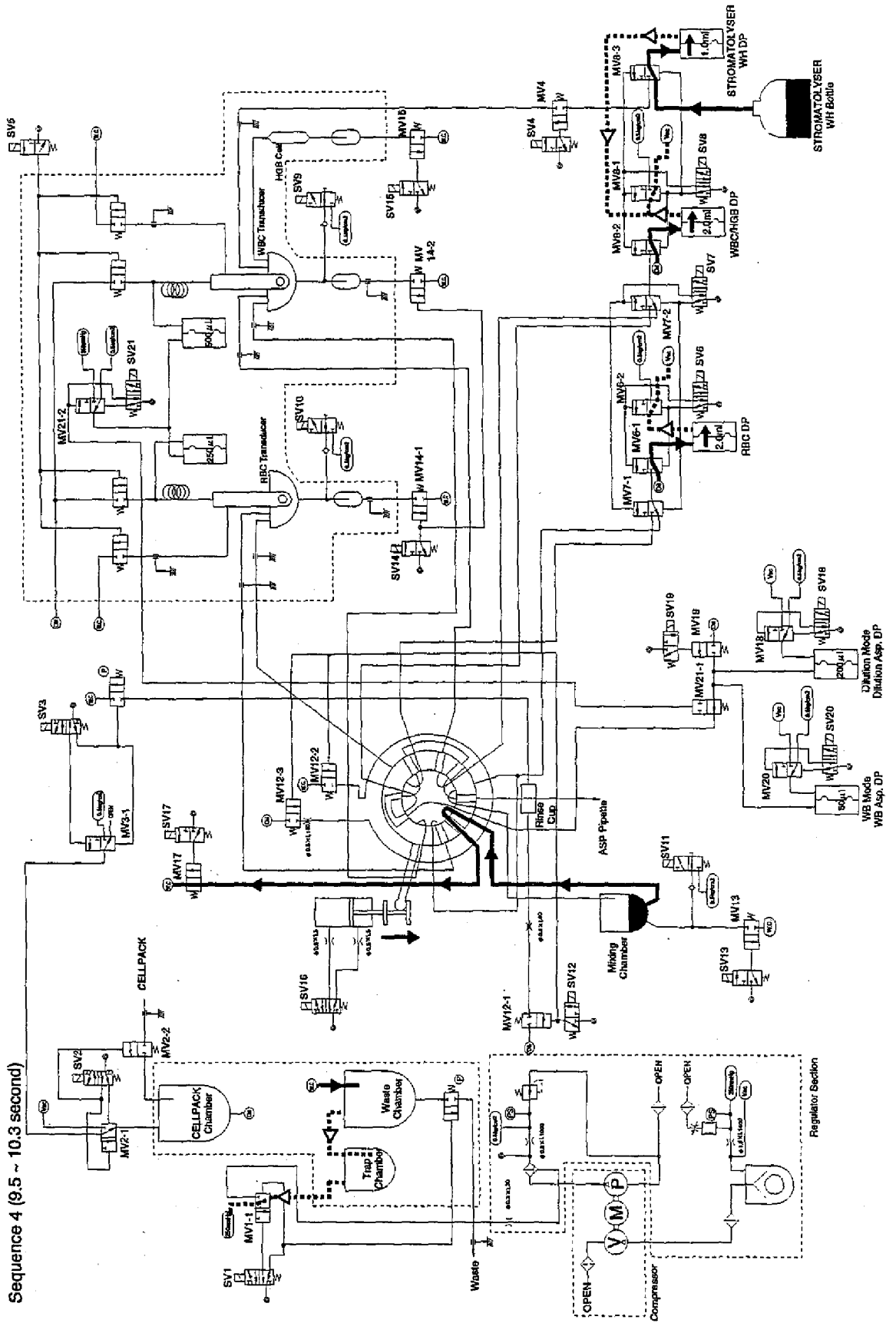

**Sequence 4 (10.3 ~ 12.5 sec.)**

(1) Aspirating CELLPACK into CELLPACK Chamber

SV2 is activated between 10.3 sec. and 11.5 sec. to connect MV2-1 and VACUUM line, which enables CELLPACK in the reagent cubitainer outside Main Unit to be aspirated into CELLPACK Chamber.

(2) Draining RBC/WBC TD Chamber

SV14 is activated between 10.5 sec. and 12.5 sec. to connect MV14-1 and MV14-2 to Waste Chamber. As the vacuum (250 mmHg) is applied on Waste Chamber, the liquid in RBC/WBC TD Chamber flows into Waste Chamber to empty the TD Chamber. To remove the remained liquid in Air Bubble Mixing line (between Non-Return Valve and T-Joint), SV9 and SV10 perform the open/close operation twice continuously with an interval of 0.2 sec.

(3) Draining RBC First Diluted Sample in Mixing Chamber

SV13 is activated between 10.7 sec. and 12.5 sec. to connect MV13 and Waste Chamber. As the vacuum (250 mmHg) is applied on Waste Chamber, the RBC first diluted sample in Mixing Chamber flows into Waste Chamber to empty Mixing Chamber. To remove the remained liquid in Air Bubble Mixing line (between Non-Return Valve and T-Joint), SV11 operated 3 times with high speed. The first operation is performed between 10.5 sec. and 10.7 sec. and the second and third operations are between 11.7 sec. and 12.3 sec. respectively with an interval of 0.2 sec.

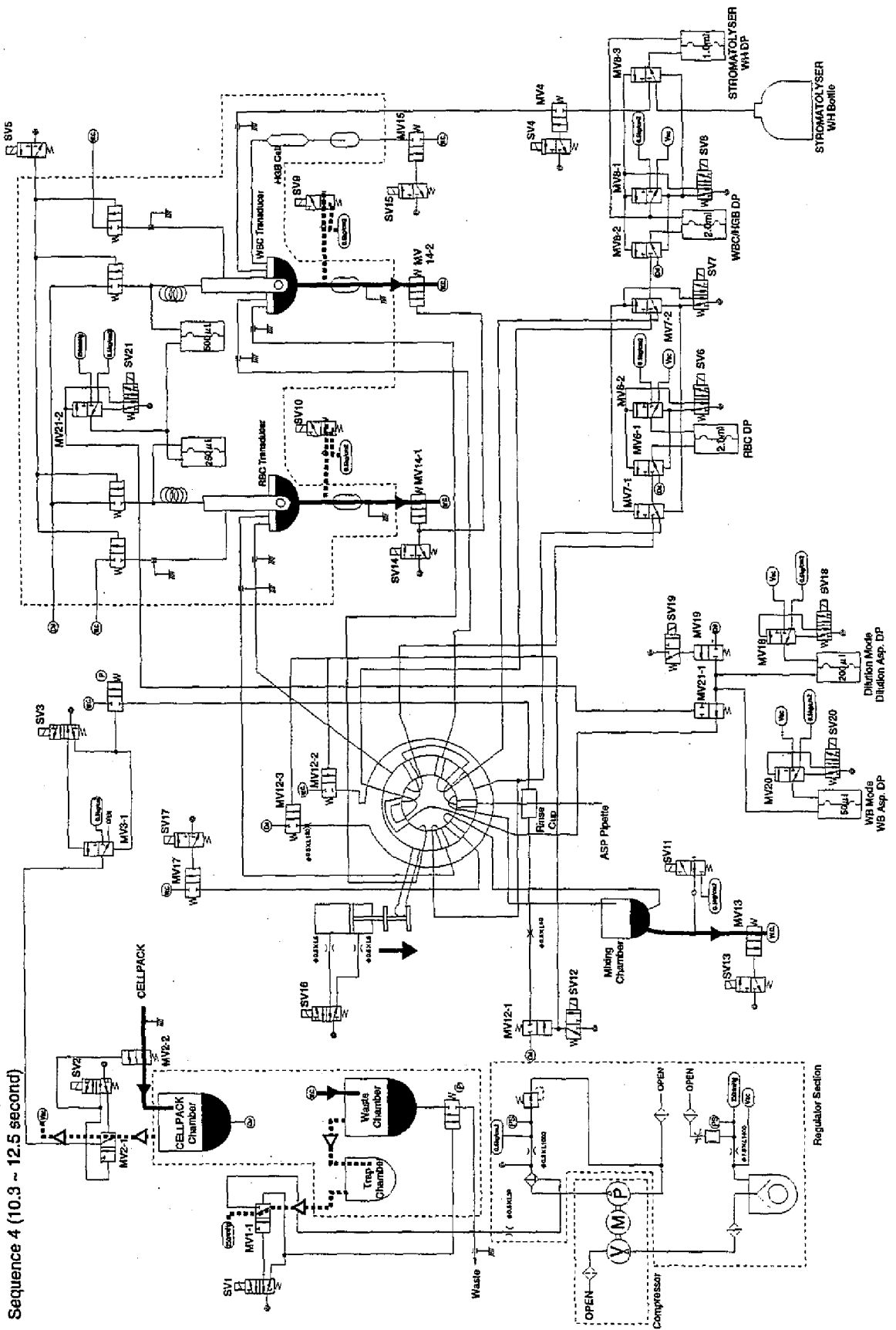

Sequence 4 (10.3 ~ 12.5 second)

#### Sequence 4 (12.5 ~ 14.5 sec.)

- (1) Draining Waste Chamber  
SV1 is activated between 12.7 sec. and 14.0 sec. to release Pinch Valve controlling the Waste Chamber drain. At the same time, MV1-1 and PRESSURE line are connected to apply pressure on Waste Chamber to drain the waste outside instrument via the waste tube.
- (2) Aspirating CELLPACK into CELLPACK Chamber  
SV2 is activated between 12.5 sec. and 14.0 sec. to connect MV2-1 and VACUUM line, which enables CELLPACK in the reagent cubitainer outside Main Unit to be aspirated into CELLPACK Chamber.
- (3) Rinsing Inside Mixing Chamber  
SV6 is activated at the timing of 12.5 sec. to make RBC DP dispense 2.0 mL of CELLPACK into Mixing Chamber and rinse RBC First Diluting line and Mixing Chamber. The other purpose of this operation is to avoid the precipitated crystals, etc. in the remained liquid after the previous rinsing to affect on the analysis result.
- (4) WBC Diluting/Lysing  
SV8 is activated at the timing of 12.5 sec. to make WBC/HGB DP dispense 2.0 mL of CELLPACK with 6  $\mu$ L of sample blood cut away by SRV via WBC Dilution line into WBC TD Chamber. At the same time, SV4 is activated to drive STROMATOLYSER-WH DP to dispense 1.0 mL of Lyse reagent into WBC TD Chamber.  
After the diluted sample and Lyse reagent are dispensed into WBC TD Chamber, SV9 operates 10 times with an interval of 0.2 sec. from the timing of 13.5 sec. to mix the sample with air bubble in TD Chamber. This makes the sample in WBC TD Chamber diluted by 500 times.

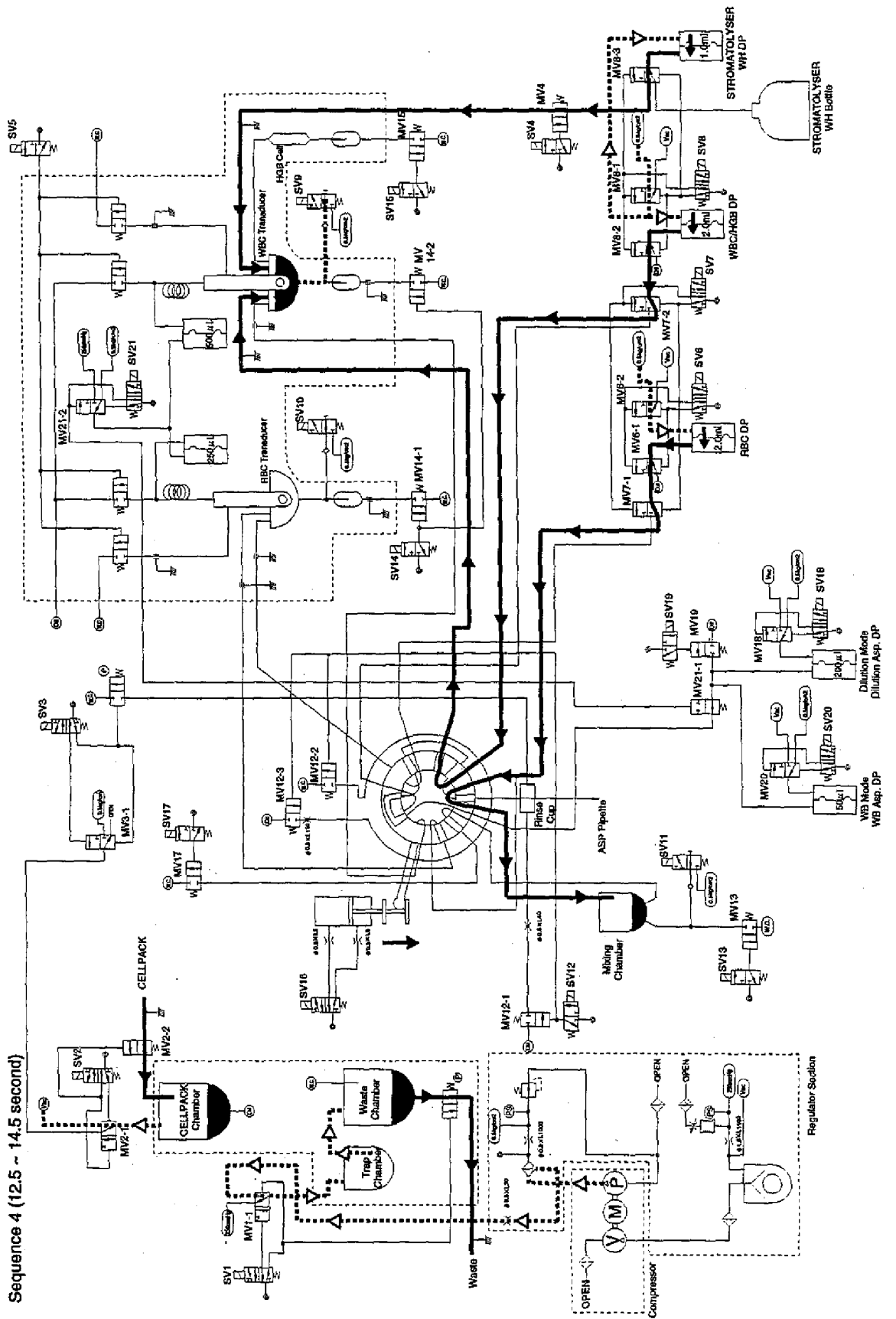

**Sequence 5 (14.5 ~ 15.7 sec.)**

(1) SRV Rotation

SV16 is deactivated at the timing of 14.5 sec. to make SRV rotate in the CW direction and return to the home position.

(2) Aspirating Diluent by RBC DP

SV6 is deactivated at the timing of 14.0 sec. to enable RBC DP to aspirate 2.0 mL of CELLPACK.

Sequence 5 (14.5 ~ 15.7 second)

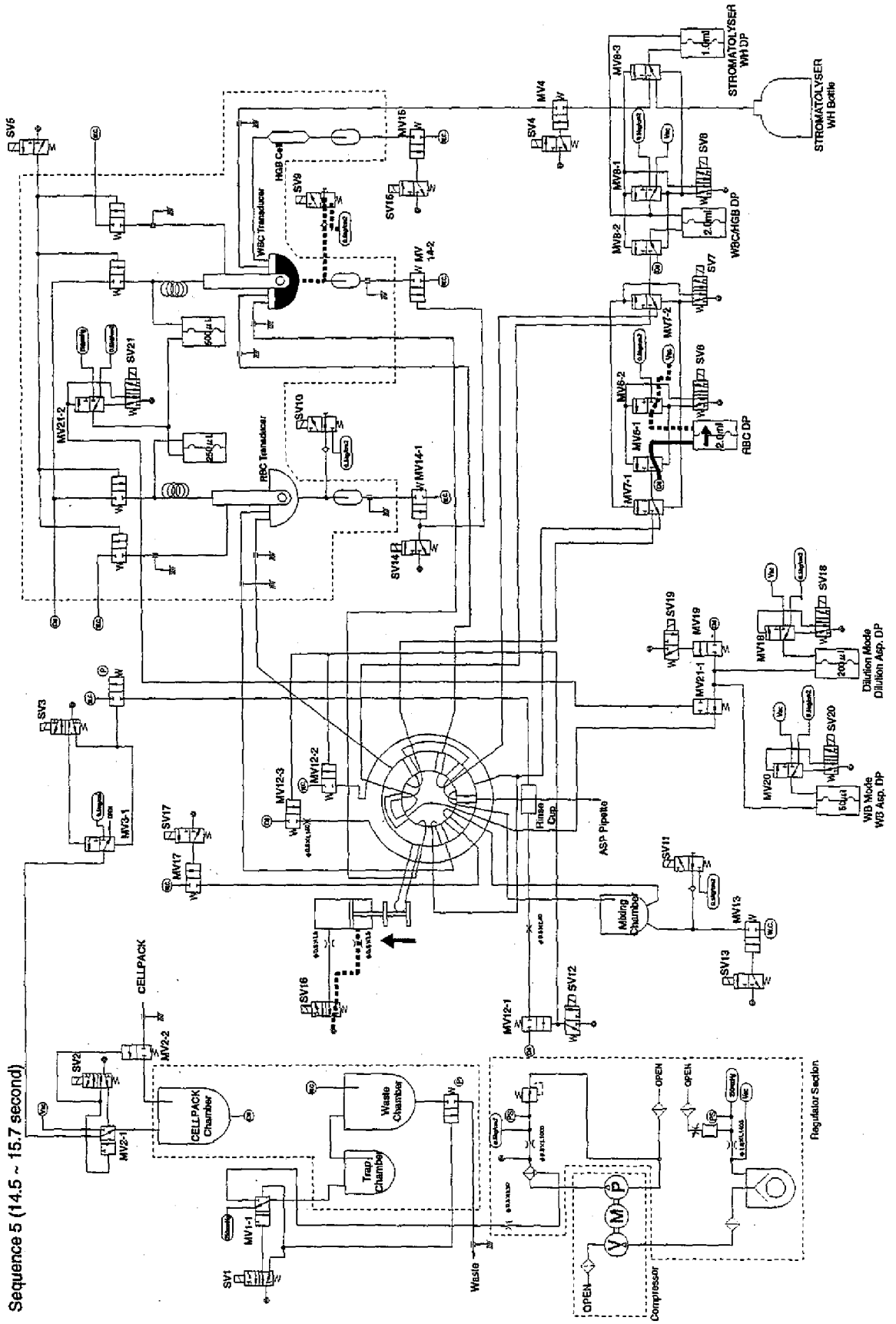



**Sequence 6 (15.7 ~ 21.0 sec.)**

(1) Rinsing Whole Blood Aspiration Line and Outside Aspiration Pipette

At the timing of 15.7 sec., the rinsing of the outside of Aspiration Pipette and the inside of WB Aspiration line starts at the same time. SV3 is activated to switch MV3-1 to the pressure of 0.5 kg/cm<sup>2</sup> to apply pressure on CELLPACK Chamber. Also, the pinch valve controlled by SV3 is released to connect WB Aspiration line and Waste Chamber. SV12 is activated to connect MV12-1 to CELLPACK Chamber. The diluent passes through Rinse Cup, rinses outside Aspiration Pipette and is aspirated finally into Waste Chamber by the vacuum application.

SV19 is activated between 16.0 sec. and 20.6 sec. to connect MV19 to CELLPACK Chamber. As the pressure is applied on CELLPACK Chamber, the diluent passes through WB Aspiration line and SRV, and is drained from the end of Aspiration Pipette. The vacuum on Waste Chamber makes the drained diluent passes through Rinse Cup and flow into Waste Chamber.

(2) Rinsing SRV

SV12 is activated between 15.7 sec. and 20.5 sec. to open MV12-2 and MV12-3 at the same time. CELLPACK flows through the peripheral part of SRV to rinse it by the simultaneous application of the pressure in CELLPACK Chamber and the vacuum in Waste Chamber (250 mmHg).

(3) RBC Second Diluting

SV6 is activated at the timing of 15.7 sec. to make RBC DP dispense 2.0 mL of CELLPACK and dispense with 40 µL of 1 : 500 RBC diluted sample into RBC TD through RBC Second Dilution line. This makes the sample in RBC TD Chamber diluted by 25000 times. SV10 performs the open/close operation eight times with an interval of 0.2 sec. between 17.0 sec. and 19.6 sec. to mix the sample with air bubble in RBC TD Chamber.

(4) HGB Blank Convert

Blank Convert is performed between 10.0 sec. and 10.5 sec. for the diluent in HGB Flow Cell. The operation is performed 5 times with an interval of 0.1 sec. (On blank measurement, the diluent in the HGB Flow Cell does not flow.)

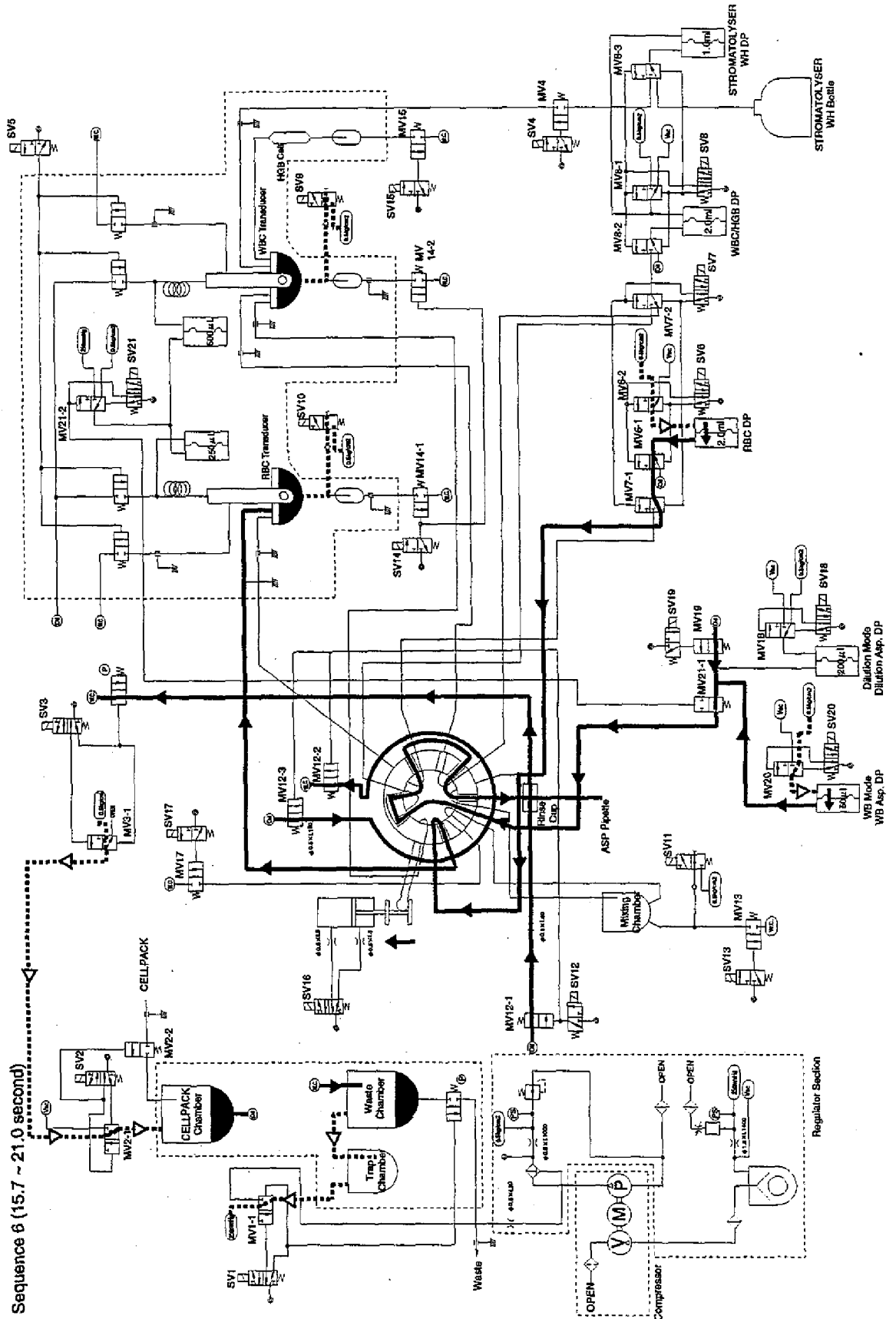

**Sequence 6 (21.0 ~ 21.8 sec.)**

(1) Reagent Aspiration by DP

At the timing of 21.0 sec., SV6 and SV8 are deactivated. RBC and WBC/HGB DPs aspirate 2.0 mL each of diluent, and STROMATOLYSER-WH DP aspirates 1.0 mL of Lyse reagent respectively to prepare for the next sequence.

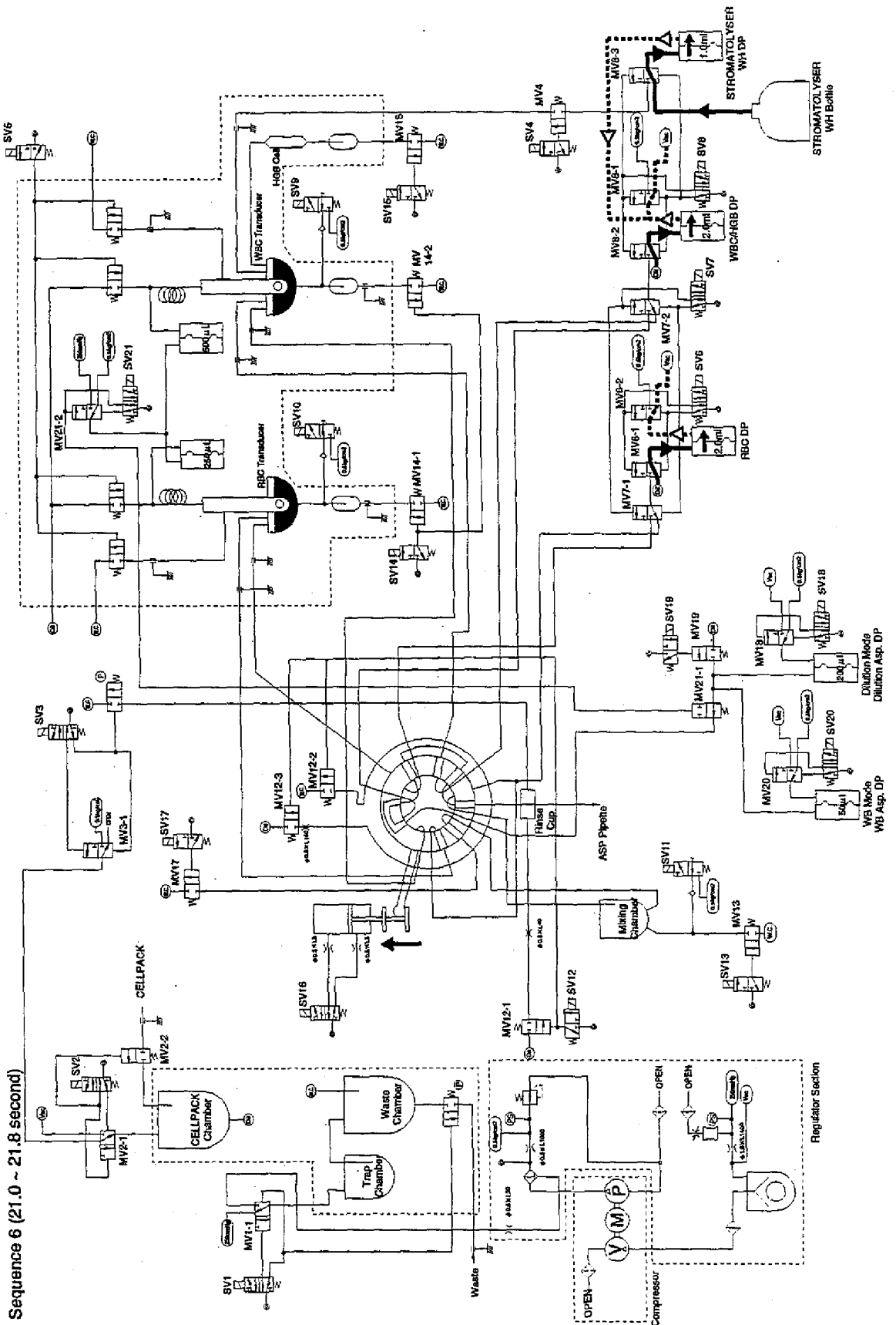

Sequence 6 (21.0 ~ 21.8 second)

**Sequence 7 (21.8 - 25.3 sec.)**

(1) Removing Air in WBC/RBC TD

SV5 is activated between 21.8 sec. and 22.8 sec. to aspirate diluent by the vacuum (250 mmHg) in Waste Chamber and fill it in WBC/RBC TD. This operation is performed to remove the air remained around the aperture in the previous sequence.

(2) Rinsing RBC Second Dilution Line

SV17 is activated between 21.8 sec. and 22.5 sec. to connect MV17 and Waste Chamber. By applying vacuum (250 mmHg) on Waste Chamber, the diluent in Mixing Chamber passes through RBC Second Dilution line and flows finally into Waste Chamber, which enables RBC Second Dilution line to be rinsed.

(3) Sample Aspiration into HGB Flow Cell

SV15 is activated between 23.5 sec. and 24.5 sec. to connect MV15 and Waste Chamber. By applying the vacuum (250 mmHg), the sample in WBC TD Chamber flows into HGB Flow Cell.

Sequence 7 (21.8 ~ 25.3 second)

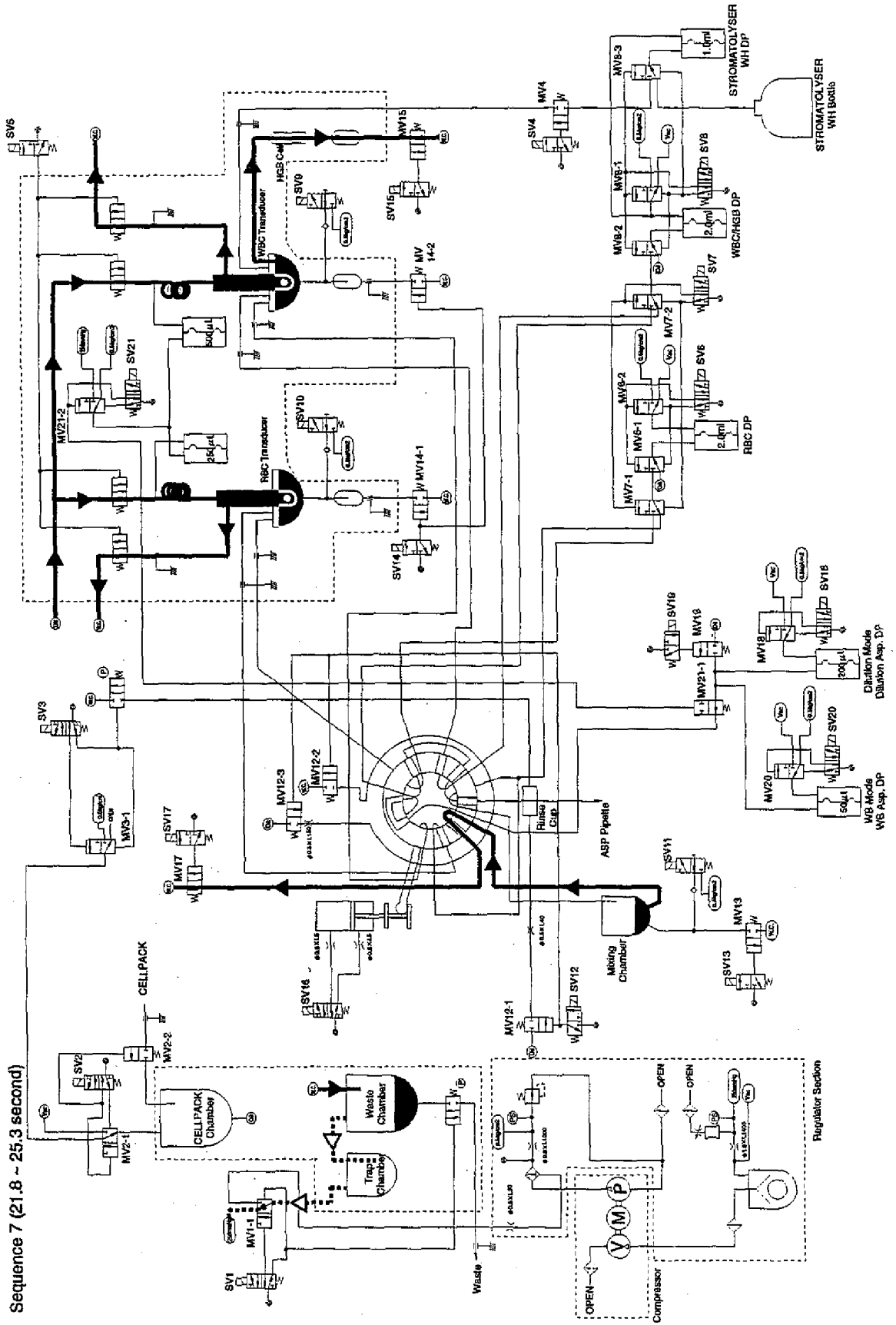

**Sequence 7 (25.3 - 37.8 sec.)**

(1) RBC Counting

SV21 is activated between 25.3 sec. and the end of Sequence 8 to apply vacuum of 250 mmHg on RBC Counting DP to aspirate the sample in RBC TD Chamber and start counting. By the aspiration of RBC Counting DP, total 250  $\mu$ L of sample passing through the aperture of the TD is counted.

(2) WBC Counting

SV21 is activated between 25.3 sec. and the end of Sequence 8 to apply vacuum of 250 mmHg on WBC Counting DP to aspirate the sample in WBC TD Chamber and start counting. By the aspiration of WBC Counting DP, total 500  $\mu$ L of sample passing through the aperture of the TD is counted.

**Sequence 8 (37.8 - 39.3 sec.)**

(1) HGB A/D Convert

Detector Block detects the emitted light beam in HGB Flow Cell and performs the A/D Convert between 38.3 sec. and 39.3 sec. This operation is performed five times with an interval of 0.2 sec.

Sequence 7 (25.3 ~ 37.8 second)

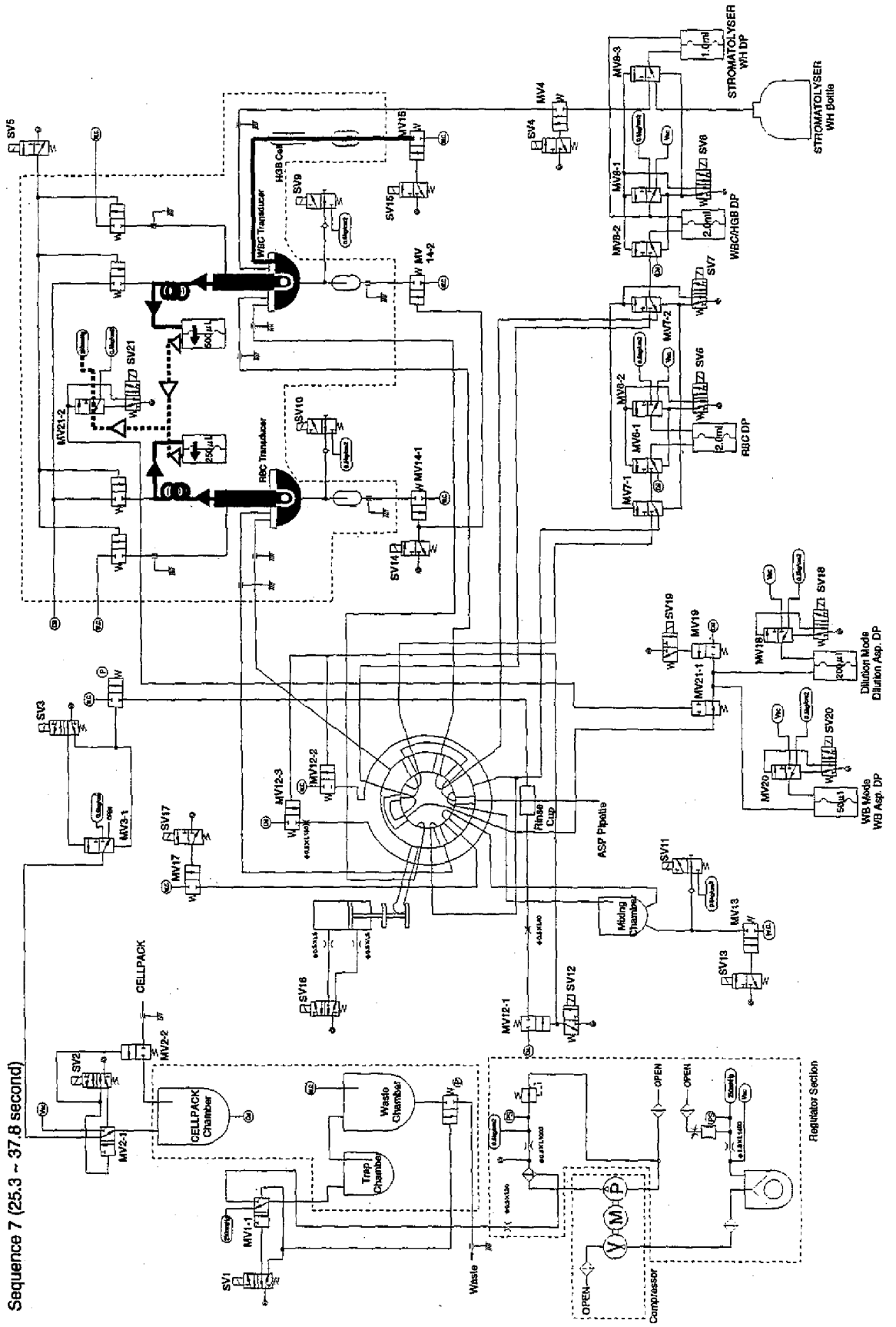



**Sequence 9 (39.3 ~ 42.5 sec.)**

(1) Clog Removal

At the end of Sequence 8, SV21 closes to apply 0.5 kg/m<sup>2</sup> pressure on RBC/WBC Counting DP to perform the draining operation and avoid clogs occurred during counting.

(2) Dispensing Diluent into WBC/RBC TD

SV5 is activated between 39.3 sec. and 40.0 sec. to apply vacuum of 250 mmHg on Waste Chamber to flow the liquid in TD into Waste Chamber and fill WBC/RBC TD with clean diluent.

(3) Draining WBC/RBC TD Chamber

SV14 is activated between 40.2 sec. and 42.5 sec. to connect MV14-1 and MV14-2 with Waste Chamber. By applying vacuum (250 mmHg) on Waste Chamber, the liquid in WBC/RBC TD Chamber is drained into Waste Chamber.

In order to remove the remained liquid in Air Bubble Mixing line (between Non-Return Valve and T-Joint), SV9 and SV10 perform the open/close operation four times with an interval of 0.2 sec. with high speed to avoid Air Bubble Mixing line to be contaminated by the waste.

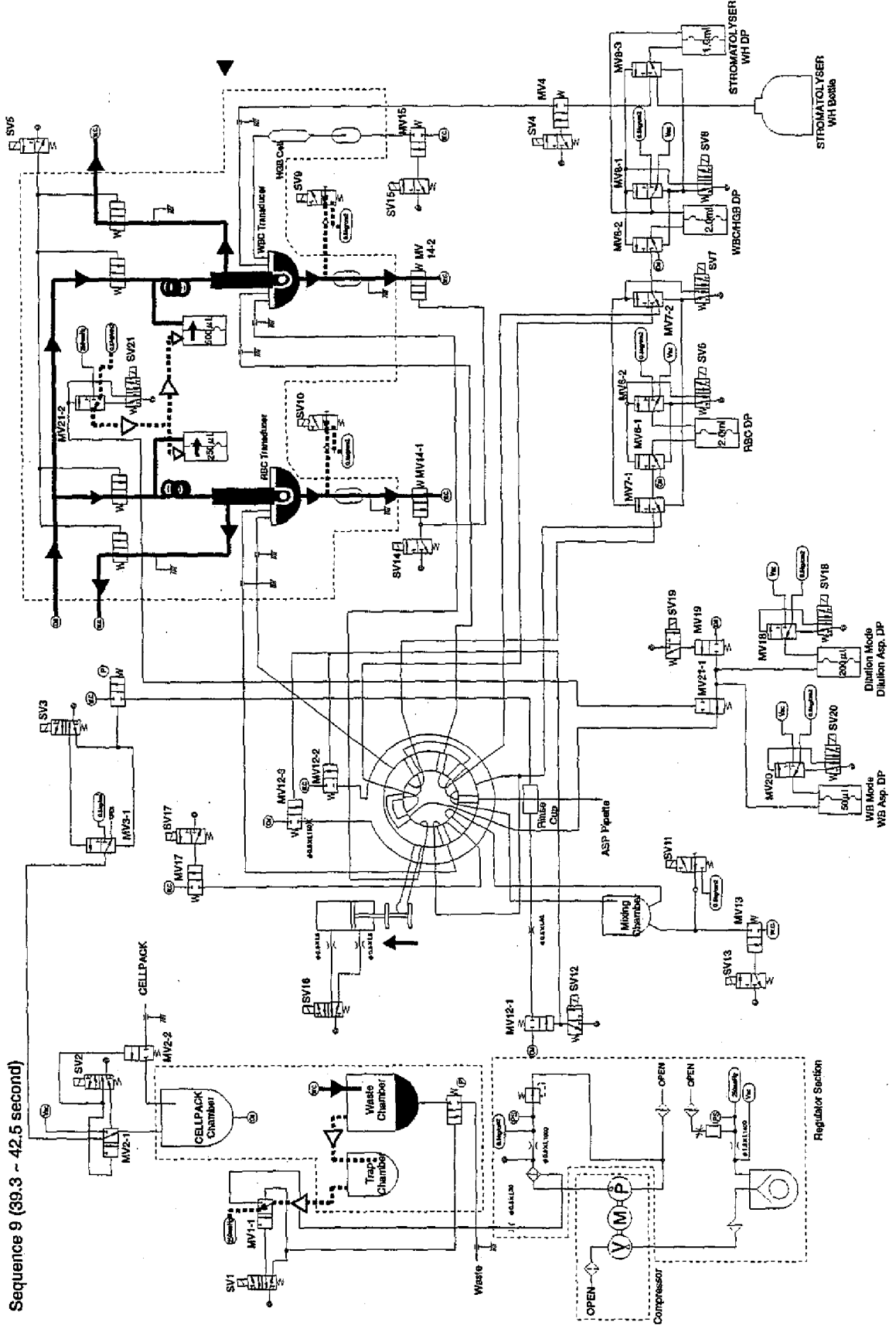

Sequence 9 (39.3 ~ 42.5 second)

**Sequence 9 (42.5 sec. ~ 44.0 sec.)**

(1) Rinsing Second Dilution Line and RBC TD Chamber

At the timing of 42.5 sec., SV6 is activated to enable RBC DP to dispense 2.0 mL of diluent. The diluent passes through RBC Second Dilution line and flows into RBC TD Chamber. By this operation, the Dilution line and TD Chamber are rinsed.

(2) Rinsing WBC Dilution Line and WBC TD Chamber

At the timing of 42.5 sec., SV8 is activated to enable WBC DP to dispense 2.0 mL of diluent. The diluent passes through WBC Dilution line and flows into WBC TD Chamber. By this operation, the Dilution line and TD Chamber are rinsed.

Sequence 9 (42.5 ~ 44.0 second)

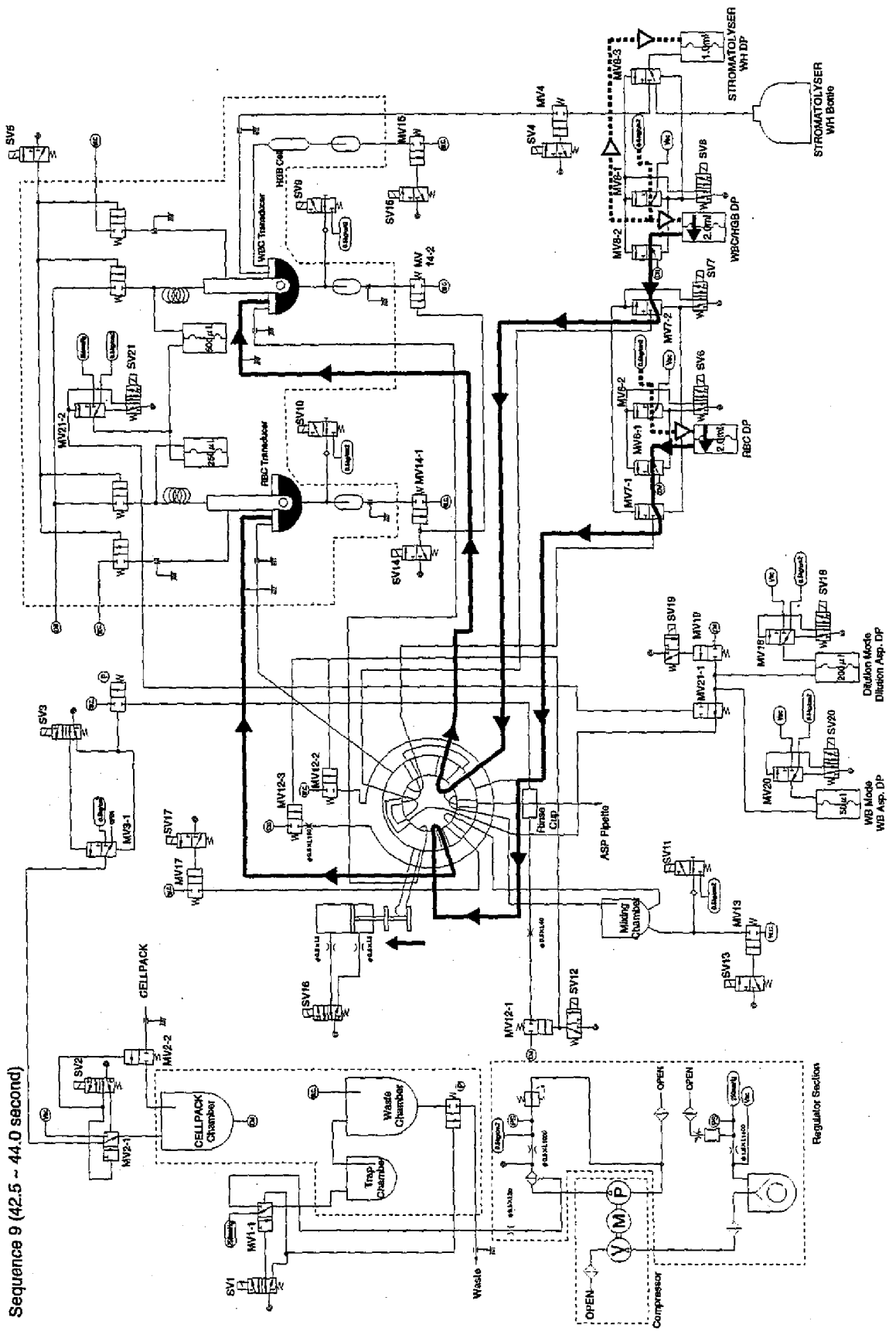

**Sequence 9 (44.0 sec. ~ 46.5 sec.)**

(1) Reagent Aspiration

At the timing of 44.0 sec., SV6 and SV8 are deactivated. RBC and WBC/HGB DPs aspirate 2.0 mL each of diluent to prepare for the next sequence.

(2) SRV Rotation

At the timing of 44.0 sec., SV16 is activated to drive the piston controlling the SRV rotation. SRV rotates in the CCW direction (seeing from the left side of the instrument) to prepare for the line rinsing. SRV keeps this position until the timing of 52.0 sec.

(3) Draining HGB Flow Cell

SV15 is activated between 45.8 sec. and 46.5 sec. to connect MV15 and Waste Chamber. By applying vacuum (250 mmHg) on Waste Chamber, the diluent in WBC TD Chamber is aspirated into HGB Flow Cell and rinse it.

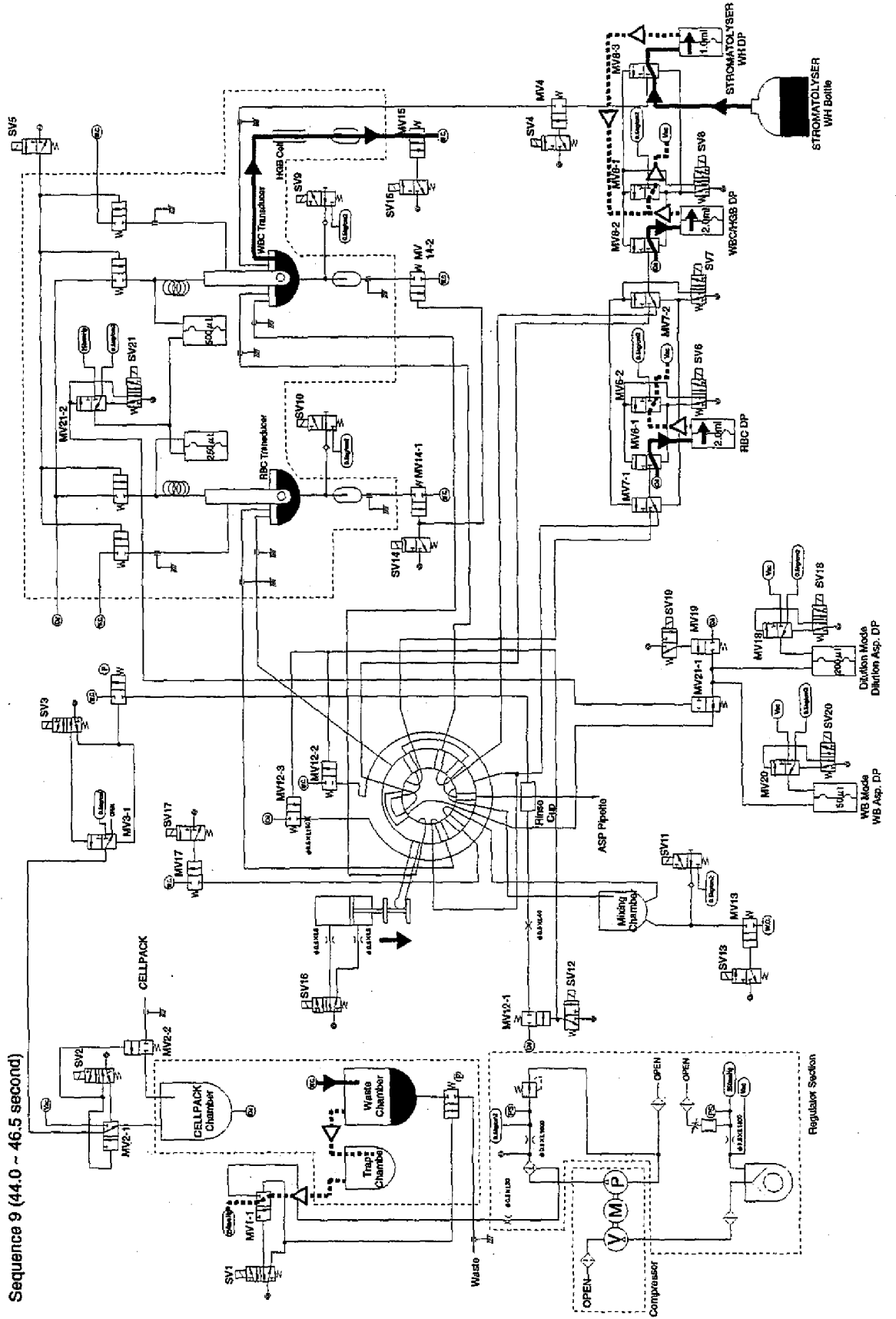

**Sequence 9 (46.5 sec. ~ 48.0 sec.)**

(1) Rinsing WBC Dilution Line and WBC TD Chamber

At the timing of 46.5 sec., SV8 is activated to make WBC DP dispense 2.0 mL of diluent via WBC Dilution line and flow it into WBC TD Chamber, which rinses the Dilution line and TD Chamber.

(2) Rinsing RBC Mixing Chamber

At the timing of 46.5 sec., SV6 is activated to make RBC DP dispense 2.0 mL of diluent via RBC First Dilution line and flow it into Mixing Chamber, which rinses the RBC First Dilution line and Mixing Chamber.

Sequence 9 (46.5 ~ 48.0 second)

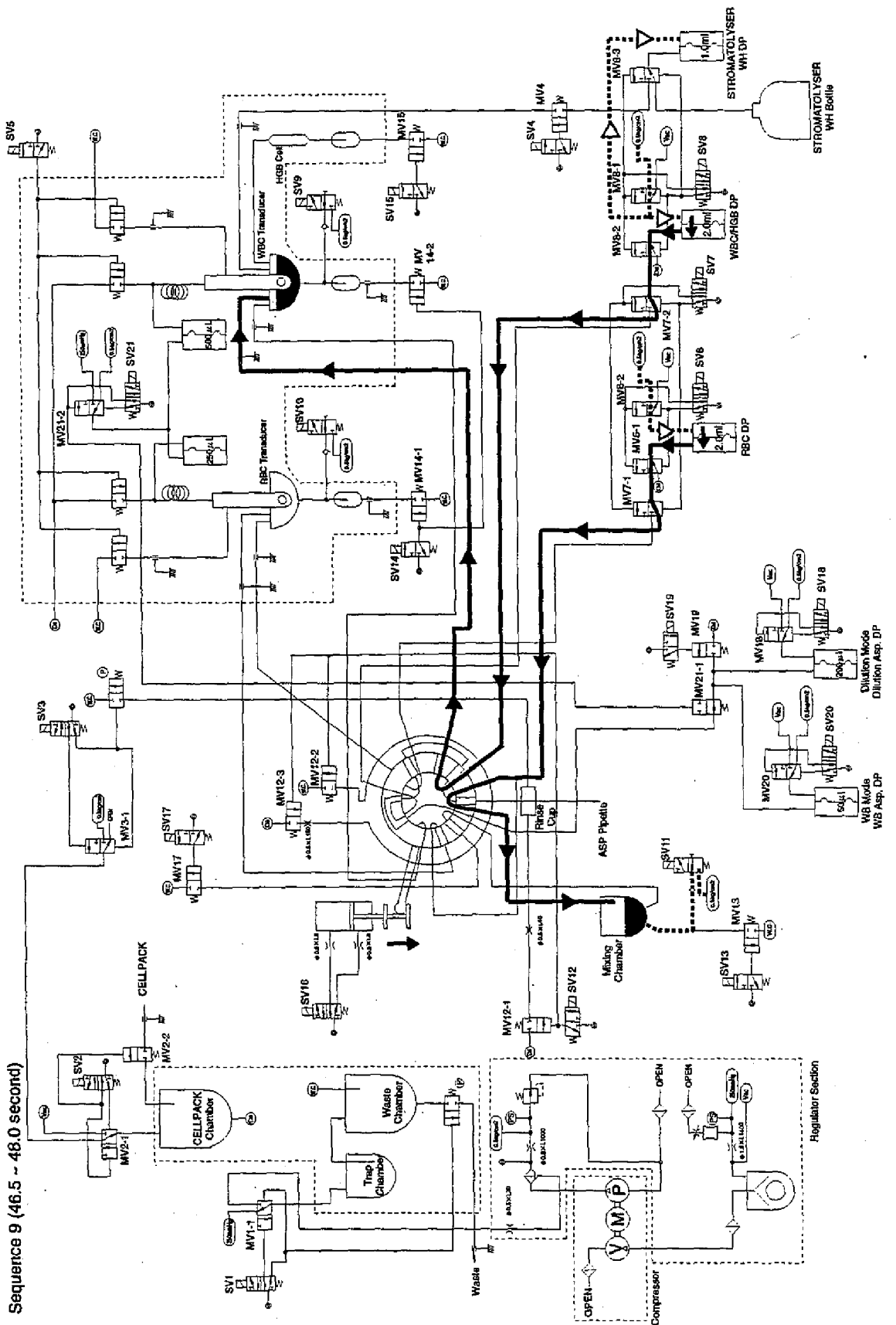



**Sequence 10 (48.0 sec. ~ 50.5 sec.)**

(1) Reagent Aspiration

At the timing of 48.0 sec., SV6 and SV8 are deactivated. RBC and WBC/HGB DPs aspirate 2.0 mL each of diluent to prepare for the next sequence.

(2) Draining WBC/RBC TD Chamber

SV14 is activated between 48.3 sec. and 50.5 sec. to connect MV14-1 and MV14-2 with Waste Chamber. By applying vacuum (250 mmHg) on Waste Chamber, the liquid in WBC/RBC TD Chamber is drained into Waste Chamber.

Sequence 9 (48.0 ~ 50.5 second)

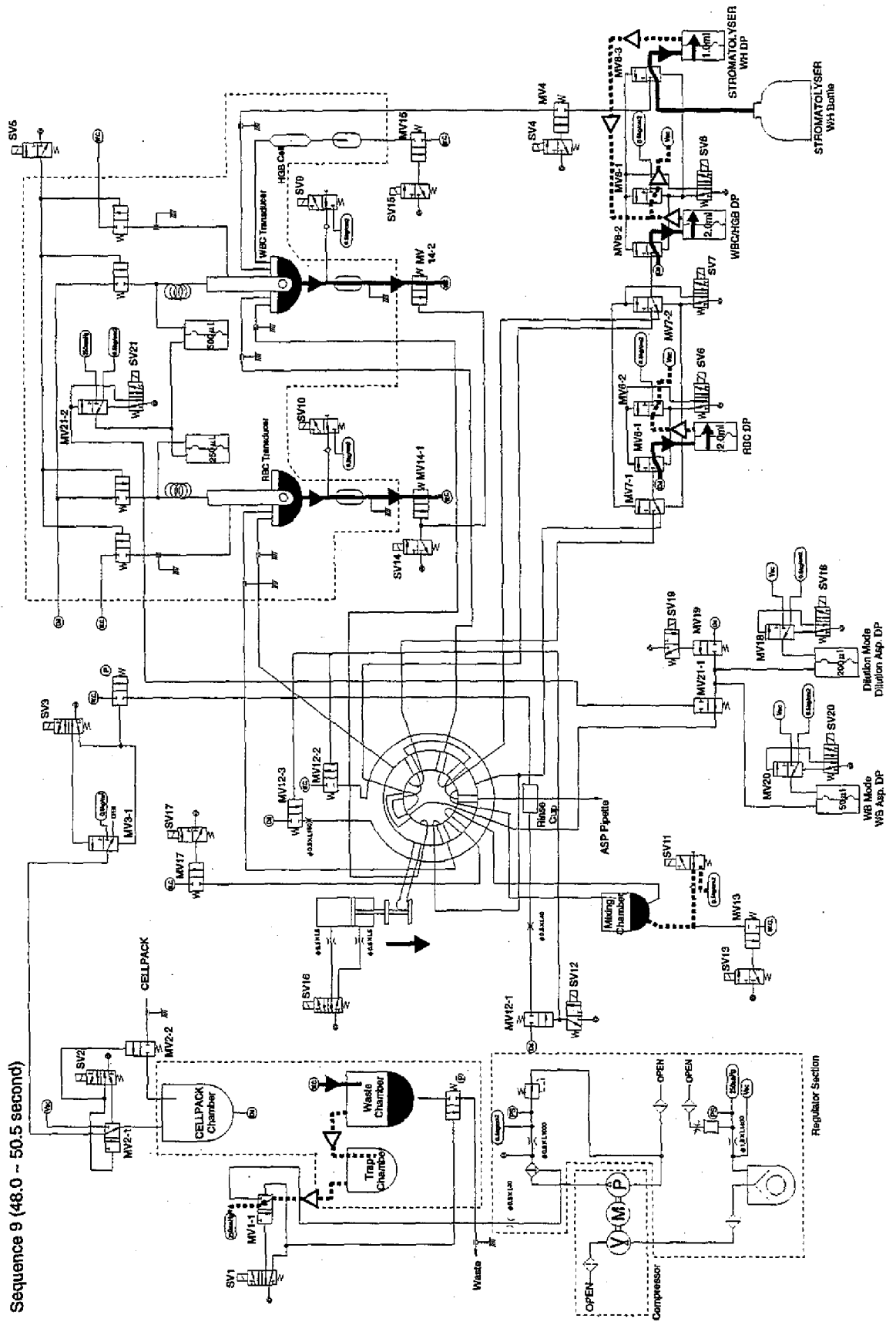

**Sequence 11 (50.5 sec. ~ 57.5 sec.)**

(1) Aspirating Diluent into CELLPACK Chamber

At the timing of 50.5 sec., SV2 is activated to connect MV2-1 and VACUUM line, which enables the diluent in the reagent cubitainer outside Main Unit into CELLPACK Chamber. This operation continues until Float Switch turns OFF.

(2) Rinsing Dilution Line in RBC/WBC Pre Diluted Mode

At the timing of 50.5 sec., SV6, SV7 and SV8 are activated to make MV7-1 and MV7-2 switch to the PD Mode. RBC and WBC/HGB DPs dispense the diluent into each of RBC/WBC TD Chambers via each of RBC/WBC PD Mode Dilution lines respectively. This operation enables RBC/WBC PD Mode Dilution line to be rinsed.

(3) Draining Waste Chamber

SV1 is activated between 53.5 sec. and 56.5 sec. to release Pinch Valve controlling the draining of Waste Chamber. At the same time, MV1-1 and PRESSURE line are connected to apply pressure on Waste Chamber to drain the waste outside Main Unit via the draining line.

Sequence 9 (50.5 - 57.5 second)

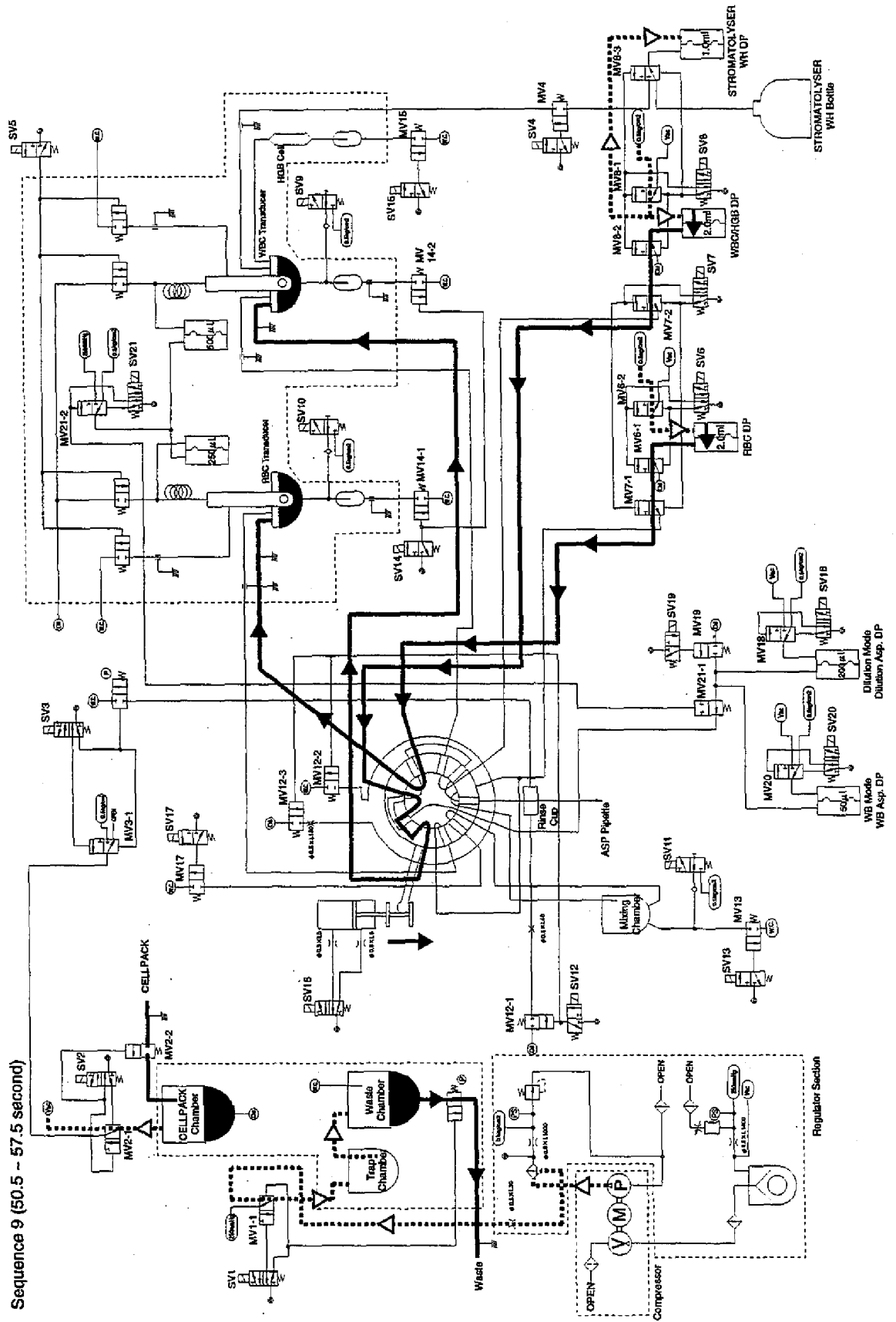

**Sequence 9 (57.5 sec. ~ 59.0 sec.)**

- (1) Removing Air Bubble in Waste Chamber  
SV3 is activated between 57.6 sec. and 58.4 sec. to apply pressure on CELLPACK Chamber to prevent the air bubble generated at the upper part of the chamber when aspirating diluent from flowing back into the vacuum line.
- (2) Aspirating Reagent  
At the timing of 57.5 sec., SV6 and SV8 close, and then RBC and WBC/HGB DPs aspirate 2.0 mL each of reagent to prepare for the next sequence respectively.
- (3) SRV Rotation  
At the timing of 52.0 sec., SV16 is deactivated and SRV rotates in the CW direction to return to the home position.
- (4) Rinsing RBC/WBC Count Line  
At the timing of 57.7 sec., SV21 is activated, and RBC/WBC Counting DPs aspirate the diluent in the TDs and rinse RBC/WBC count lines. At the timing of 58.5 sec., SV21 closes to drain the diluent after rinsing by the DP.

Sequence 9 (57.5 - 59.0 second)

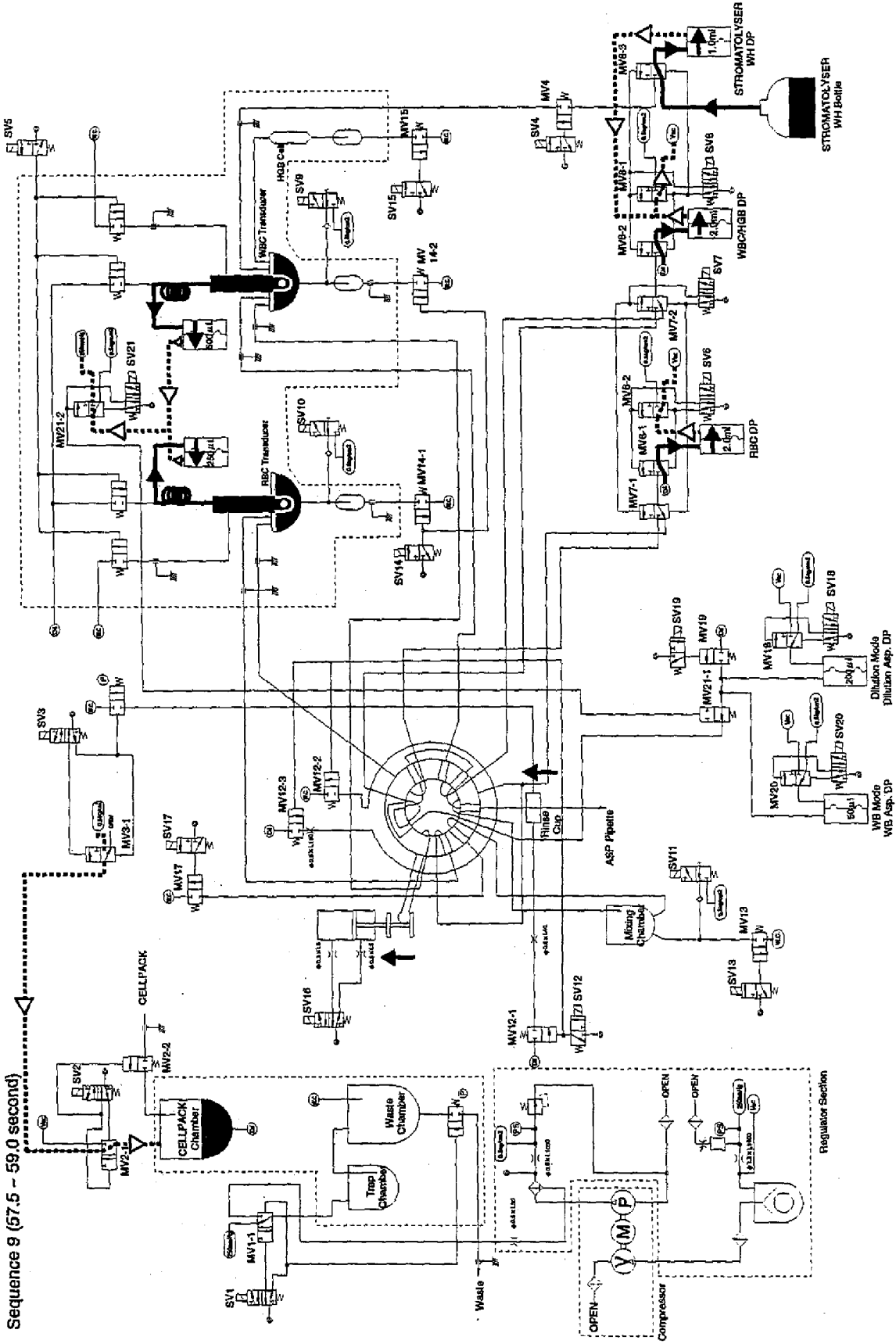

**Sequence 10 (59.0 sec. ~ 60.0 sec.)**

(1) Removing Air in WBC, RBC TDs

SV5 is activated between 59.2 sec. and 60.0 sec. to apply vacuum on Waste Chamber to aspirate the diluent and fill WBC/RBC TDs with it, which enables the air remained around the apertures in the previous sequence to be removed.

(2) Draining HGB Flow Cell

SV15 is activated between 59.2 sec. and 60.0 sec. to connect MV15 and Waste Chamber. By applying the vacuum (250 mmHg) on Waste Chamber, the diluent in WBC TD Chamber is dispensed into HGB Flow Cell to clean the Cell. At the same time, the clean diluent remains in Flow Cell to avoid the precipitation of the crystals.

(3) Initializing Rinse Cup Position (Returning to the Home Position)

From the timing of 57.7 sec., the stepper motor is driven to return Rinse Cup to the home position.

Sequence 10 (59.0 - 60.0 second)

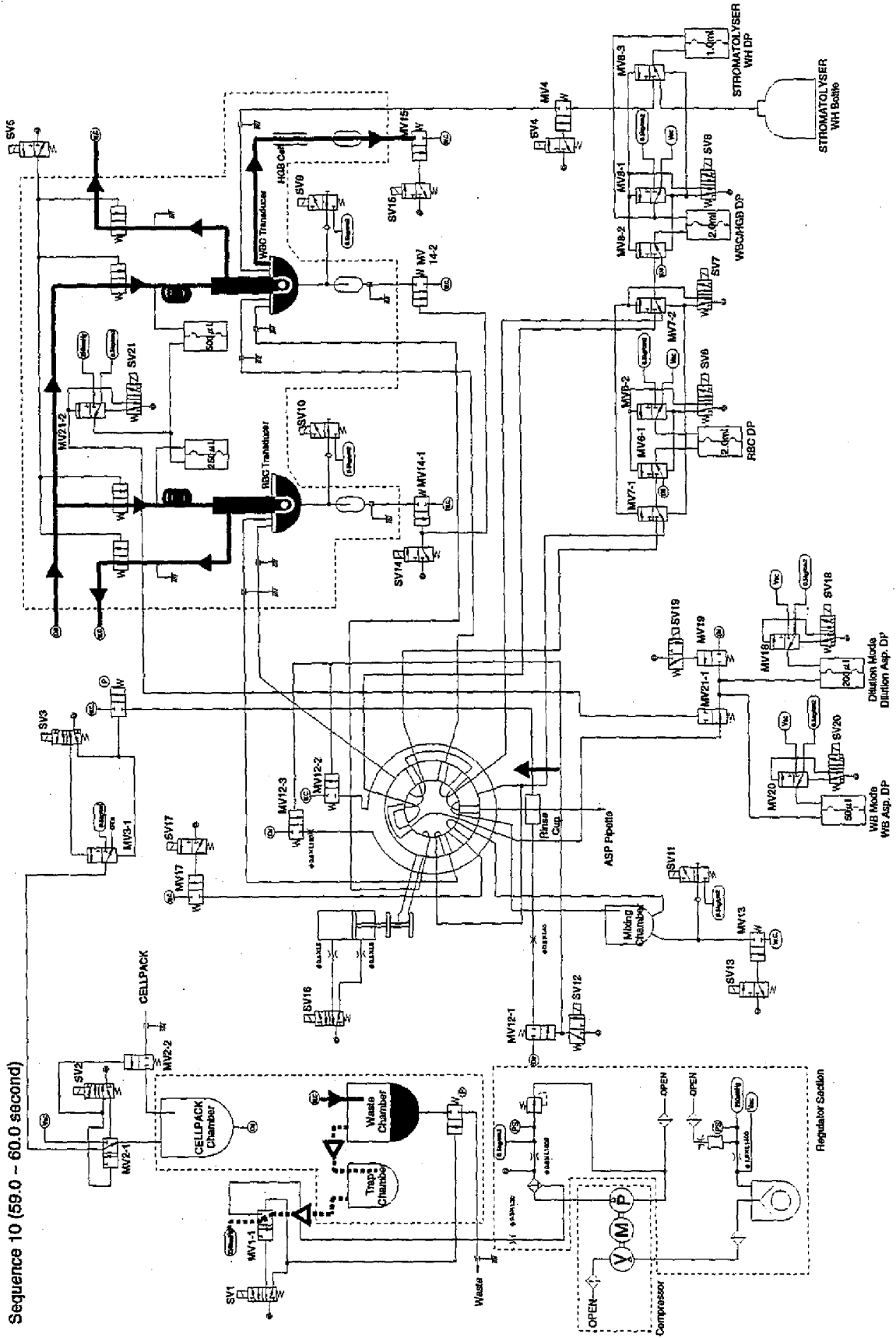



### 2.12.2 Pre-Diluted Mode

The following is only the different part of the analysis flow in KX-21 Pre-Diluted Mode from Whole Blood Mode in accordance with Timing Charts in *Section 7*.

#### PD Mode Sequence 1 (0.0 ~ 19.5 sec.)

(1) Sample Aspiration

Pressing Start Switch activates SV18, applies vacuum on DP (Diaphragm Pump) for aspirating the diluted sample, and then aspirates 200  $\mu$ L of diluted sample blood through Aspiration Pipette. The aspirated diluted sample passes through SRV (Sample Roter Valve) and waits for the next sequence. SV18 is operating from 0.0 sec. to 19.5 sec. of Sequence 1.

Pre-diluted Mode Sequence 1 (0.0 - 19.5 second)

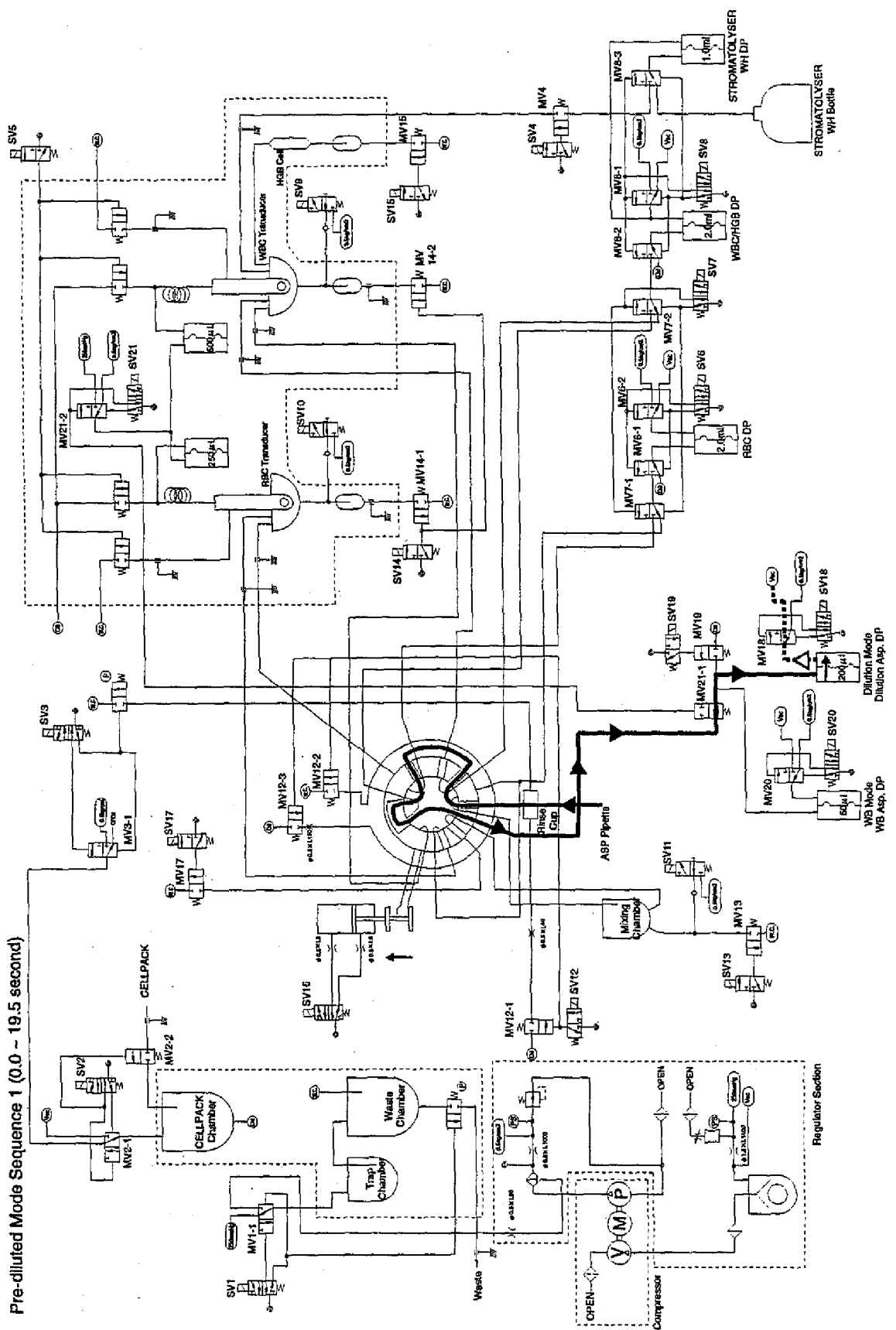

**PD Mode Sequence 5 (14.0 ~ 16.0 sec.)**

(1) Diluting RBC Sample

At the timing of 14.0 sec., SV6 and SV7 are activated, which enables RBC DP to dispense 2.0. mL of diluent and 2.08  $\mu$ L of 1 : 26 RBC Sample cut away by SRV into the RBC TD Chamber through the RBC PD Mode Dilution line. This enables the sample to be diluted by 25,000 times in RBC TD Chamber.

(2) Diluting WBC Sample

At the timing of 14.0 sec., SV7 and SV8 are activated, which enables WBC DP to dispense 2.0. mL of diluent and 78  $\mu$ L of WBC Sample cut away by SRV into the WBC TD Chamber. At the same time, STOROMATOLYSER-WH DP dispenses 1.0 mL of Lyse reagent into WBC TD Chamber, which enables the sample to be diluted by 10,000 times in WBC TD Chamber.

Pre-diluted Mode Sequence 1 (14.0 ~ 16.0 second)

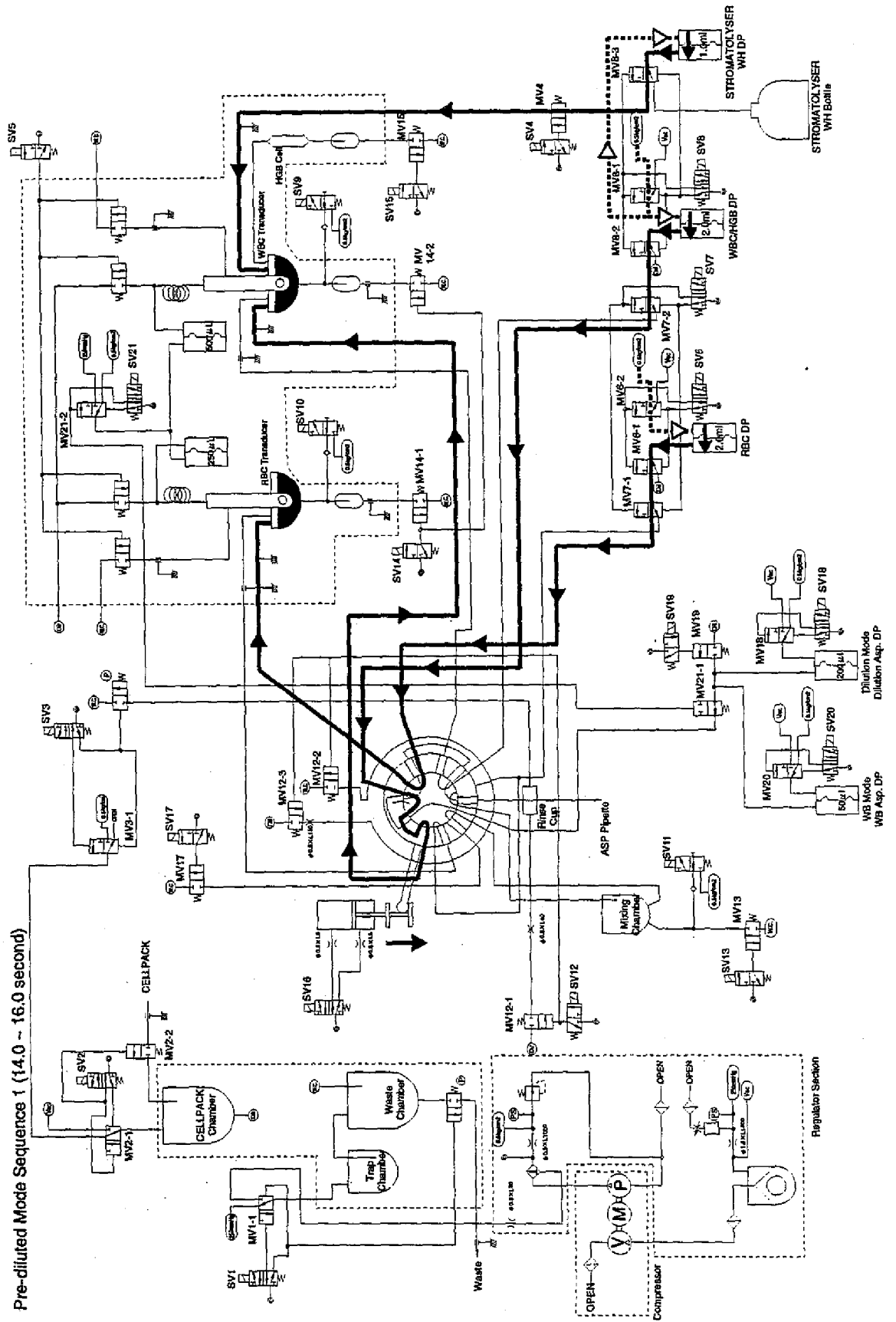

## 2.13 PNEUMATIC & HYDRAULIC PARTS

Pneumatic Controls are used to regulate the air flow, and to change the direction of flow.



Name & Symbol	Figures	Used for
<p><b>Regulator</b></p> 		<p>Regulator is used to regulate air flow rate which is adjusted by turning the Adjustment Knob. Only one regulator which is shown in left figure is used in the KX- 21. This regulator is used to regulate 2.0 kg/ cm air pressure into 0.5 kg/ cm pressure with an air filter and auto draining mechanism.</p>
<p><b>Non- Return Valve</b></p> 		<p>The Non- return Valve permits hydraulic flow in only one direction from, A to B. No hydraulic flow will occur from B to A.</p>
<p><b>Orifice</b></p> 		<p>An orifice controls the rate of air flow or the volume of air with respect to time. These orifice are identical to those used in the pneumatic and hydraulic system. There are several kinds of orifices each of which permits a different flow rate.</p>

Table 2-1 Pneumatic and Hydraulic Parts (1)

Name & Symbol	Figures	Used for						
<p style="text-align: center;"><b>Bellows</b></p> 		<p>The bellows unit in the KX- 21 is used to regulate the vacuum (480 mmHg or more) into 250 mmHg. This unit consists of bellows and small air tank. If the inner vacuum exceeds the mechanical pressure of bellows, vacuum is released from its top port. If the mechanical pressure exceeds the inner vacuum of bellows, vacuum increases after the top port is closed by the needle valve. ( See below figures.)</p> 						
<p><b>3-ports type Solenoid Valve</b></p>  <p><b>5-ports type Solenoid Valve</b></p>  <table border="1" data-bbox="256 1503 523 1621"> <thead> <tr> <th colspan="2">Status of Solenoid Valve</th> </tr> </thead> <tbody> <tr> <td>①</td> <td>SV is turned ON.</td> </tr> <tr> <td>②</td> <td>SV is OFF.</td> </tr> </tbody> </table>	Status of Solenoid Valve		①	SV is turned ON.	②	SV is OFF.		<p>Two types of Solenoid valves (3-ports and 5- ports type) are used in the hydraulic system. Solenoid Valves are driven by applying 12 V-DC which are controlled by computer program, and are used to control the pneumatics pressure to drive Master valves, Air cylinder, or Air Bubble Mixing.</p> <p>Solenoid valve symbol has two boxes in its drawing. Arrows in these boxes indicate the status of connection. Status ① or ② shown in "Name &amp; symbol" column will be switched by the activation of solenoid valve by the activation or deactivation of solenoid valve respectively.</p>
Status of Solenoid Valve								
①	SV is turned ON.							
②	SV is OFF.							

Table 2-1 Pneumatic and Hydraulic Parts (2)

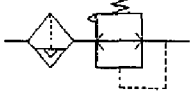
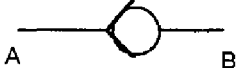
Name & Symbol	Figures	Used for						
<p><b>2 ports type Master Valve</b></p> <p><b>3 ports type Master Valve</b></p> <table border="1" data-bbox="323 813 592 931"> <thead> <tr> <th colspan="2">Status of Master Valve</th> </tr> </thead> <tbody> <tr> <td>①</td> <td>MV is turned ON.</td> </tr> <tr> <td>②</td> <td>MV is OFF.</td> </tr> </tbody> </table>	Status of Master Valve		①	MV is turned ON.	②	MV is OFF.		<p>Master valves in KX- 21 are used to switch Hydraulic lines (liquid, 0.5 kg/cm<sup>2</sup> pressure, and 480 mmHg / 250 mmHg vacuum). Two types of Master Valve ( 2 ports and 3 ports type) are used in the hydraulic system. Master Valves are driven by 2 kg/ cm<sup>2</sup> air pressure controlled by Solenoid valves.</p> <p>Master valve symbols has also two boxes in its drawing. Arrows and lines in these boxes indicates hydraulic ways. Status ① or ② shown in "Name and symbol" Column will be switched by the activation or deactivation of master valve, respectively</p>
Status of Master Valve								
①	MV is turned ON.							
②	MV is OFF.							
<p><b>Sample Rotor Valve &amp; Air Cylinder</b></p>		<p>Sample Rotor Valve Mechanism is driven by the air cylinder. The air cylinder is provided with two (A and B) ports, (A) for pneumatic activation to rotate the SRV counter clockwise and the other (B) for pneumatic deactivation to reset the SRV. The 2 kg/ cm<sup>2</sup> pressure for these action are supplied by a 3 ports type solenoid valve.</p>						

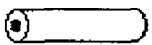
Table 2-1 Pneumatic and Hydraulic Parts (3)

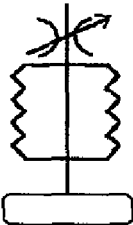
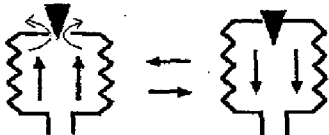
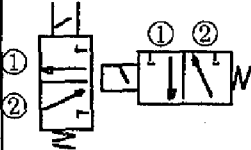
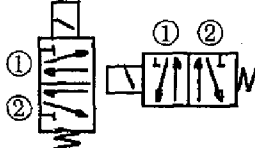

Name & Symbol	Figures	Used for
<p><b>Diaphragm Pump</b></p> <p>Pneumatics    Hydraulics</p> 		<p>Seven Diaphragm Pumps are used in the hydraulic system. Diaphragm Pumps are driven by 0.5 kg/cm air pressure and 480 mmHg vacuum controlled by Master valves, and dispenses or aspirates constant volume of liquid. Diaphragm Pumps are drawn by left symbols in sequence flow charts.</p> <p>Diaphragm Pump has two nipples on it. One is to connect to pneumatic system (0.5 kg/cm<sup>2</sup> pressure or 480 mmHg Vacuum), and the other is to hydraulic system. Either of pressure or vacuum is always supplied to the pneumatic side nipple. If the vacuum is supplied to pneumatic side nipple, the fixed volume of liquid is aspirated into the diaphragm pump. If the pressure supplied, the fixed volume of liquid is dispensed from the</p>
<p><b>Manometer</b></p> 		<p>Ball float manometers are located in detector blocks, and are used to detect constant volume of diluted sample which are aspirated through the transducer aperture.</p>
<p><b>Isolation Chamber</b></p> 		<p>These Isolation Chambers are used to isolate the liquid in detector block from the remained hydraulic line in the system in order not to be influenced by the external noise through the hydraulic line.</p>

Table 2-1 Pneumatic and Hydraulic Parts (4)





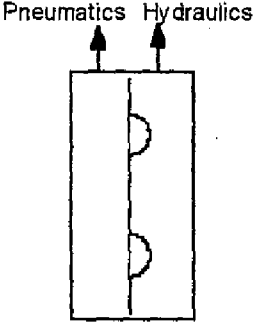
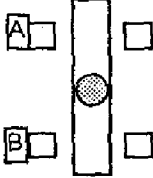
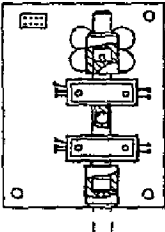



Name & Symbol	Figures	Used for
<b>Transducer Chamber</b> 		<p>Diluted samples of WBC or RBC are dispensed into each transducer chamber, mixed by air bubbles, and constant volume of the sample are aspirated through the aperture.</p>
<b>Pressure Gauge</b> 		<p>Four pressure gauges are used in the system to check the following pressures or vacuums.</p> <p>Pneumatic unit  1: 2.0 kg/cm<sup>2</sup> pressure  2: 480 mmHg Vacuum  Main Unit  3: 0.5 kg/cm<sup>2</sup> pressure  4: 250 mmHg Vacuum</p>
<b>2 kg/cm<sup>2</sup> pressure source</b> 		<p>2 kg/cm<sup>2</sup> pressure is used to drive the master valves and SRV air cylinder. To make simple the hydraulic flow chart, the symbol in the column "Name and symbol" is used.</p>
 <b>Glass Chamber</b>		<p>Glass chambers with float switches are used as Waste Chamber, Diluent chamber, and lyse reagent chamber. 480 mmHg or 250 mmHg vacuum is applied into these chamber to aspirate or prime liquid. When exhausting the waste liquid in Waste Chamber, 0.5 kg/cm is applied instead of vacuum. Float switch is provided with these chambers to prevent overflow of these chamber.</p>
<b>Relief Valve</b> 		<p>The Relief Valve releases air pressure if the supplied air pressure exceed the preset value. This valve is adjusted by turning the knurled knob.</p>

Table 2-1 Pneumatic and Hydraulic Parts (5)

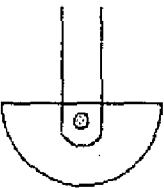
## SECTION 4 ADJUSTMENT

4.1	STANDARD SENSITIVITY ADJUSTMENT .....	4 - 1
	4.1.1 WBC and RBC Sensitivity Adjustment.....	4 - 1
	4.1.2 PLT Sensitivity Adjustment.....	4 - 3
4.2	HGB ADJUSTMENT .....	4 - 5
4.3	CLOG LEVEL ADJUSTMENT.....	4 - 7
4.4	PCB CHECKING AND ADJUSTMENT.....	4 - 8
	4.4.1 PCB No. 2135 (Analog Main).....	4 - 8
	4.4.2 PCB No. 6363 (Main CPU) .....	4 - 9
	4.4.3 PCB No. 4087 (Power Supply Unit) .....	4 - 10
4.5	PROGRAM VERSION UP PROCEDURES.....	4 - 11
4.6	MECHANICAL PARTS ADJUSTMENT .....	4 - 12
	4.6.1 SRV Position Adjustment .....	4 - 12
	4.6.2 Rinse Cup Position Adjustment.....	4 - 13

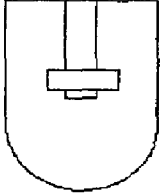
## SECTION 4 ADJUSTMENT

### 4.1 STANDARD SENSITIVITY ADJUSTMENT

#### 4.1.1 WBC and RBC Sensitivity Adjustment

Required reagent: CELLCHECK-400; Part No. 814-0022-6

- (1) Verify that the temperature of CELLPACK and the room temperature is within the range of 15 - 30°C.
- (2) Access to the Maintenance mode.
- (3) Press the Start Switch and verify WBC and RBC background count fall the range below:  
WBC background value  $\leq 0.30 \times 10^3/\mu\text{L}$   
RBC background value  $\leq 0.02 \times 10^6/\mu\text{L}$
- (4) Select 9. Service from SELECT menu.  
Select 2. Service Seq. and 3. Gain Adjustment from the submenu.
- (5) From the Gain Adjustment menu, select 1: WBC/RBC. The WBC/RBC Gain Adjustment screen will appear.

S	*Gain Adjustment*	
	Ready	
	W-MFV	R-MCV
TARGET		
1		
2		
3		
MAX-MIN		
RATIO(%)		
RESULT		

Figure 4-1: WBC/RBC Gain Adjustment Display

"\*Gain Adjustment\*" will appear in the system status area.

The data processing area includes following items:

- TARGET: Area for entering the target value  
1, 2 and 3: Area that displays the 3 analysis values  
MAX-MIN: Area that displays the difference between the maximum and minimum of the 3 analysis values  
RATIO(%): Area that displays the calculated compensation ratio  
RESULT: Area that displays the analysis values after they are compensated

- (6) Enter the TARGET values using the numeric and decimal keys.  
When the Gain Adjustment screen is opened, the area in which you enter the W-MFV target values will be reversed. Input the W-MFV and R-MCV TARGET values calculated as below:

W-MFV TARGET =  $1.354 \times$  (Target MFV value provided for each CELLCHECK-400 lot)

R-MCV TARGET =  $1.26 \times$  (Assay value MCV of CELLCHECK-400/CC-108)

The acceptable range for each parameter is 0.0 to 999.9. If the input range is exceeded, an alarm will sound and the data entry is ignored.

For each parameter, numerals that are not significant digits will be cut off. For example, if the WBC target is entered as 172.05, the set value will be 172.0.

[C] key functions as backspace to delete one character.

If a target value has already been entered, the previous value will be deleted upon any key entry.

- (7) To confirm, either press the [ENTER] key or move to the next item with the [→] and [←] keys. If you press the [ENTER] key, the reverse display will shift to the right.
- (8) Press the [SELECT] key. The confirmation message will appear.

Confirm Data?	Cont.	Set	Cancel
---------------	-------	-----	--------

**Figure 4-2: Gain Adjustment Confirmation Message**

If you select [Cont.], you can continue to enter target values.

If you select [Set], the target value will be confirmed and the sample will be ready for analysis.

If you select [Cancel], gain adjustment processing will be canceled and the system will return to the Ready Screen.

- (9) Open the Detector Cover by loosening the fixing screw.
- (10) Mix CELLCHECK-400 ampules vigorously, and pour it into the DB-1 sample beaker.
- (11) Pour approx. 3.5 mL of CELLCHECK-400 into the WBC transducer chamber, and approx. 2.5 mL into the RBC transducer chamber.
- (12) Close the Detector Cover, and press the Start Switch.  
The recount analysis sequence will be performed automatically three times and the three analysis values (1 to 3), difference between the maximum and minimum (MAX-MIN), and compensation ratio (RATIO%) will be calculated.

S	*Gain Adjustment*		▷▷▷▷▷▷▷▷
	Ready		
	W-MFV	R-MCV	
TARGET	172.0	134.8	
1	173.5	132.8	
2	175.5	131.8	
3	174.5	132.3	
MAX-MIN	2.0	1.0	
RATIO(%)	98.6	101.9	
RESULT	172.0	134.8	
Execute Settings?	Yes	No	

**Figure 4-3: WBC/RBC Gain Adjustment Display**

- (13) Analysis is performed once again and display the analysis values (RESULT). Verify that the followings are all satisfied.

- MAX-MIN ≤ 4 [fL]
- RATIO (%) - 100±50
- RESULT = TARGET±2 [fL]

- (14) If you select [Yes], the gain adjustment value will be updated and the system will return to the Ready Screen.  
If the built-in printer is connected, the fourth analysis values and compensation ratio will be printed.

**NOTE:**

If you select [No], none of the gain adjustment values will be updated, the current (prior-to-change) settings will be saved to the digital control, and the system will return to the Ready Screen.

If there is a parameter whose gain adjustment value was not calculated, that parameter's gain adjustment value will not be updated.

#### 4.1.2 PLT Sensitivity Adjustment

Required reagent: LATEX CALIBRATOR PLT (E); Part No. 951-0222-1

- (1) Verify that the temperature of CELLPACK and the room temperature is within the range of 15 - 30°C.
- (2) Remove the KX-21 Top Cover, then remove the Shield Cover No. 143 by loosening two each of flat screw M3x8 (SUS) so that you can access the adjustment VR5 on PCB No. 2135.
- (3) Access to the Maintenance mode.
- (4) Press the Start Switch and verify PLT background count falls the range below:  
PLT background value  $\leq 10 \times 10^3/\mu\text{L}$
- (5) Select 9. Service from SELECT menu.  
Select 2. Service Seq. and 3. Gain Adjustment from the submenu.
- (6) From the Gain Adjustment menu, select 2: PLT. The PLT Gain Adjustment screen will appear.

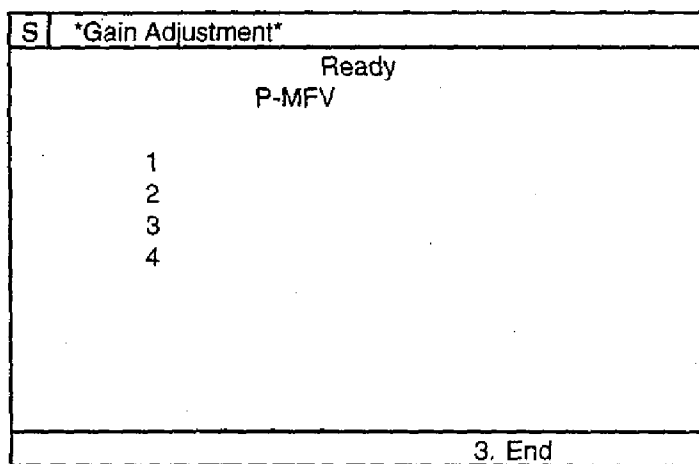

Figure 4-4: PLT Gain Adjustment Display

- (7) Mix the PLT Latex Calibrator by gently swirling vial.
- (8) Set the Latex Calibrator at the aspiration pipette and press the Start Switch to aspirate it.

- (9) When the analysis is completed, the P-MFV result will be displayed.

S	*Gain Adjustment*
	Ready
	P-MFV
1	12.0
2	
3	

**Figure 4-5:** Displayed the 1st Result of P-MFV

- (10) Adjust the VR5 on PCB No. 2135 so that the P-MFV falls within the acceptable range below.  
Turning the VR clockwise will increase the value.

$$\text{P-MFV} = (\text{Target MFV value provided for each LATEX CALIBRATOR PLT (PM/C2)}) \pm 0.2 \text{ [fL]}$$

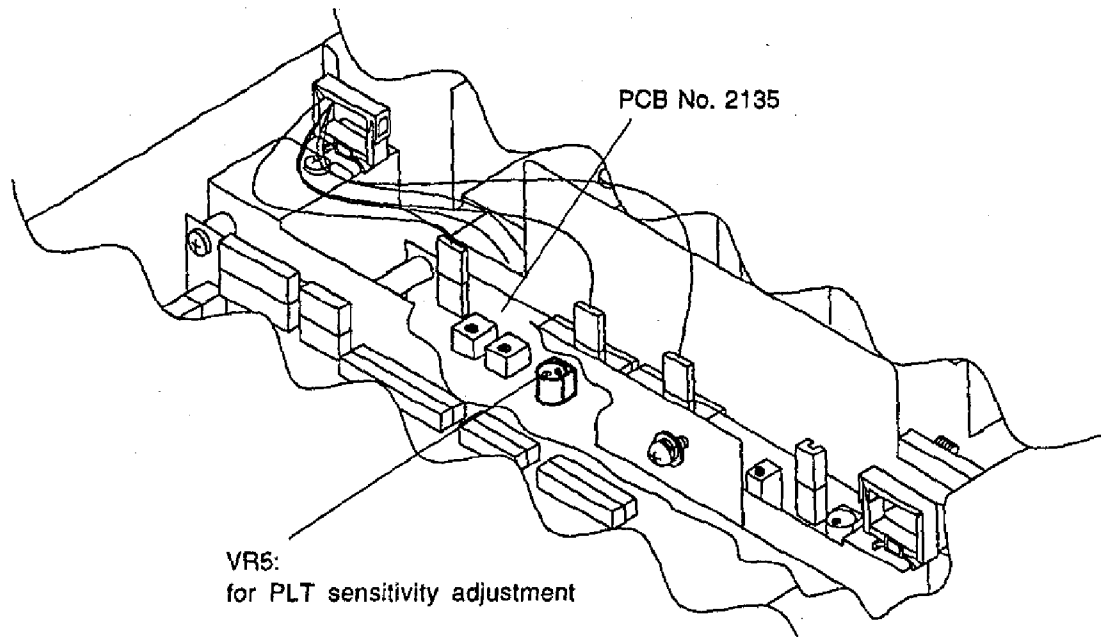

**Figure 4-6:** VR5 on PCB No. 2135

- (11) Press the Start Switch to recount the Latex Calibrator.  
Run the recount sequence and VR adjustment three times in total.
- (12) After the 4th analysis (recounting) is completed, press [1] key to continue the Latex analyses again.
- (13) Repeat the steps (7) through (11) above until the P-MFV falls into the acceptable range.
- (14) After the adjustment is completed, obtain three P-MFV results by analyzing or recounting Latex Calibrator.
- (15) Calculate the average of the three results and verify that the average falls within the acceptable range.
- (16) Press [3] key to exit the adjustment program.
- (17) Refit the Shield Cover No. 143 and the Top Cover.

## 4.2 HGB ADJUSTMENT

- (1) Verify that 30 minutes or more has been passed after the power ON.
- (2) Display the Status Display by pressing [SELECT] - [7] (Maintenance) - [5] (Status Display).

S		*Status Display*	
SEQ. NO.			12
PRESSURE			0.50
VACUUM			250
HGB CONVERT			2000
SENSOR	1 2 3 4 5 6 7 8		
SV	1 2 3 4 5 6 7 8 9 0		
	1 2 3 4 5 6 7 8 9 0		
	1 2 3 4		

Figure 4-7: Status Display

- (3) Adjust the VR1 on the PCB No. 2135 so that the HGB CONVERT value falls within the range  $2000 \pm 200$ .

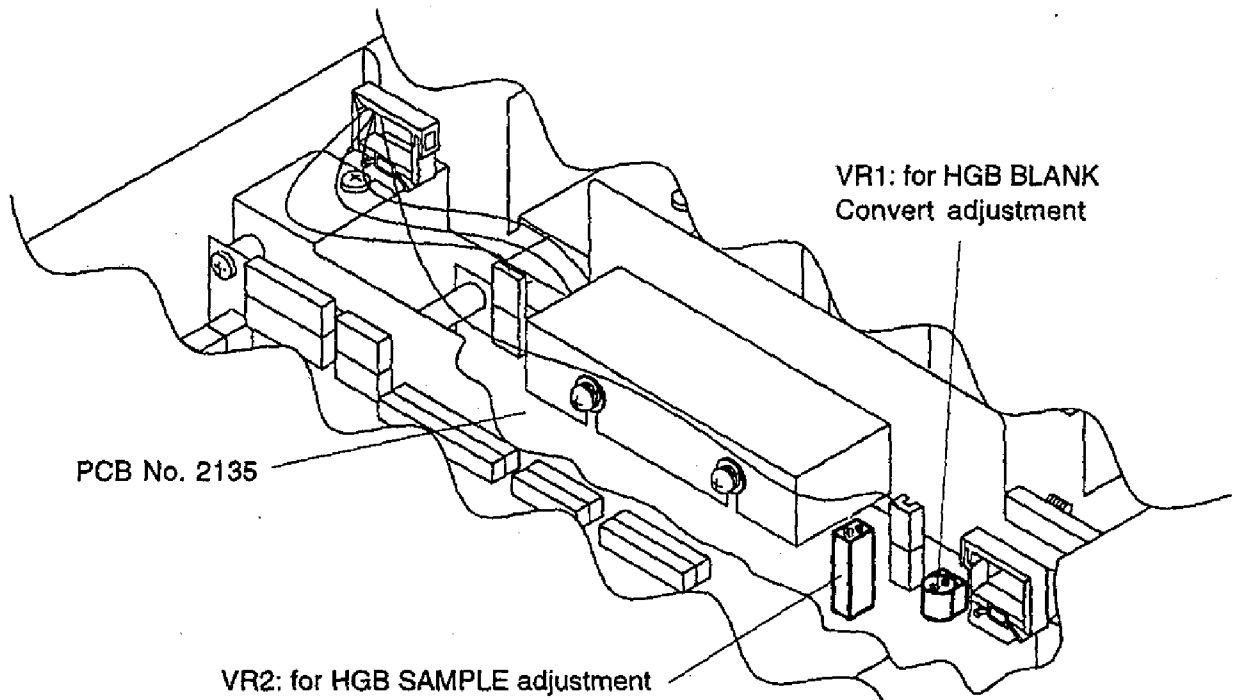

Figure 4-8: VRs for HGB Adjustment

- (4) Aspirate the fresh Sysmex control blood EIGHTCHECK (Normal Level).

- (5) Press [SELECT] key to stop the sequence at Sequence 7.

S		*Status Display*	
SEQ. NO.			7
PRESSURE			0.50
VACUUM			250
HGB CONVERT			14.2
SENSOR	1	2 3 4 5 6 7 8	
SV	1	2 3 4 5 6 7 8 9 0	
		1 2 3 4 5 6 7 8 9 0	
		1 2 3 4	

Figure 4-9: Sequence Stop at Sequence 7

- (6) Adjust the VR2 on the PCB No. 2135 so that the HGB CONVERT value falls within the following range:

$$\text{HGB CONVERT} = (\text{HGB Assay Value for EIGHTCHECK}) \pm 0.5 \text{ [g/dL]}$$

- (7) Press [SELECT] key to resume the sequence.



### 4.3 CLOG LEVEL ADJUSTMENT

- (1) Select 9. Service from Select Menu.
- (2) Select 2. Service Seq. from Service submenu, and select 7. Clog Adjustment. The Clog Adjustment screen appears.

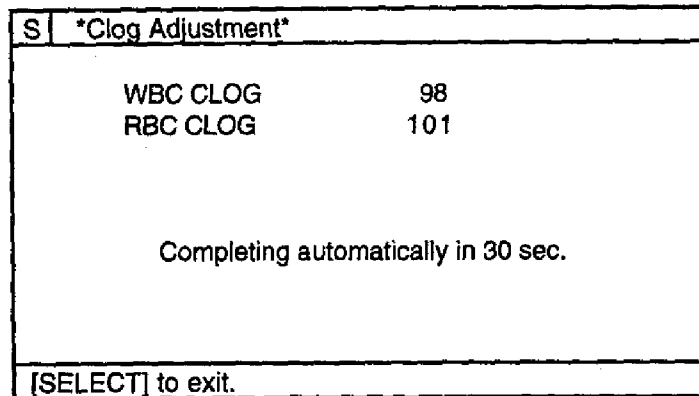

Figure 4-10: Clog Adjustment Screen

- (3) Adjust the VR6 on the PCB No. 2135 so that the WBC clog level falls within the range:  $100.0 \pm 1.0$ .
- (4) Adjust the VR7 on the PCB No. 2135 so that the RBC clog level falls within the range:  $100.0 \pm 1.0$ .

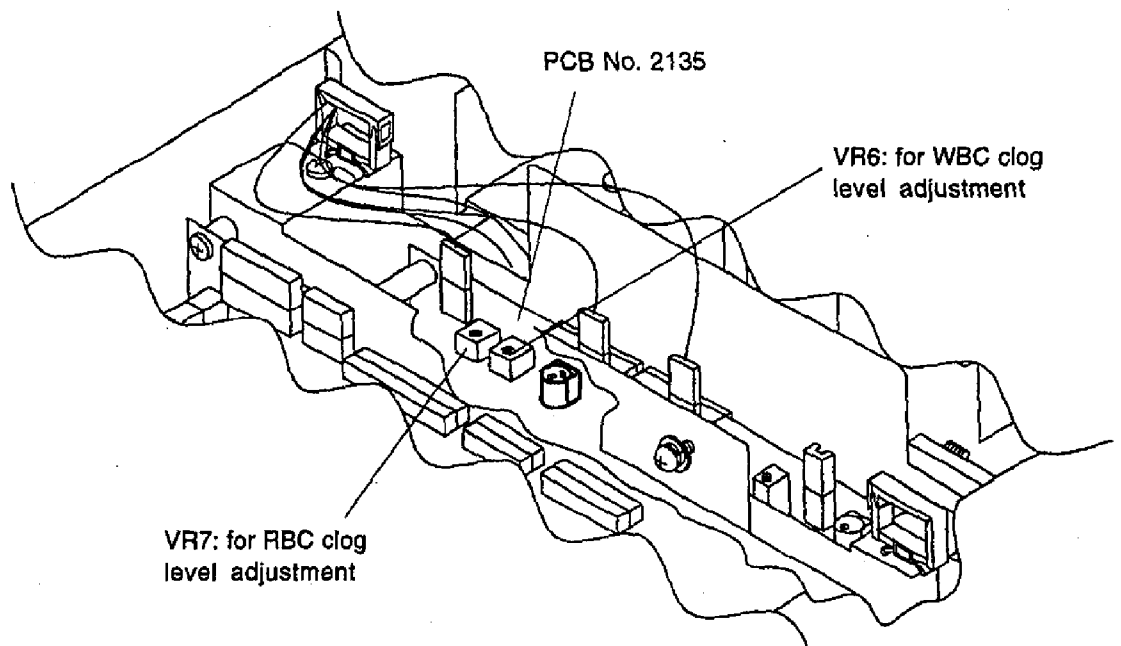

Figure 4-11: VRs for Clog Adjustment

- (5) The system returns to the Ready screen in 30 seconds.  
Or press [SELECT] key to return to the Ready screen.

**NOTE:** If the adjustment has not been completed when the system returns to Ready, access this program again.

## 4.4 PCB CHECKING AND ADJUSTMENT

### 4.4.1 PCB No. 2135 (Analog Main)

#### (1) HGB circuit adjustment

Adjustment VR	Test Point	Adjustment Item
VR6	TP18, TP50	Coarse BLANK adjustment
VR7	TP40, TP51	Coarse GAIN adjustment

#### (2) Reference voltage adjustment

Adjustment VR	Test Point	Set Value
VR8	TP17	4,100 mV $\pm$ 10 mV

#### (3) A/D START signal pulse width adjustment

Item	Adjustment VR	Test Point	Set Value
PLT	VR3	TP30	6 $\mu$ sec $\pm$ 10%
RBC	VR5	TP29	6 $\mu$ sec $\pm$ 10%
WBC	VR9	TP28	6 $\mu$ sec $\pm$ 10%

#### (4) Clog monitoring circuit adjustment

Adjustment VR	Test Point	Adjustment Item
VR12	TP21	RBC • PLT
VR10	TP22	WBC

#### (5) Sensitivity Adjustment

PCB No. 2135 uses digital VRs to adjust RBC and WBC sensitivity. PLT sensitivity is adjusted by a conventional variable VR.

#### (6) Test Points

TP8	WBC Sensitivity
TP9	RBC Sensitivity
TP10	PLT Sensitivity
TP11	GND (Analog)
TP12	WBC Clog Monitoring Signal
TP13	RBC Clog Monitoring Signal

**NOTE:** TP28, TP29 and TP30 are 1x1 mm test points.

#### 4.4.2 PCB No. 6363 (Main CPU)

##### (1) DIP Switch S1 Settings

Bit	Function	C-2 (117V)	C-3 (220V, Europe)	C-4 (240V)	C-5 (220V, China)
1	Memory initialization at start up (for factory use only) ON: Start up with memory initialization OFF: Usual start up	OFF	OFF	OFF	OFF
2	Built-in Printer ON: Connected OFF: Not connected	OFF	OFF	OFF	ON
3	Host Computer ON: Connected OFF: Not connected	OFF	OFF	OFF	<del>OFF</del> ON <span style="border: 1px solid black; padding: 2px;">A</span>
4	Quick system (production line use only) ON: Connected OFF: Not connected	OFF	OFF	OFF	OFF
5	Histogram display in Pre-diluted Mode ON: Display OFF: Not display	OFF	OFF	OFF	ON
6	Analysis results display when imitation reagent is detected. ON: Display analysis result with an asterisk (*) indicating unreliable data (Level 2) OFF: Not display the result (Level 1)	ON	ON	ON	ON
7	Clog monitoring in Auto Rinse ON: Monitor OFF: Do not monitor	ON	ON	ON	ON
8	(Not Used: Fixed to ON)	ON	ON	ON	ON

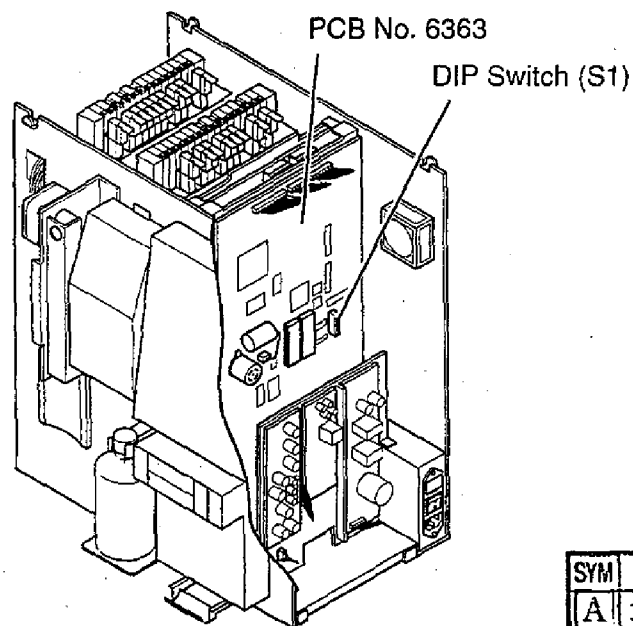

Figure 4-12: DIP SW Location

SYM	ECR NO.	SERIAL NO.
A	398E029	A1486-

(2) Test Points and Adjustments

Adj. VR	Test Point		Function & Adjustment	
None	TP1	TP3 (GND)	+5 V (digital):	+5.00 ± 0.25 V
None	TP2	TP3 (GND)	+12 V (digital):	+12.00 ± 0.60 V
None	TP4	TP6 (GND)	+15 V (analog):	+15.00 ± 0.75 V
None	TP5	TP6 (GND)	-15 V (analog):	-15.00 ± 0.75 V
VR1	TP7	TP6 (GND)	WBC A/D reference voltage:	+3.20 ± 0.10 V
VR1	TP8	TP6 (GND)	PLT A/D reference voltage:	+3.20 ± 0.10 V
VR2	TP9	TP6 (GND)	RBC A/D reference voltage:	+3.20 ± 0.10 V
None	TP10	TP3 (GND)	LCD Drive:	Approx. +30 V
VR*	TP11	TP3 (GND)	LCD Contrast Adjustment:	Approx. +21-27 V

**NOTE:** Adjustment volume for LCD contrast is located at the bottom of Panel Keyboard.  
Adjust RBC A/D reference voltage using VR2 just after the initial set up of D/A converter. (For example when the system becomes Ready after Power ON.)

(3) LEDs

LED	Descriptions	
D1	RUN:	Lights ON when Asb signal becomes effective. Flashes when a program is running.
D2	HALT	Lights ON when RESETb signal or HALPb signal is generated (1st-3rd pins of J16 are connected.) Also lights ON when 2nd-3rd pins of J16 are connected (ICE Connection Mode).

**NOTE:** When replacing PCB No. 6363, the factory settings must be changed. Refer to *Section 5.9.3 Factory Initialize* of this manual for the procedures.

4.4.3 PCB No. 4087 (Power Supply Unit)

1) PCB NO. 4087

Adjustment VR	Adjustment Voltage	Test Point
VR1	+100 VDC ± 3 V	J6 - 5 (GND) J6 - 6 (+100 VDC)

2) Switching Regulator VS50B-12

Adjustment VR	Adjustment Voltage	Test Point
VR1	+12 VDC ± 0.2 V	CN2 - 1,2 (GND) CN2 - 3,4 (+12 VDC)

3) Switching Regulator VS15B-5

Adjustment VR	Adjustment Voltage	Test Point
VR1	+5 VDC ± 0.1 V	CN2 - 1,2 (GND) CN2 - 3,4 (+5 VDC)

## 4.5 PROGRAM VERSION UP PROCEDURES

Parts required: New version ROM 1KX21 ASSY  
(P/N 973-3311-1: Set of 2 PROMs 1KX2F-01, 1KX2F-02)

- (1) Turn the power OFF, and disconnect the power cord.
- (2) Verify that reagent tubes and waste line tubes are connected properly.
- (3) Remove one each of the fixing screw on right and left sides of the instrument.
- (4) Open the front cover, and loosen one each of top cover fixing screw on both left and right sides.
- (5) Remove the top cover.
- (6) Find PROM 1KX2F-01 and PROM 1KX2F-02 on PCB No. 6363.

- (7) Replace these PROMs by the new version ones.  
Make sure that PROM 1KX2F-01 is on the left side, and PROM 1KX2F-02 is on the right. Also make sure that the notched side faces down.

- (8) Connect the power cord.
- (9) Power ON the instrument.  
(When starting up the instrument in Factory Maintenance mode, press the Start Switch when turning ON the power switch, and keep it pressing until a beep sounds.)

- (10) The new version number [00-XX] will be displayed on the "Sysmex KX-21" screen.
- (11) When the Power Fail error is alerted, press [1] key to continue.

- (12) If any maintenance instruction message is displayed, execute the required maintenance program.  
(Refer to the KX-21 Operator's Manual for procedures.)

**NOTE:** After the Factory Initialize program is executed, or the PCB No. 6363 is replaced, the maintenance instruction messages will be displayed at power ON. In these cases, press [3] key to proceed the start-up without performing maintenance.

- (13) When any setting change, initialization, verification is required, access the appropriate Service Program. Refer to Section 5 for the service programs.
- (14) Re-mount the top cover, and tighten the fixing screws.  
Be careful not to pinch tubes and wirings when mounting the cover.

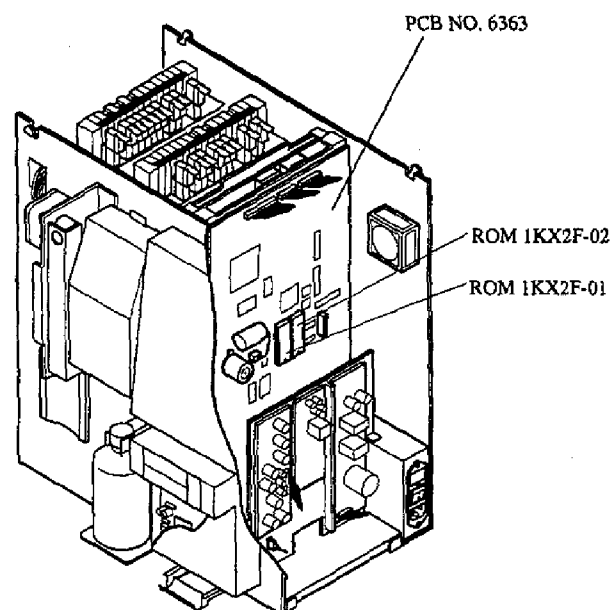
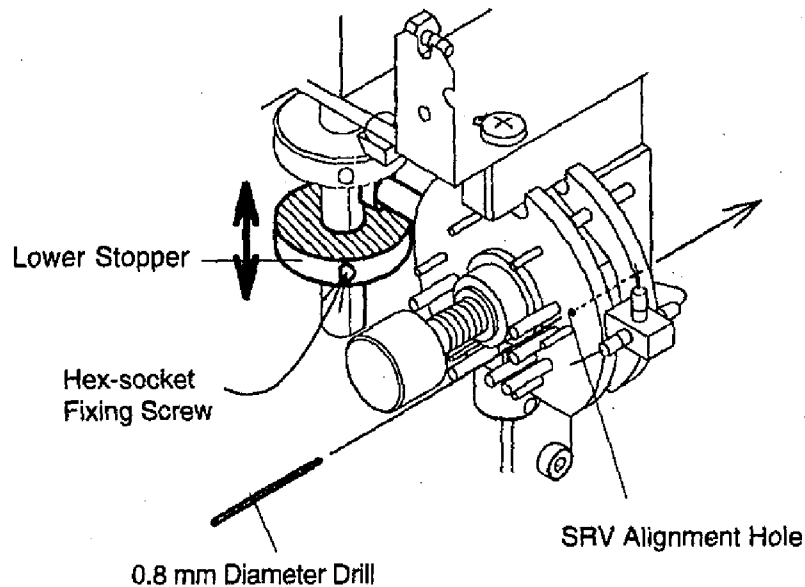

Figure 4-13: PROM Location

## 4.6 MECHANICAL PARTS ADJUSTMENT

### 4.6.1 SRV Position Adjustment

- (1) Enter the maintenance mode. (See 5.2 ENTERING MAINTENANCE MODE.)
- (2) Select SV Test Operation by pressing "Service" -> "4: Test Operation" -> "2: SV Test Operation". (See 5.7.2 SV Test Operation.)
- (3) Prepare a drill bit with 0.8 mm diameter. Verify that this drill bit can penetrate through SRV (3 pieces : SRV Fixed Valve(L), Rotor Valve and SRV Fixed Valve(R)) at the SRV alignment hole. If not, adjust the lower Stopper position by loosening a hex-socket fixing screw so that the drill bit will smoothly penetrate through the SRV.



**Figure 4-14:** SRV in home position

- (4) Rotate the SRV by entering SV No. 16 and ENTER.
- (5) Verify that this drill bit can penetrate through SRV (3 pieces : SRV Fixed Valve(L), Rotor Valve and SRV Fixed Valve(R)) at the SRV alignment hole. If not, adjust the lower Stopper position by loosening a hex-socket fixing screw so that the drill bit will smoothly penetrate through the SRV.

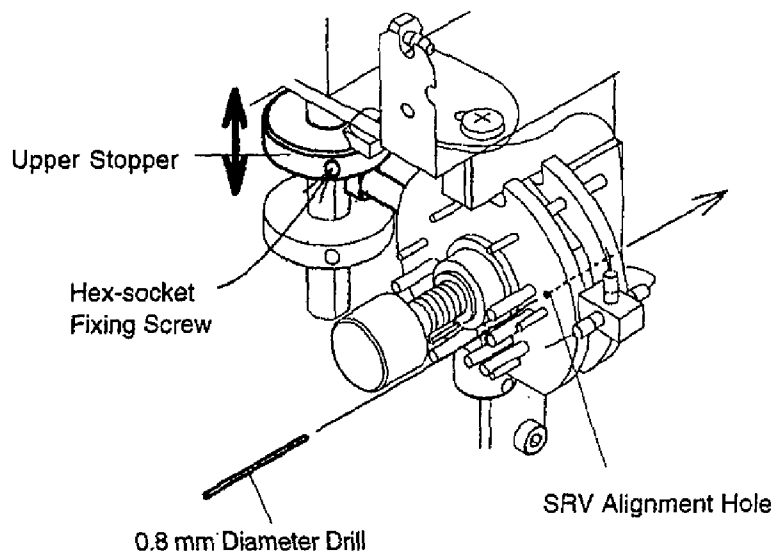
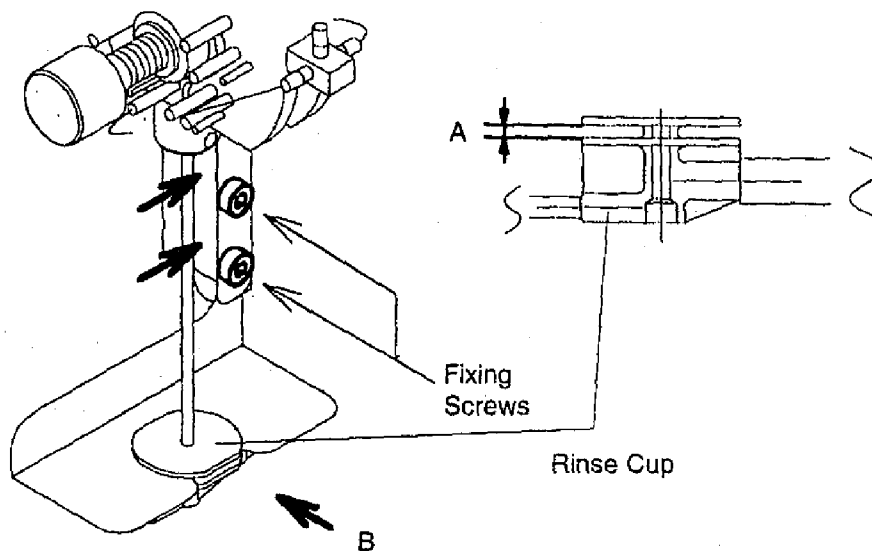

**Figure 4-15: SRV in Rotate Position**

- (6) Rotate the SRV to home position by pressing 16 and ENTER again.
- (7) Perform AUTO RINSE and verify that no background count error is reported after rinsing sequence is completed.
- (8) Perform QC and verify that the control blood data is acceptable.

#### 4.6.2 Rinse Cup Position Adjustment

- (1) Enter the maintenance mode. (See 5.2 ENTERING MAINTENANCE MODE.)
- (2) Press start key and wait until rinse cup descending lowest position.
- (3) Press SELECT key to stop the sequence.
- (4) Verify the pipette tip is placed in the gap "A". (View from "B" is easy to verify.)
- (5) If adjustment is necessary, adjust the Rinse Cup height by loosening two screws shown in figure so that the pipette tip will be between the gap "A".



**Figure 4-16: Rinse Cup Adjustment**

## SECTION 5 MAINTENANCE PROGRAMS

5.1	SPECIAL MODES.....	5-1
5.2	ENTERING THE MAINTENANCE MODES.....	5-1
5.2.1	Maintenance Mode.....	5-1
5.2.2	Factory Maintenance Mode.....	5-1
5.2.3	Access to Maintenance Modes.....	5-2
5.3	MENU CONFIGURATION.....	5-3
5.4	CLOG REMOVAL.....	5-4
5.5	SERVICE SEQUENCE.....	5-4
5.5.1	Setting Sequence.....	5-5
5.5.2	Deprime Sequence.....	5-5
5.5.3	Gain Adjustment.....	5-6
5.5.4	Control Mode.....	5-6
5.5.5	Calibrator Mode.....	5-6
5.5.6	Continuous Mode.....	5-7
5.5.7	Clog Adjustment (Clog Voltage Adjustment Sequence).....	5-7
5.6	SETTINGS.....	5-8
5.6.1	Initialize.....	5-8
5.6.2	Change.....	5-9
5.6.2.1	Calibration.....	5-10
5.6.2.2	Hardware Limit.....	5-11
5.6.2.3	Parameters (Other Settings).....	5-12
5.7	TEST OPERATION.....	5-13
5.7.1	DP Test Operation.....	5-13
5.7.2	SV Test Operation.....	5-14
5.7.3	HC Test Operation (Optional).....	5-14
5.7.4	IP (Internal Printer) Test Operation (Optional).....	5-14
5.8	SERVICE DATA.....	5-15
5.8.1	Status Display (Sensor & SV Status).....	5-16
5.9	SPECIAL SEQUENCE.....	5-17
5.9.1	Factory Rinse Sequence.....	5-17
5.9.2	Shipping Sequence.....	5-17
5.9.3	Factory Initialize.....	5-17
5.9.4	Factory Settings.....	5-19
5.9.5	Raw Data Output.....	5-19
5.9.6	Debugger.....	5-19
5.10	PRINT SETTINGS.....	5-19



## SECTION 5 MAINTENANCE PROGRAMS

### 5.1 SPECIAL MODES

The KX-21 program is provided with various types of special mode performing various functions. These are the following three modes, and this section explains only modes (2) and (3).

- (1) **Regular Mode**  
This mode is for the operator routine use. It is available when the instrument is powered up in the ordinal procedure.
- (2) **Maintenance Mode**  
This is for use by the Sysmex Service Field Representatives in carrying out maintenance of the instrument.
- (3) **Factory Maintenance Mode**  
This is for adjustment, pre-shipment inspection and shipment preparation of the instrument performed by the production staffs. Also some menu are used by R&D staffs for investigation purpose.

### 5.2 ENTERING THE MAINTENANCE MODES

Use the following procedure to enter into the Maintenance mode and Factory Maintenance mode.

#### 5.2.1 Maintenance Mode

- To enter the Maintenance mode;  
Press [C] [9] [.] and [0] keys on the Panel Keyboard in this order.

**S** is displayed in the left corner of top line of the LCD display.

- To exit from the Maintenance mode;  
Press [C] and [0] keys on the Panel Keyboard in this order.

**S** disappears and the system becomes the Regular mode.

#### 5.2.2 Factory Maintenance Mode

- To enter the Factory Maintenance mode;  
Press the Start Switch when turning ON the power switch, and keep it pressing until a beep sounds.

**D** is displayed in the left corner of top line of the LCD display.

- To exit from the Factory Maintenance mode;  
Press [C] and [0] keys on the Panel Keyboard, or  
Power OFF the instrument.

### 5.2.3 Access to Maintenance Modes

Press [SELECT] key on the Panel Keyboard.  
From the Select menu, select "9 Service" by pressing [9] key.  
The Service menu will appear.

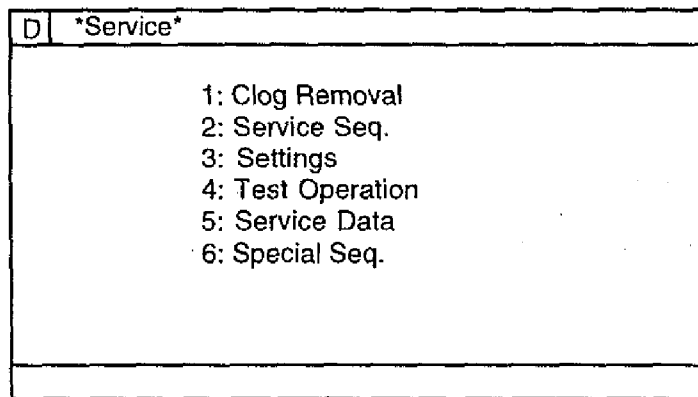

**Figure 5-1: Service Menu Display (in Factory Maintenance Mode)**

"\*Service\*" will appear in the system status area.  
Note that "6: Special Seq." menu appears only in the Factory Maintenance mode.  
Refer to the following sections for each menu.

### 5.3 MENU CONFIGURATION

Service	1: Clog Removal		
	2: Service Seq.	1: Setting Seq.	
		2: Deprime Seq.	
		3: Gain Adjustment	1: WBC/RBC
		4: Control Mode	2: PLT
		5: Calibrator Mode	
		6: Continuous Mode	
		7: Clog Adjustment	
	3: Settings	1: Initialize	1: Cycle Counter
			2: Calibration
			3: Stored Data
			4: QC Data
			5: Hardware Limit
			6: Others
		2: Change	1: Calibration
			2: Hardware Limit
		3: Print Settings	3: Parameters
	4: Test Operation	1: DP Test Operation	
		2: SV Test Operation	
		3: HC Output Test	
		4: IP Output Test	
	5: Service Data	1: Print	
	6: Special Seq.	1: Factory Rinse Seq.	
		2: Shipping Seq.	
		3: Factory Initialize	
		4: Factory Settings	
		5: Raw Data Output	
		6: Debugger	

## 5.4 CLOG REMOVAL

Apply voltage to the transducer apertures, and execute the clog removal sequence.

- (1) Select 9. Service from Select Menu.
- (2) Select 1. Clog Removal from Service submenu. The clog removal sequence starts.

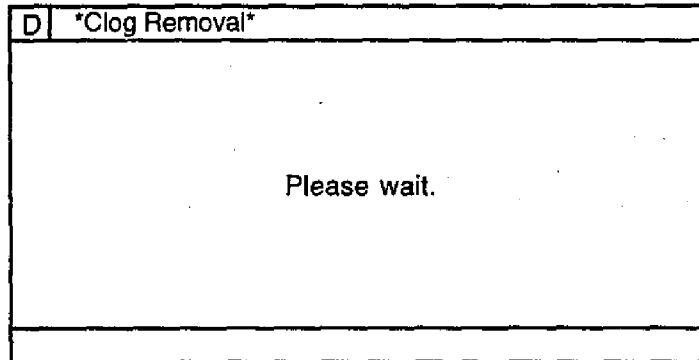

**Figure 5-2: Clog Removal in Progress**

- (3) After completion of the sequence, return to the Ready Screen.

## 5.5 SERVICE SEQUENCE

Service sequence include the following functions:

1. Setting sequence
2. Deprime sequence
3. Gain adjustment sequence
4. Control mode
5. Calibrator mode
6. Continuous mode
7. Clog adjustment (clog voltage adjustment sequence)

- (1) Select 9. Service from Select Menu.
- (2) Select 2. Service Seq. from Service submenu. The Service Sequence submenu appears.

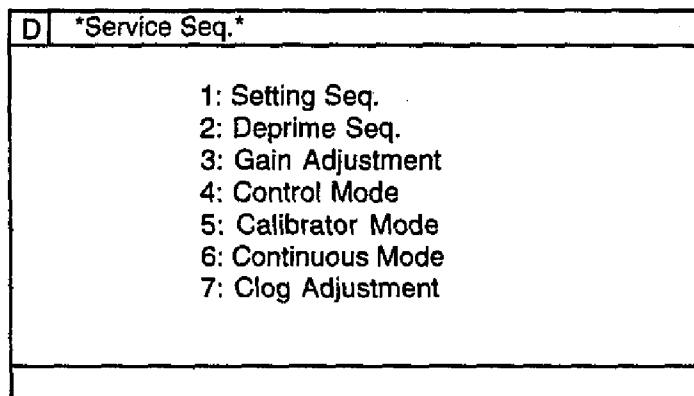

**Figure 5-3: Service Seq. Menu**

### 5.5.1 Setting Sequence

The setting sequence follows start-up when the system is installed.

- (1) From the Service Seq. menu, select 1: Setting Seq.  
"Press Start switch" message will be displayed.
- (2) Press the Start Switch to start the setting sequence.  
Press the [SELECT] key to cancel the program execution. The system will return to the Ready Screen.
- (3) When the sequence is in progress, "Please wait." is displayed and the progress status will appear in the system status area.  
Note that the sequence cannot be stopped after the sequence started.
- (4) When the sequence is completed, the system will return to the Ready Screen.

### 5.5.2 Deprime Sequence

During this sequence, liquid is discharged from the hydraulic lines.

- (1) From the Service Seq. menu, select 2: Deprime Seq.  
Instruction message will appear in the data processing area as shown in Figure 5-4.

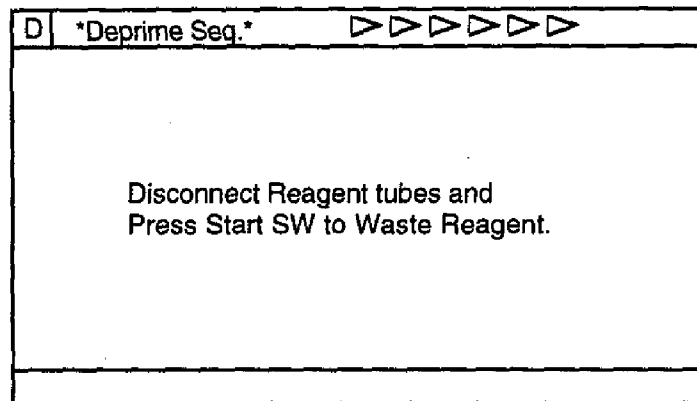

**Figure 5-4:** Deprime Sequence Screen

- (2) Press the Start Switch to start the deprime sequence. The liquid will be deprimed.  
Press the [SELECT] key to cancel the program execution. The system will return to the Ready Screen.
- (3) When the sequence is in progress, "Please wait." is displayed and the progress status will appear in the system status area.  
Note that the sequence cannot be stopped after the sequence started.
- (4) When the sequence is completed, the system will return to the Ready Screen.

### 5.5.3 Gain Adjustment

During this sequence, the WBC, RBC, and PLT gain (sensitivity) is adjusted. The WBC/RBC gain can be adjusted automatically by changing the resistance of the digital control (potention- meter) on the analog board (PCB No. 2135) using standard substances such as CELLCHECK-400.

The gain of PLT channel is adjusted by using the analog control volume.

- (1) From the Service Seq. menu, select 3: Gain Adjustment. The Gain Adjustment menu will appear.

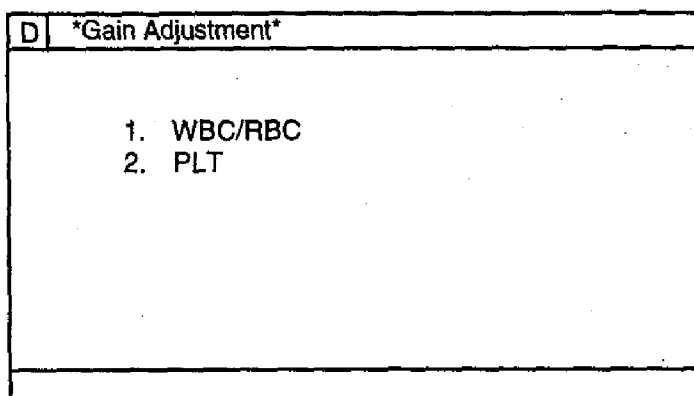

Figure 5-5: Gain Adjustment Menu

Refer to Section 4: Adjustment for the detail.

### 5.5.4 Control Mode

Switch the system to Control Mode (control blood analysis mode). In Control Mode, data analyses for control blood will be performed for normal analyses.

- (1) From the Service Seq. menu, select 4: Control Mode. In the system status area, "QC" will be displayed in reverse.

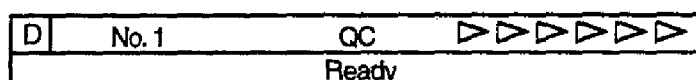

Figure 5-6: Control Mode

- (2) To exit from control mode, select 4: Control Mode from the Service Seq. menu again.

### 5.5.5 Calibrator Mode

Switch the system to Calibrator Mode (calibrator analysis mode). In Calibrator Mode, data analyses for calibrator will be performed for normal analyses.

- (1) From the Service Seq. menu, select 5: Calibrator Mode. In the system status area, "CL" will be displayed in reverse.

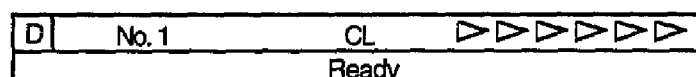

Figure 5-7: Calibrator Mode

- (2) To exit from control mode, select 5: Calibrator Mode from the Service Seq. menu again.

### 5.5.6 Continuous Mode

Switch the system to Continuous Mode (continuous analysis mode).

- (1) From the Service Seq. menu, select **6: Continuous Mode**.  
The analysis sequence will be repeated until the [SELECT] key is pressed.
- (2) Press the [SELECT] key to stop the sequence and the system will enter the Ready status.  
If an error that makes the analysis impossible occurs in continuous mode, the continuous sequence will stop.

### 5.5.7 Clog Adjustment (Clog Voltage Adjustment Sequence)

Adjust the voltage to detect the aperture clog.

- (1) From the Service Seq. menu, select **7: Clog Adjustment**.  
The Clog Adjustment screen will appear. The clog voltage will appear in real time on the screen.

D	*Clog Adjustment*	
	WBC CLOG	97
	RBC CLOG	97
	Completing automatically in 30 sec.	
	[SELECT] to exit.	

**Figure 5-8: Clog Adjustment Screen**

- (2) Adjust the voltage. Refer to Section 4: Adjustment for the procedures.
- (3) If you press the [SELECT] key, the Ready Screen will appear. Or after 30 seconds have passed, the Ready Screen will automatically appear.

## 5.6 SETTINGS

The Settings program is used to initialize, change and print out the service setting values using the following submenu:

1. Initialize
2. Change
3. Print Settings

- (1) Select 9. Service from Select Menu.
- (2) Select 3. Settings from Service submenu. The Settings submenu appears.

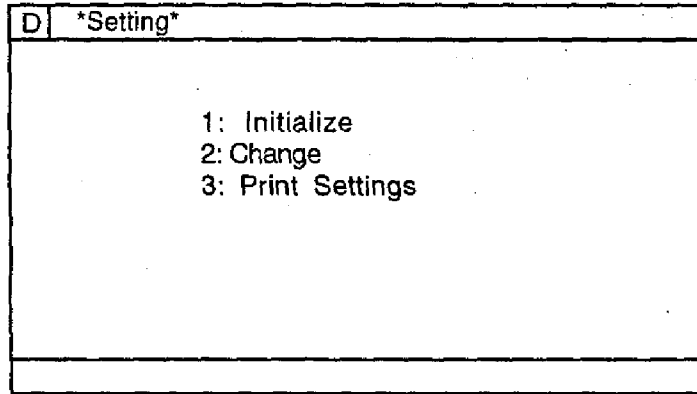

Figure 5-9: Settings Menu

### 5.6.1 Initialize

Initialize the system settings.

- (1) From the Settings menu, select 1: Initialize. The Initialize menu will appear.

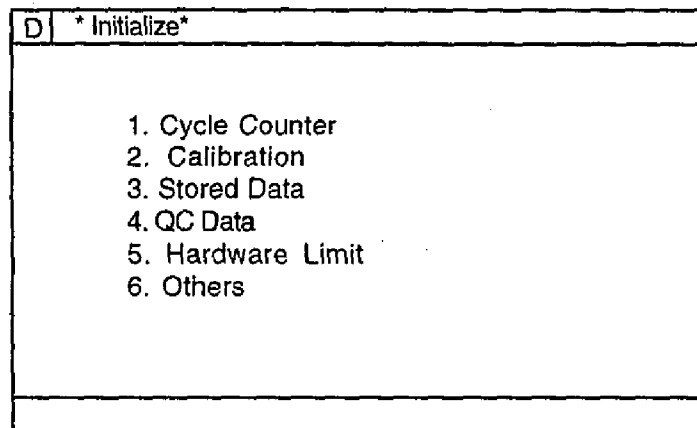

Figure 5-10: Initialize Menu



- (2) Using the [↑] and [↓] keys, select the item you wish to initialize, and press [ENTER] key. Or use the numeric keys to select item.

**Table 5-1: Initialize Item**

	Menu	Parameter to Initialize
1	Cycle Counter	Instrument total cycle count Unit operations: Waste Chamber, Detector, SRV
2	Calibration	Gain adjustment parameters Calibration values (service) Calibration values (user)
3	Stored Data	Stored data
4	QC Data	QC data QC settings
5	Hardware Limit	Hardware limits
6	Others	Mark Limits Output Settings

- (3) A confirmation message will appear in the menu display area.

Initialize. OK?	Yes	No
-----------------	-----	----

**Figure 5-11: Initialize Confirmation Message**

If you select [Yes], the settings will be initialized and the system will return to the Ready Screen. If you select [No], or press the [SELECT] key, the system will return to the Ready Screen without initializing.

### 5.6.2 Change

Change the system settings.

- (1) From the Settings menu, select 2: Change. The Change menu will appear.

D	* Change*
1. Calibration 2. Hardware Limit 3. Parameters	

**Figure 5-12: Change Menu**

- (2) Using the [↑] and [↓] keys, select the item you wish to change, and press [ENTER] key. Or use the numeric keys to select item.

### 5.6.2.1 Calibration

- (1) Using the [↑], [↓] and [ENTER] keys, move the cursor to the parameter you wish to change.
- (2) Using the numeric keys and decimal key, enter the calibration value. The acceptable range for each parameter is 0.0 to 999.9. If the input range is exceeded, an alarm will sound and the data entry is ignored. For each parameter, numerals that are not significant digits will be cut off. For example, if the WBC calibration is entered as 97.55, the set value will be 97.5.

[C] key functions as backspace to delete one character.

If a calibration value has already been entered, the previous value will be deleted upon any key entry.

D * Calibration*	
WBC	100.0
RBC	100.0
HGB	100.0
RBC GAIN	100.0
PLT	100.0
RDW-SD	100.0
RDW-CV	100.0
MPV	100.0
PDW	100.0
P-LCR	100.0

**Figure 5-13: Change Calibration Menu**

- (3) When the cursor is on the bottom line, pressing the [↓] key will change the displayed parameters.
- (4) If you press the [SELECT] key, the change confirmation message will appear in the menu display area.

Execute Settings?	Cont.	Set	Cancel
-------------------	-------	-----	--------

**Figure 5-14: Change Confirmation Message**

If you select [Cont.], you can continue to enter calibration values.

If you select [Set], the calibration value will be updated and the system will return to the Ready Screen.

If you select [Cancel] or press the [SELECT] key, the system will return to the Ready Screen without changing the settings.

The initial setting values will be as shown in the table below.

**Table 5-2: Calibration Initial Setting Values**

Parameter	Initial Value	Remarks
WBC-SENS	125	WBCch gain adjustment value
RBC-SENS	64	RBCch gain adjustment value
Others	100.0	

5.6.2.2 Hardware Limit

Use this program to change Hardware Limits.

- (1) Using the [↑], [↓] and [ENTER] keys, move the cursor to the item you wish to change.
- (2) Using the numeric keys and decimal key, enter the limit value.  
 For each parameter, numerals that are not significant digits will be cut off.  
 [C] key functions as backspace to delete one character.  
 If a limit value has already been entered, the previous value will be deleted upon any key entry.

D	* Hardware Limit*	
	PRESS SL	0.430
	PRESS SH	0.570
	PRESS ML	0.380
	PRESS MH	0.570
	PRESS RL	0.200
	PRESS RH	0.600
	VAC SL	230
	VAC SH	270
	VAC ML	100
	VAC MH	270

Figure 5-15: Change Hardware Limits Menu

- (3) When the cursor is on the bottom line, pressing the [↓] key will change the displayed parameters.
- (4) If you press the [SELECT] key, the change confirmation message will appear in the menu display area.

Execute Settings?	Cont.	Set	Cancel
-------------------	-------	-----	--------

Figure 5-16: Change Confirmation Message

If you select [Cont.], you can continue to enter limit values.  
 If you select [Set], the limit value will be updated and the system will return to the Ready Screen.  
 If you select [Cancel] or press the [SELECT] key, the system will return to the Ready Screen without changing the settings.

Table 5-3: Hardware Limits Initial Set Values

Parameter	Initial Value	Remarks
PRESS SL	0.430 (kg/cm <sup>2</sup> )	Pressure monitor lower limit (in Ready)
PRESS SH	0.570 (kg/cm <sup>2</sup> )	Pressure monitor upper limit (in Ready)
PRESS ML	0.380 (kg/cm <sup>2</sup> )	Pressure monitor lower limit (during analysis)
PRESS MH	0.570 (kg/cm <sup>2</sup> )	Pressure monitor upper limit (during analysis)
PRESS RL	0.300 (kg/cm <sup>2</sup> )	Pressure monitor lower limit (reserve)
PRESS RH	0.600 (kg/cm <sup>2</sup> )	Pressure monitor upper limit (reserve)
VAC SL	230 (mmHg)	Vacuum monitor lower limit (in Ready)
VAC SH	270 (mmHg)	Vacuum monitor upper limit (in Ready)
VAC ML	100 (mmHg)	Vacuum monitor lower limit (during analysis)
VAC MH	270 (mmHg)	Vacuum monitor upper limit (during analysis)
TEMP L	10.0 (°C)	Temperature monitor lower limit
TEMP H	40.0 (°C)	Temperature monitor upper limit

(Continued)

**Table 5-3: Hardware Limits Initial Set Values (Continued)**

Parameter	Initial Value	Remarks
RES L	70	Electric conductivity monitor lower limit
RES H	150	Electric conductivity monitor upper limit
BLNK W	0.3 (x10 <sup>5</sup> /uL)	WBC background limit
BLNK R	0.02 (x10 <sup>6</sup> /uL)	RBC background limit
BLNK P	10 (x10 <sup>3</sup> /uL)	PLT background limit
BLNK H	0.1 (g/dL)	HGB background limit
CLOG W	130	WBC clog monitoring level
CLOG R	130	RBC clog monitoring level
CMP TIMER	15 (minutes)	Pneumatic Unit stop time
WH LIMIT	95 (times)	Lysing reagent monitoring limit
<b>B</b> AG LIMIT	200	AG flag detection limit. Number of cells at WBC lower discriminator and the lower 2 channels.
<b>B</b> WL MSK	95 (%)	WBC count masking limit due to WL flag. The height of valley bottom at WBC lower discriminator is relatively given when the WBC histogram peak is assumed as 100%.

**5.6.2.3 Parameters (Other Settings)**

Use this program to set the use of Calibrator, and the report of PDW/P-LCR parameters.

- (1) Using the [↑], [↓] keys, move the cursor to the item you wish to change.
- (2) Pressing the [←], [→] keys alternates "Use" and "Not Use".

D *Parameters*	
Calibrator	Not Use
PDW, P-LCR	Use
QC ITEM	CBC8

**Figure 5-17: Change Hardware Limits Menu**

The initial values are shown in the table below.

**A Table 5-4-1: Parameters Initial Settings**

Parameter	Initial Value	Remarks
Calibrator	Not Use	Calibrator usage
PDW, P-LCR	Use	PDW, P-LCR display
QC ITEM	CBC8	QC parameters can be selected among CBC8, USA or ALL. See Table 5-4-2.

**A****Table 5-4-2: QC Parameters Settings**

Selected Parameters for QC	CBC8	USA	ALL
Number of parameter	8	17	21
CBC8	X	X	X
W-SCR	---	X	X
W-MCR	---	X	X
W-LCR	---	X	X
W-SCC	---	X	X
W-MCC	---	X	X
W-LCC	---	X	X
RDW-CV	---	X	X
RDW-SD	---	X	X
MPV	---	X	X
PDW	---	---	X
P-LCR	---	---	X
W-SMV	---	---	X
W-LMV	---	---	X

- (3) If you press the [SELECT] key, the change confirmation message will appear in the menu display area.

If you select [Cont.], you can continue settings.

If you select [Set], the setting will be updated and the system will return to the Ready Screen.

If you select [Cancel] or press the [SELECT] key, the system will return to the Ready Screen without changing the settings.

## 5.7 TEST OPERATION

The following test programs are available:

1. DP Test Operation
2. SV Test Operation
3. HC Output Test
4. IP Output Test

- (1) Select 9. Service from Select Menu.
- (2) Select 4. Test Operation from Service submenu. The Test Operation submenu appears.

D	*Test Operation*
	1: DP Test Operation
	2: SV Test Operation
	3: HC Output Test
	4: IP Output Test

**Figure 5-18: Test Operation Menu**

### 5.7.1 DP Test Operation

Diaphragm Pump operation is tested.

- (1) From the Test Operation submenu, select 1: DP Test Operation. "Press Start switch" message will be displayed.
- (2) Press the Start Switch to start the DP test sequence.
- (3) "Please wait" message is displayed during the sequence is in progress.
- (4) After the test sequence is completed, the Ready Screen is displayed.  
Or press [3] or [SELECT] key to stop the sequence.

### 5.7.2 SV Test Operation

Solenoid Valve single operation is tested.

- (1) From the Test Operation submenu, select **2: SV Test Operation**. The SV Test Screen will appear.

D * SV Test*					
1	O	11		21	
2		12	O	22	O
3		13	O	23	O
4		14		24	O
5		15			
6	O	16	O		
7		17			
8		18			
9		19			
10	O	20		SV No.	1

Figure 5-19: SV Test Screen

- (2) A circle (O) is displayed to the right of SV No. which is ON.  
Input the SV No. you want to test using numeric keys, and press [ENTER].  
Verify that ON/OFF is alternated for the selected SV.
- (3) Press [SELECT] key to return to the Ready Screen.  
The SV function will automatically reset to the status before tested.

### 5.7.3 HC Test Operation (Optional)

Send the dummy data for host communication test.

- (1) From the Test Operation submenu, select **3: HC Test Operation**.  
The test data will be sent to the host computer.
- (2) After the test data is output, Ready Screen will appear.

### 5.7.4 IP (Internal Printer) Test Operation (Optional)

Send the test characters to the built-in printer.

- (1) From the Test Operation submenu, select **4: IP Test Operation**.  
The built-in printer will print out the specified characters as shown in Figure 5-20.  
Verify that there is no missing character or dot.
- (2) After the test data is output, Ready Screen will appear.

```

a Q / 100 100 x 10 / L x L
ヤヨラソルレロワン° μ2046912X
タチツテトナニヌネノハヒフヘホマミムモ
カユヨッーアイウエオカキクケコサシスセソ
。 「 」 、 ・ 7 ァ イ ウ エ オ
Ü ä ö Ü ß à ° 5 é ù è " ò ì Ñ Ò Ñ Ë
P q r s t u v w x y z [ ] ^ _ ` ~ ¡ ¢ £ ¤
\ ] ^ _ ` ~ ¡ ¢ £ ¤ ¥ ¦ § ¨ © ª « ¬ ® ¯
H I J K L M N O P Q R S T U V W X Y Z [
4 5 6 7 8 9 : ; < = > ? @ A B C D E F G
! " # $ % & ' ( ) * + , - . / 0 1 2 3
    
```

Figure 5-20: Built-in Printer Test Print

## 5.8 SERVICE DATA

Displays and prints out the Service Data.

- (1) Select 9. Service from Select Menu.
- (2) Select 5. Service Data from Service submenu. The Service Data Screen as shown in Figure 5-21 appears.

D		* Service Data*		WB	▷▷▷▷▷▷▷▷	
Ready						
No. 1	WB				01/30	12: 34
HGB (BLNK, SAMP)		2316			2313	
CLOG (W, R)		98			101	
TEMP		25.6				
RDW (CV, SD)		0.0			0.0	
W-SMV, W-LMV		0.0			101.2	
W-MFV		0.0				
R-MFV		0.0				
P-MFV		0.0				
1: Print						

**Figure 5-21: Service Data Screen -1**

- (3) There are 4 screens of Service Data. Pressing the [←], [→] keys change the displayed screens.

On Service Data Screen -1, following items are displayed:

- HGB convert values (BLANK and SAMPLE)
- Clog monitoring voltage (WBC, RBC)
- Temperature
- Sensitivity parameters (W-MFV, R-MFV, P-MFV)

On the other three screens, WBC Sampling Data, RBC Sampling Data and PLT Sampling Data are displayed respectively. Analysis is possible with the Sampling Data displayed on LCD.

D		* Service Data*		WB	▷▷▷▷▷▷▷▷	
Ready						
No. 1	WB				01/30	12: 34
WBC	0	3	3			
	2	6	14			
	3	5	3			
	6	3	4			
	6	3	7			
	3	5	12			
	5	6	9			
	4	2	16			
	2	2	17		TOTAL	155
	3	1			RATIO	12
1: Print						

**Figure 5-22: Service Data Screen -2 (WBC Sampling Data)**

- (4) If the built-in printer is used, the Service Data can be printed out. Press [1] key to print. If the printing paper runs out or an error occurs during printing, printing will stop and the printer buffer will be cleared.  
Note that Cycle Counter is also printed out as Service Data.

### 5.8.1 Status Display (Sensor & SV Status)

The real-time ON/OFF status of sensors and solenoid valves can be displayed on Status Display screen.

- (1) Select 7. Maintenance from Select Menu.
- (2) Select 5. Status Display from Maintenance submenu. The Status Display screen appears.

* Status*		WB >>>>>>>>									
		Ready									
SEQ.NO.										12	
PRESSURE										0.52	
VACUUM										240	
HGB CONVERT										550	
SENSOR		1	2	3	4	5	6	7			
SV		1	2	3	4	5	6	7	8	9	0
		1	2	3	4	5	6	7	8	9	0
		1	2	3	4						
Change screen with <  or >											

Figure 5-23: Status Display Screen -1

#### <Sensor Status>

The displayed sensor status are shown in the table below.

Table 5-5: Sensor Status

No.	Monitored Sensor	Status when REVERSED
1	Waste Chamber Float SW	No liquid (float switch positions at lower end)
2	Diluent Chamber Float SW	No liquid (float switch positions at lower end)
3	(Not Used)	
4	Rinse Cup Limit SW	Limit SW is ON (positions at lower end)
5	Start SW	Start Switch is ON
6	(Not Used)	
7	Lyse Reagent Float SW	Lyse Reagent is connected. (Float SW connector is connected)

#### <SV Status>

The displayed SV status are shown in the table below.

The numbers 1 through 0 on the three line correspond to each SV as below.

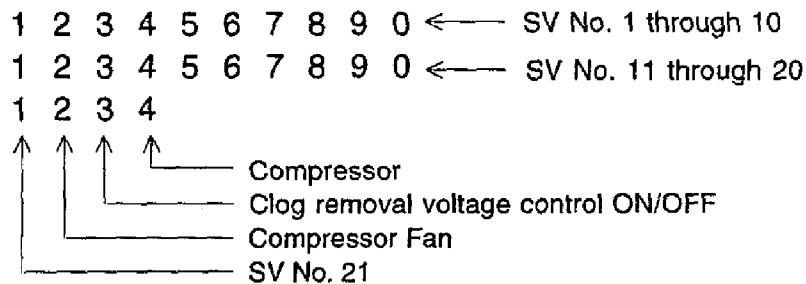



## 5.9 SPECIAL SEQUENCE

Special sequence is provided for the production and R&D use, including the submenu shown in Figure 5-23. This program can be accessed when the instrument is in the Factory Maintenance mode only.

- (1) Select 9. Service from Select Menu.
- (2) Select 6. Special Seq. from Service submenu. The Special Sequence submenu appears.

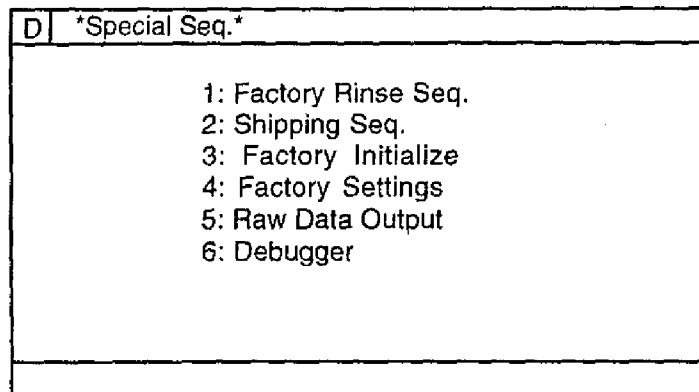

Figure 5-24: Special Seq. Menu

### 5.9.1 Factory Rinse Sequence

Rinse the hydraulic lines using special tools, SCAT, alcohol, PVA and CELLPACK.

### 5.9.2 Shipping Sequence

Rinse the hydraulic lines using special tools, CELLCLEAN and RO water before shipment.

### 5.9.3 Factory Initialize

Initialize setting values except CALIBRATION.

When this program is executed, the data stored in BBURAM are also initialized.

The system settings are reset to Japanese settings. To change the display language, follow the steps below.

- (1) Start up the instrument in Factory Maintenance mode. The screen as shown below will be displayed for a second. The program version number is displayed on this screen as [00-XX].

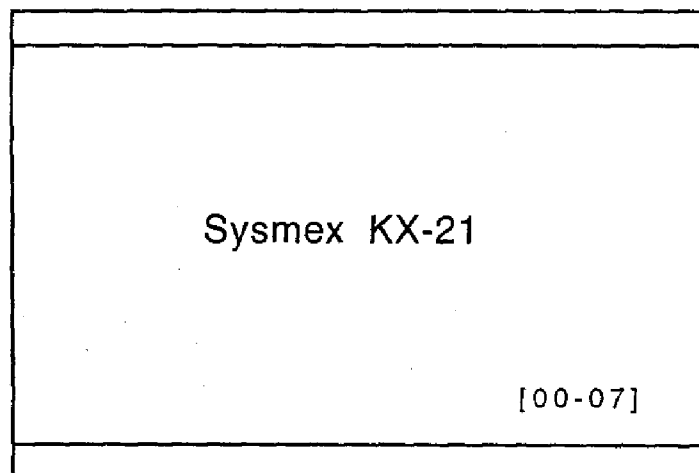

Figure 5-25: Sysmex Screen

- (2) If power fail error occurred or shutdown sequence was properly executed when powered OFF, the screen as shown below will be displayed.

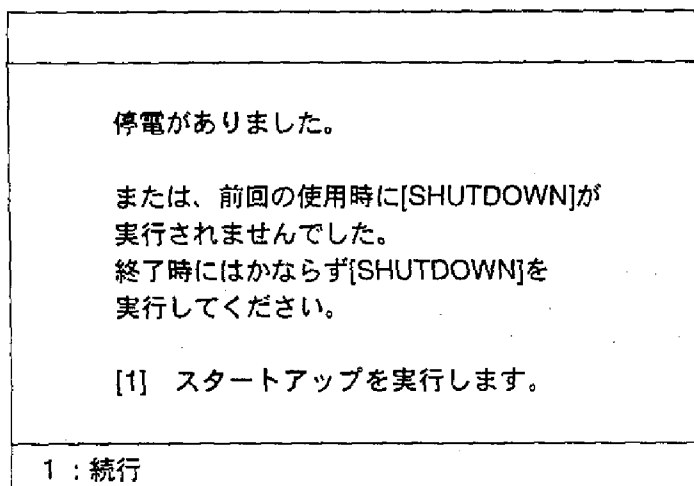

Figure 5-26: Power Fail Error Messages

- (3) Press [1] key to continue start-up sequence. The message as below will be displayed until the Ready Screen appears.

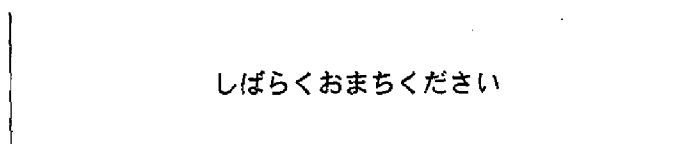

Figure 5-27: Message before Ready

- (4) The maintenance instruction message screens as shown below may appear.

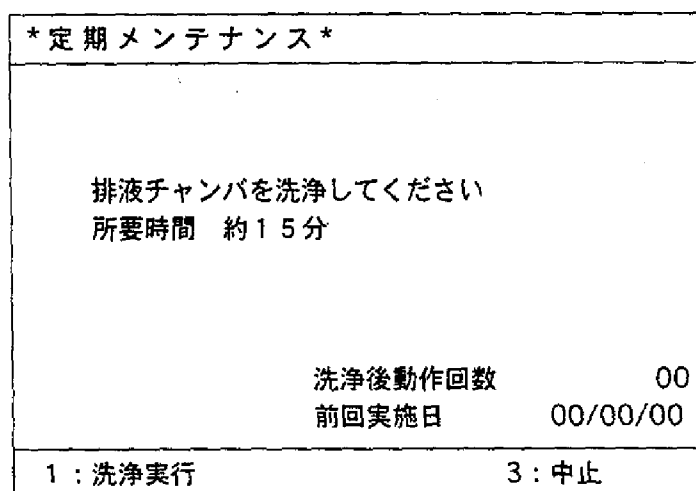

Figure 5-28: Example of Maintenance Instruction Screen

- (5) Press [3] key to cancel. When the instrument becomes Ready, the message as below will be displayed.

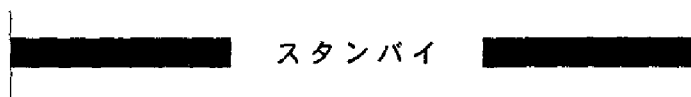

Figure 5-29: Ready Message in Japanese

- (6) Select 9. Service from Select Menu.
- (7) Select 6. Special Seq. from Service submenu. The Special Sequence submenu appears.
- (8) Select 4. Factory Settings from submenu. Refer to Section 5.9.4 below for the settings.

**NOTE:** After the Factory Initialize program is executed, the maintenance instruction messages may be displayed at power ON. Press [3] key to proceed the start-up, and set the current date/time, then reset the cycle counter. Refer to Section 5.6.1 to reset the counter.

#### 5.9.4 Factory Settings

Set up the system automatically depending on the requirement of each shipping destination (USA, Europe, China, Japan). The display language, units, parameters, etc. for the selected market are set up.

- (1) Select 9. Service from Select Menu.
- (2) Select 6. Special Seq. - 4. Factory Settings from submenu. The screen as below will appear.

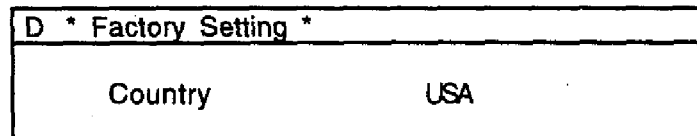

**Figure 5-30:** Factory Settings Screen

- (3) Press [▶]key to select the desired setting.
  - Japan: For Japanese market (Japanese)
  - USA: For American market (English)
  - Europe: For European and Asian Pacific market (English)
  - China: For Chinese market (Chinese)
- (4) Press [SELECT] and select "Set" and press [ENTER].  
The built-in printer prints out the setting values and returns to the Ready screen.

#### 5.9.5 Raw Data Output

Outputs raw data which has not been calibrated with coincidence error compensation.

#### 5.9.6 Debugger

Checks the computer-related functions for debugging purpose.

### 5.10 PRINT SETTINGS

All settings made in the Service programs will be printed to the built-in printer.

- (1) Select 9. Service from Select Menu.
- (2) Select 3. Settings from Service submenu. The Settings submenu appears.
- (3) From the Settings menu, select 3: Print Settings.

This is only effective if the built-in printer is connected.

If the printing paper runs out or an error occurs during printing, printing will stop and the printer buffer will be cleared.

## SECTION 6 ERROR MESSAGE and TROUBLESHOOTING

6.1	Introduction .....	6 - 1
6.1.1	[HELP] Key Function.....	6 - 1
6.1.2	Action Message Screen.....	6 - 3
6.1.3	Error Code Function.....	6 - 3
6.2	Sensor Location .....	6 - 4
6.3.	Error Message .....	6 - 5
6.3.1	Pressure.....	6 - 5
6.3.1.1	Pressure/Vac Error [0.5 kg/cm <sup>2</sup> Pressure Error] .....	6 - 5
6.3.1.2	Pressure/Vac Error [250 mmHg Vacuum Error].....	6 - 6
6.3.1.3	Pressure/Vac Error [Pressure Lower Error].....	6 - 8
6.3.2	Chamber.....	6 - 10
6.3.2.1	Waste Not Draining.....	6 - 10
6.3.2.2	Replenish Diluent.....	6 - 12
6.3.2.3	Replenish Lyse.....	6 - 14
6.3.3	Built-in Printer .....	6 - 16
6.3.3.1	No Printer Paper.....	6 - 16
6.3.3.2	Printer Error .....	6 - 18
6.3.4	Motor .....	6 - 20
6.3.4.1	Rinse Motor Error [Rinse Motor Function Error].....	6 - 20
6.3.5	Temperature.....	6 - 22
6.3.6.1	Room Temp. High .....	6 - 22
6.3.6.2	Room Temp. Low.....	6 - 22
6.3.6	Analysis .....	6 - 24
6.3.6.1	Background Error.....	6 - 24
6.3.6.2	Sampling Error [RBC Sampling Error].....	6 - 26
6.3.6.3	Sampling Error [PLT Sampling Error].....	6 - 26
6.3.6.4	Sampling Error [WBC Sampling Error].....	6 - 26
6.3.6.5	Sampling Error [RBC CCSD Noise Error] .....	6 - 28
6.3.6.6	Sampling Error [PLT CCSD Noise Error].....	6 - 28
6.3.6.7	Sampling Error [WBC CCSD Noise Error].....	6 - 28
6.3.6.8	HGB Error .....	6 - 30
6.3.6.9	WBC Aperture Clog.....	6 - 32
6.3.6.10	RBC Aperture Clog.....	6 - 32
6.3.6.11	Analysis Error [WBC/HGB Error (Tri-modal Particle)].....	6 - 34
6.3.6.12	Analysis Error [Detect Sensitivity Error (Electrical Conductivity)].....	6 - 36
6.3.7	Memory .....	6 - 38
6.3.7.1	Memory Error [RAM Error] .....	6 - 38
6.3.7.2	Memory Error [ROM Error].....	6 - 38
6.3.7.3	Setup Data Error.....	6 - 40
6.2.7.4	Print Error .....	6 - 42
6.3.8	External Output.....	6 - 44
6.3.8.1	HOST Comm. Error.....	6 - 44

6.3.9	QC .....	6 - 46
6.3.9.1	QC Error [L-J Control Error] .....	6 - 46
6.3.9.2	QC Error [ X Control Error] .....	6 - 46
6.3.9.3	Calibration Error.....	6 - 48
6.3.10	Maintenance.....	6 - 50
6.3.10.1	Clean SRV.....	6 - 50
6.3.10.2	Clean W. Chamber (Clean Waste Chamber).....	6 - 52
6.3.10.3	Clean Transducer.....	6 - 54

## Alphabetical List of Error Message

0.5 kg/cm2 Press. Err.....	6 - 5
250 mmHg Vacuum Error.....	6 - 5
<b>[A]</b>	
Analysis.....	6 - 24
<b>[B]</b>	
Background Error.....	6 - 24
Built-in Printer.....	6 - 16
<b>[C]</b>	
Calibration Error.....	6 - 48
Chamber.....	6 - 10
Clean SRV.....	6 - 50
Clean Transducer.....	6 - 54
Clean W. Chamber (Clean Waste Chamber.).....	6 - 52
<b>[D]</b>	
Detect Sensitivity Error (Electrical Conductivity).....	6 - 36
<b>[E]</b>	
External Output.....	6 - 44
<b>[H]</b>	
HGB Error.....	6 - 30
HOST Comm. Error.....	6 - 44
<b>[L]</b>	
L-J Control Error.....	6 - 46
<b>[M]</b>	
Maintenance.....	6 - 50
Memory.....	6 - 38
Motor.....	6 - 20
<b>[N]</b>	
No Printer Paper.....	6 - 16
<b>[P]</b>	
PLT CCSD Noise Error.....	6 - 28
PLT Sampling Error.....	6 - 26
Pressure.....	6 - 5
Pressure Lower Error.....	6 - 8
Print Error.....	6 - 42
Printer Error.....	6 - 18
<b>[Q]</b>	
QC/Calibration Error.....	6 - 46

<b>[R]</b>	
RAM Error.....	6 - 38
RBC Aperture Clog.....	6 - 32
RBC CCSD Noise Error.....	6 - 28
RBC Sampling Error.....	6 - 26
Replenish Diluent.....	6 - 12
Replenish Lyse.....	6 - 14
Rinse Motor Function Error.....	6 - 20
ROM Error.....	6 - 38
Room Temp. High.....	6 - 22
Room Temp. Low.....	6 - 22

<b>[S]</b>	
Setup Data Error.....	6 - 40

<b>[T]</b>	
Temperature.....	6 - 22

<b>[W]</b>	
Waste Not Draining.....	6 - 10
WBC Aperture Clog.....	6 - 32
WBC CCSD Noise Error.....	6 - 28
WBC Sampling Error.....	6 - 26
WBC/HGB Error (Tri-modal Particle).....	6 - 34

<b>[X]</b>	
X Control Error.....	6 - 46

## 6.1. Introduction

### 6.1.1 [HELP] Key Function

When a trouble has occurred, the warning alarm sounds and an error message is displayed on the screen. By pressing [HELP] key on the panel keyboard, you can stop the alarm and change over to the HELP screen that shows what action to take against the error.

Supplementary explanation for that function is given here.

If any judgment is required when the automatic recovery is to be performed, an action message is displayed to wait for the entry.

In the event multiple errors occur at the same time, press [HELP] key. The errors that have occurred are listed in the order from higher priority.

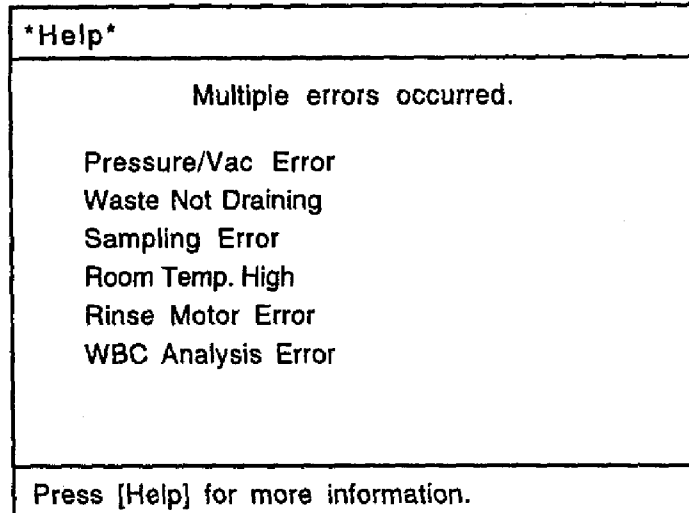

Figure 6-1-1: HELP Screen (Error List)

Press [HELP] key again. The screen changes to the HELP screen for the error listed at top.

- NOTE:**
- Pressing [C] key when any error occurs performs only the alarm reset.
  - When any error occurs, the error message is displayed on the screen, and pressing [HELP] key performs the automatic recovery or the action message display.



As for 1., 2. and 3. of the high priority order list described in the Table 6-1-1, HELP screen is displayed without pressing [HELP] key. If there are multiple errors when exit from HELP screen, the error list is displayed.

**Table 6-1-1: Error Priority (Analysis)**

Priority	Error Description	KX-21's Action
1	RAM Error	Operation disabled
	ROM Error	
	Setup Data Error	
2	Pressure Lower Error	Sequence suspended
3	WBC Analysis Error	Confirmation message
	RBC Analysis Error	
4	QC Error	
5	Print Error	Output function disabled partially
	Printer Error	
	No Printer Paper	
	Host Comm. Error	
6	0.5 kg/cm <sup>2</sup> Pressure Error	Analysis disabled
	250 mmHg Vacuum Error	
	Rinse Motor Function Error	Menu operation available
	Waste Not Draining	
	Replenish Diluent	
	Replenish Lyse	
7	HGB Error	becomes READY, however, bad effect on the next sample
	WBC CCSD Noise Error	
	RBC CCSD Noise Error	
	PLT CCSD Noise Error	
8	WBC Aperture Clog	becomes READY
	RBC Aperture Clog	
	Temperature High	no bad effect on the next sample
	Temperature Low	
	WBC Sampling Error	
	RBC Sampling Error	
	PLT Sampling Error	
	Background Error	

**NOTE:**

- Errors are divided into eight groups with the priority of 1 ~ 8 (high to low).
- The errors in each group are lined up from the one with the highest priority.

**Table 6-1-2: Error Priority (Others)**

1	Clean SRV	Maintenance message
2	Clean Waste Chamber	(only at start-up)
3	Clean Transducer	
-	Calibration Error	(only at calibration)

## 6.1.2 Action Message Screen

On the [Action Message] display screen, error code is displayed at the right end of the second line from the bottom of the screen.

On the [Action Message] display screen waiting for the key entry, pressing [select] key to stop the error recovery process and return to the ordinary screen (with the error status remained).

## 6.1.3 Error Code Function

Purpose: For service person to obtain the instrument status correctly over the phone.

**Table 6-1-3: Error Codes**

No.	Error	Error Description	Error Code	XXXXX	ZZZZ
11	Pressure				
	111	0.5 kg/cm <sup>2</sup> Pressure Error	11105.XXXXX.ZZZZ	Pressure Value	Sequence No.
	112	250 mmHg Vacuum Error	11225.XXXXX.ZZZZ	Vacuum Value	Sequence No.
	119	Pressure Lower Error	11901.XXXXX.ZZZZ	Pressure Value	Sequence No.
12	Chamber				
	129	Waste Not Draining	12900.0.0	0	0
	121	Replenish Diluent	12100.0.0	0	0
	124	Replenish Lyse	12490.0.0	0	0
34	Built-in Printer				
	345	No Printer Paper	34502.0.0	0	0
	345	Printer Error	34501.0.0	0	0
13	Motor				
	131	Rinse Motor Function Error	13150.0.0	0	0
21	Temperature				
	212	Room Temp. High	21251.XXXXX.0	Temperature	0
	212	Room Temp. Low	21252.XXXXX.0	Temperature	0
22	Analysis				
	221	WBC Aperture Clog	22104.XXXXX.0	Count time or Clog	0
	221	RBC Aperture Clog	22109.XXXXX.0	Count time or Clog	0
	229	Background Error	22910.XXXXX.ZZZZ	Background Value	Parameter (2)
	223	WBC Sampling Error	22301.0.0	0	0
	223	RBC Sampling Error	22302.0.0	0	0
	223	PLT Sampling Error	22303.0.0	0	0
	222	WBC CCSD Noise Error	22201.0.0	0	0
	222	RBC CCSD Noise Error	22202.0.0	0	0
	222	PLT CCSD Noise Error	22203.0.0	0	0
	225	HGB Error	22501.XXXXX.ZZZZ	HGB Background Value	HGB Sample Value
	226	WBC Analysis Error	22605.0.0	0	0
	226	RBC Analysis Error	22606.XXXXX.0	Conductivity	0
32	Memory				
	321	RAM Error	32105.0.0	0	0
	321	ROM Error	32101.0.0	0	0
	321	Setup Data Error	32106.XXXXX.0	Block Area	0
	323	Print Error	32301.0.0	0	0

No.	Error	Error Message	Error Code	XXXXX	ZZZZZ
33	External Output				
	331	HOST Comm. Error (Offline)	33102.0.0	0	0
	331	HOST Comm. Error (Time Out)	33103.0.0	0	0
	331	HOST Comm. Error (NAK Retry)	33106.0.0	0	0
41	QC				
	411	L-J Control Error	41101.0.0	0	0
	412	X Control Error	41201.0.0	0	0
	418	Calibration Error	41801.0.0	0	0

AAAAA. XXXXX. ZZZZZ

A: Error Code (Phenomenon)

X: Value 1

Z: Value 2

\* X and Z have different meanings depending on the error code.

## 6.2 Sensor Location

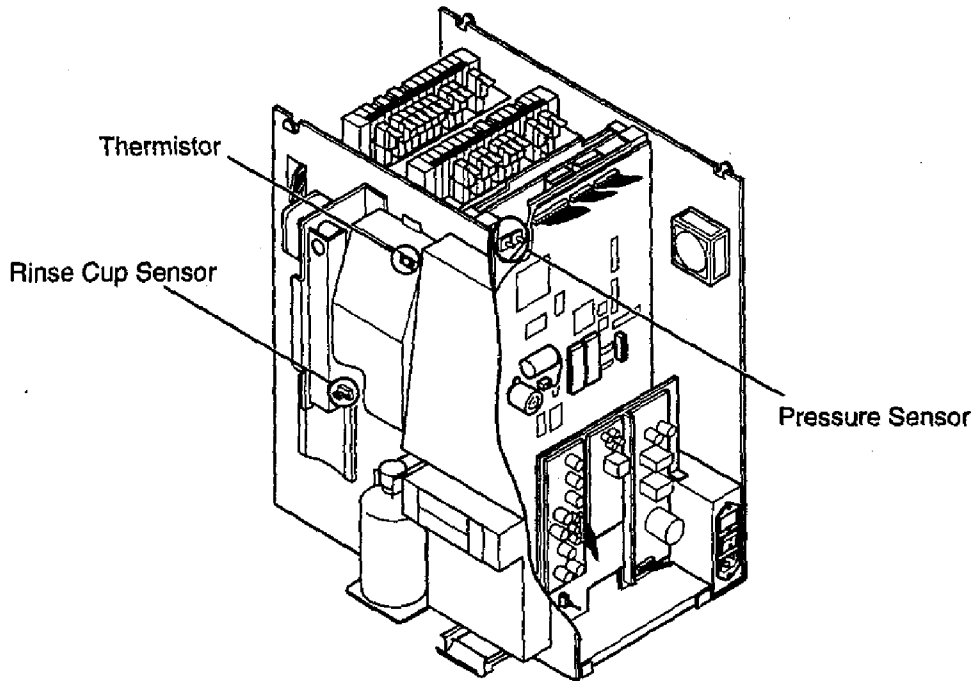

## 6.3. Error Message

### 6.3.1 Pressure

#### 6.3.1.1 Pressure/Vac Error [0.5 kg/cm<sup>2</sup> Pressure Error]

- Description : 0.5 kg/cm<sup>2</sup> pressure is outside the operating range.
- Function : The system secures the drain operation from the waste chamber and diaphragm pumps (DP) and the mixing operation in the transducer chambers and Hgb flow cell.
- Check method : A/D converter converts the voltage of the 0.5 kg/cm<sup>2</sup> pressure sensor which is connected to the 0.5 kg regulator. The instrument system checks if the pressure is within the following range.
- In the Ready mode : System monitors pressure at a constant timing (every 200 ms).  
Allowable range: From 0.4 to 0.6 (kg/cm<sup>2</sup>)  
System assumes to be an error when pressure deviates from the allowable range for more than 1.2 seconds continuously.
- During analysis : Whole Blood (WB) Mode  
At 3.0 sec. after start of sequence 1 (WBC DP dispense - HGB background convert sample dispense)  
At start of sequence 3 (RBC DP dispense - 1st dilution)  
At 3.0 sec. after start of sequence 4 (Lyse Reagent DP/WBC DP dispense)  
At start of sequence 5 (RBC DP dispense - 2nd dilution)  
Pre-Diluted (PD) Mode  
At 3.0 sec. after start of sequence 1 (WBC DP dispense - HGB background convert sample dispense)  
At start of sequence 3 (RBC DP dispense - WB mode rinse)  
At start of sequence 5 (RBC DP dispense - Lyse Reagent DP/WBC DP dispense)  
Allowable range: From 0.3 to 0.6 (kg/cm<sup>2</sup>)  
System assumes to be an error when pressure deviates from the allowable range at the specified timing.
- KX-21's action : (1) During analysis, the alarm sounds and the error message appears in the LCD after the sequence for aspirated sample has completed and the data is output (all data becomes ""). If pressure returns to the normal range after [HELP] key is pressed, the pressure is assumed to be recovered and the system enters the ready mode.
- (2) In the Ready mode, the alarm sounds and the error message appears in the LCD.  
If pressure returns to the normal range after [HELP] key is pressed, the pressure error is assumed to be recovered and the system enters the ready mode.

### 6.3.1.2 Pressure/Vac Error [250 mmHg Vacuum Error]

- Description : 250 mmHg vacuum is outside the operating range.
- Function : The system ensures the sample drainage from the transducer chamber and the manometer operation.
- Check method : A/D converter converts voltage of the 250 mmHg vacuum sensor. The system checks if the vacuum reading is within the allowable range.
- In the Ready mode : System monitors at a constant timing (every 200 ms)  
Allowable range : From 230 to 270 (mmHg)  
System assumes to be an error when vacuum deviates from the allowable range for more than 1.2 seconds continuously.
- During analysis : Whole Blood (WB) Mode  
At start of sequence 1 (0.5 seconds before draining from the mix chamber and W/R detection chamber)  
At 0.4 seconds after start of sequence 2 (HGB background convert sample aspirate)  
At start of sequence 4 (RBC charge)  
At 0.9 seconds after start of sequence 4 (Mix chamber drain, W/R detection chamber drain)  
At 1.6 seconds after start of sequence 7 (HGB sample convert sample aspirate)  
At start of sequence 9 (0.5 seconds before draining from W/R detection chamber)  
At 6.4 seconds after start of sequence 9 (HGB flow cell rinse solution aspirate)  
At 8.6 seconds after start of sequence 9 (W/R detection chamber drain)  
At 0.1 seconds after start of sequence 10 (HGB flow cell rinse solution aspirate)  
Pre-Diluted (PD) Mode  
At start of sequence 1 (0.5 seconds before draining from the mix chamber and W/R detection chamber)  
At 0.4 seconds after start of sequence 2 (HGB background convert sample aspirate)  
At 1.4 seconds after start of sequence 3 (Mix chamber drain, W/R detection chamber drain)  
At 1.6 seconds after start of sequence 7 (HGB sample convert sample aspirate)  
At start of sequence 9 (0.5 seconds before draining from W/R detection chamber)  
At 8.9 seconds after start of sequence 9 (HGB flow cell rinse solution aspirate)  
At 11.6 seconds after start of sequence 9 (W/R detection chamber drain)  
At 0.1 seconds after start of sequence 10 (HGB flow cell rinse solution aspirate)  
Allowable range: From 100 to 270 (mmHg)  
Assumed to be an error when vacuum deviates from the allowable range at the specified timing.
- KX-21's action : (1) During analysis, the error message appears in the LCD after the sequence for aspirated sample has completed and the data is output (all data becomes "").  
If vacuum returns to the normal range after [HELP] key is pressed, the vacuum error is assumed to be recovered and the system enters the ready mode.
- (2) In the Ready mode, the alarm sounds and the error message appears in the LCD.  
If vacuum returns to the normal range after [HELP] key is pressed, the vacuum error is assumed to have recovered and the system enters the ready mode.

A

Screen Display: Pressure/Vac Error

Error Code

0.5 kg/cm<sup>2</sup> Pressure  
11105.XXXXX.ZZZZZ

250 mmHg Vacuum  
11225.XXXXX.ZZZZZ

XXXXX: Value when error occurred  
ex) 0.25 kg/cm<sup>2</sup> → 250  
225 mmHg → 225

ZZZZZ: Sequence No. when error occurred  
ex) Sequence 3 → 3

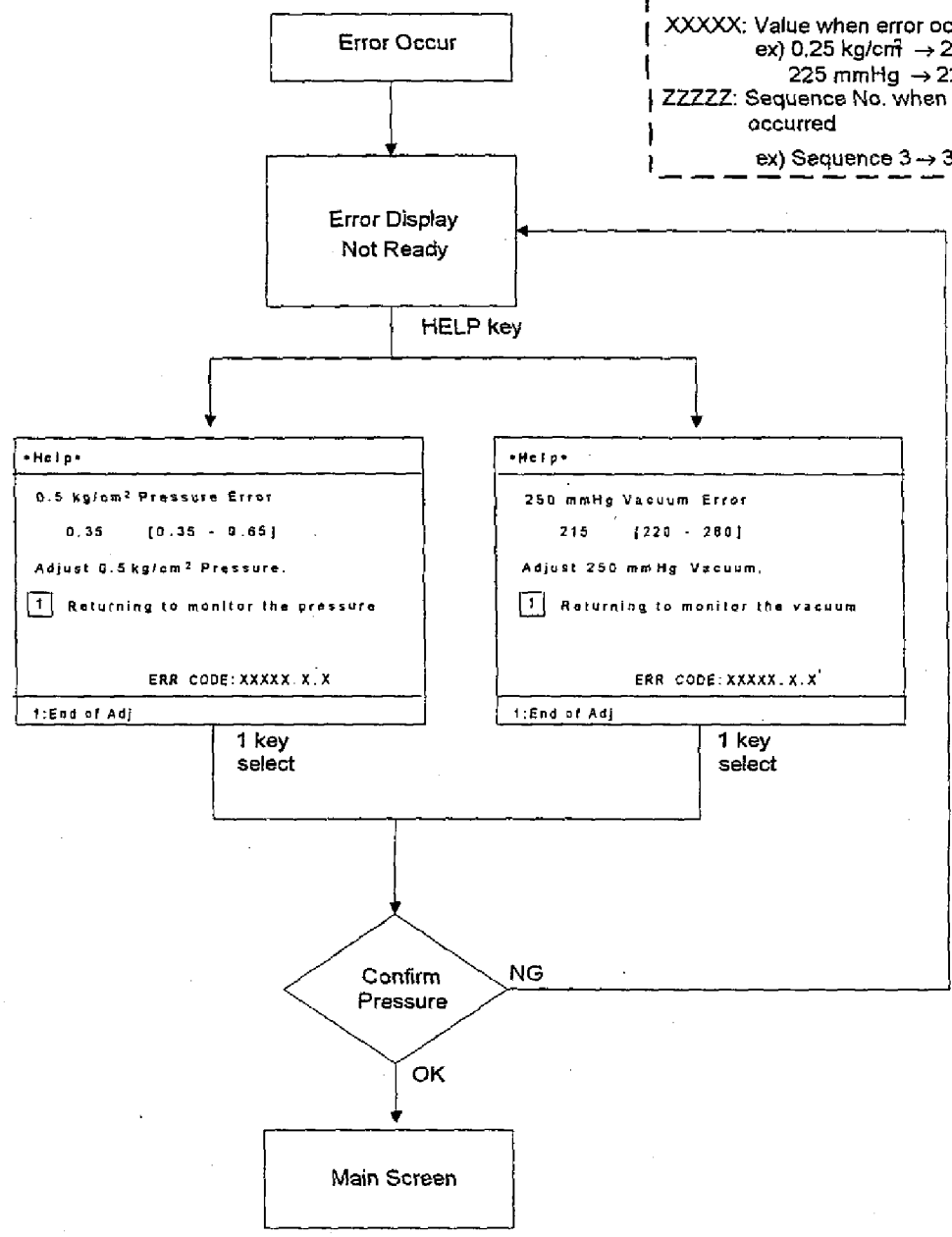

### 6.3.1.3 Pressure/Vac Error [Pressure Lower Error]

Description : 0.5 kg/cm<sup>2</sup> pressure is lowered for more than the specified time period, and the analysis process is not assured on the following samples.

Function : The system secures the operation of the solenoid valve, DP, etc.

Check method : A/D converter converts voltage of the 0.5 kg/cm<sup>2</sup> pressure sensor which is connected to the 0.5 kg regulator. The system checks if the pressure reading is within the following range.

During analysis : System monitors at a constant timing (every 200 ms).  
Allowable range: 0.2 kg/cm<sup>2</sup> or higher  
System assumes to be an error when pressure deviates from the allowable range for more than 1.2 seconds continuously.

KX-21's action : The system immediately stops the currently running sequence and turns OFF all the solenoid valves and pneumatic unit. Subsequent operation cannot be continued and waited in power OFF condition.

Screen Display: Pressure/Vac Error

Error Code

11901.XXXXX.ZZZZZ

XXXXX: Value when error occurred  
ex) 0.25 kg/cm<sup>2</sup> → 250

ZZZZZ: Sequence No. when error occurred  
ex) Sequence 3 → 3

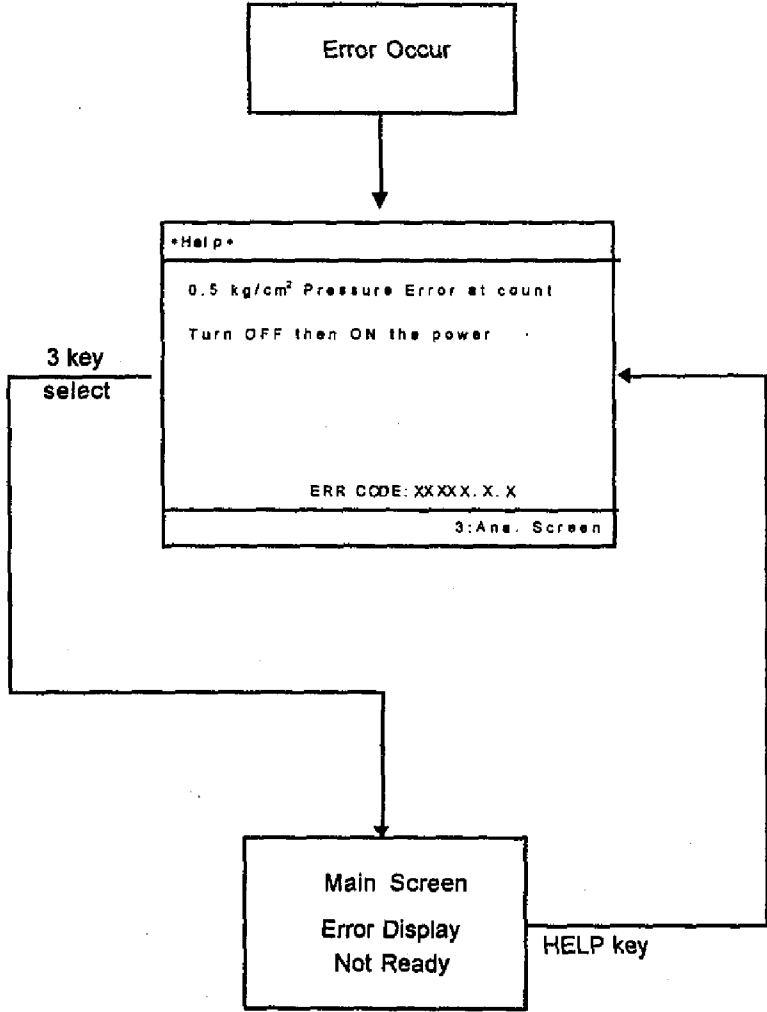



## 6.3.2 Chamber

### 6.3.2.1 Waste Not Draining

- Description : The waste chamber fails to drain.
- Function : The system secures drainage of waste fluid from the waste chamber and acceptance of new waste.
- Check method : System checks that the float switch in the waste chamber (sensor FSW1) is ON (the float is in the lower limit).  
In the Ready mode : System monitors every 100 nsec.  
When the Main Unit is ON : System monitors at SV1 OFF (completion of drain).
- KX-21's action : (1) During analysis, the analysis data and the error message appear in the LCD after the sample analysis has completed and the data is output (all data becomes "\*\*\*").  
System waits for the [HELP] key entry.  
If pressure returns to the normal range after [HELP] key is pressed, the pressure is assumed to be recovered and the system enters the ready mode.
- (2) In the Ready mode, the alarm sounds and the error message appears in the LCD.  
The system becomes ready when waste chamber draining sequence is performed without an error during starting up.

Screen Display:  
 Waste Not Draining  
 Error Code  
 12900.0.0

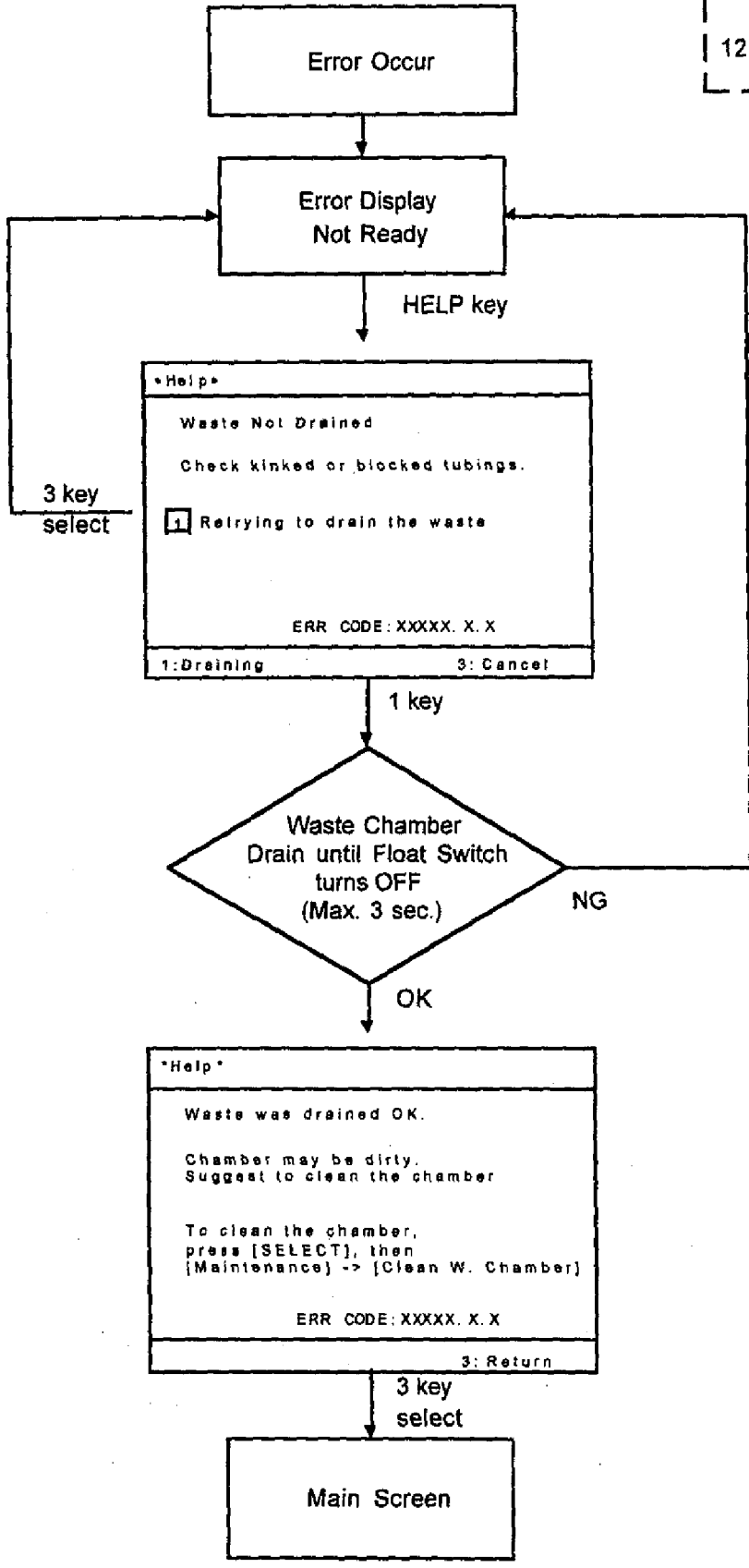

### 6.3.2.2 Replenish Diluent

Description : Diluent (CELLPACK) cannot be aspirated into the reagent chamber in specified time, or air bubbles enters, resulting the diluent chamber float switch (sensor FSW2) OFF and ON.  
moving up and down.

Function : The system secures reagent volume required for analysis. Or detects that the air bubbles enters the diluent chamber.

Check method : (1) Monitoring conditions:  
1) System assumes the entering of the air bubbles when the float switch (lower) turns ON between 0.2 seconds and 0.4 seconds after the float switch (upper) turns OFF.  
2) System assumes to be an error when longer than 7 seconds.  
3) System assumes to be an error when the replenishing time is longer than 15.0 seconds.  
(2) On the normal analysis, the above 1) and 2) monitoring are performed.  
(3) On the initialization, or on the reagent replenish sequence, the above 3) monitoring is performed.  
(4) On the other sequences, the above 2) monitoring is performed.  
(5) In the Ready mode, monitoring is not performed.

KX-21's action : Turns the solenoid valve for diluent aspiration ON until the float switch turns OFF. When the error is resolved, the system enters the ready mode.

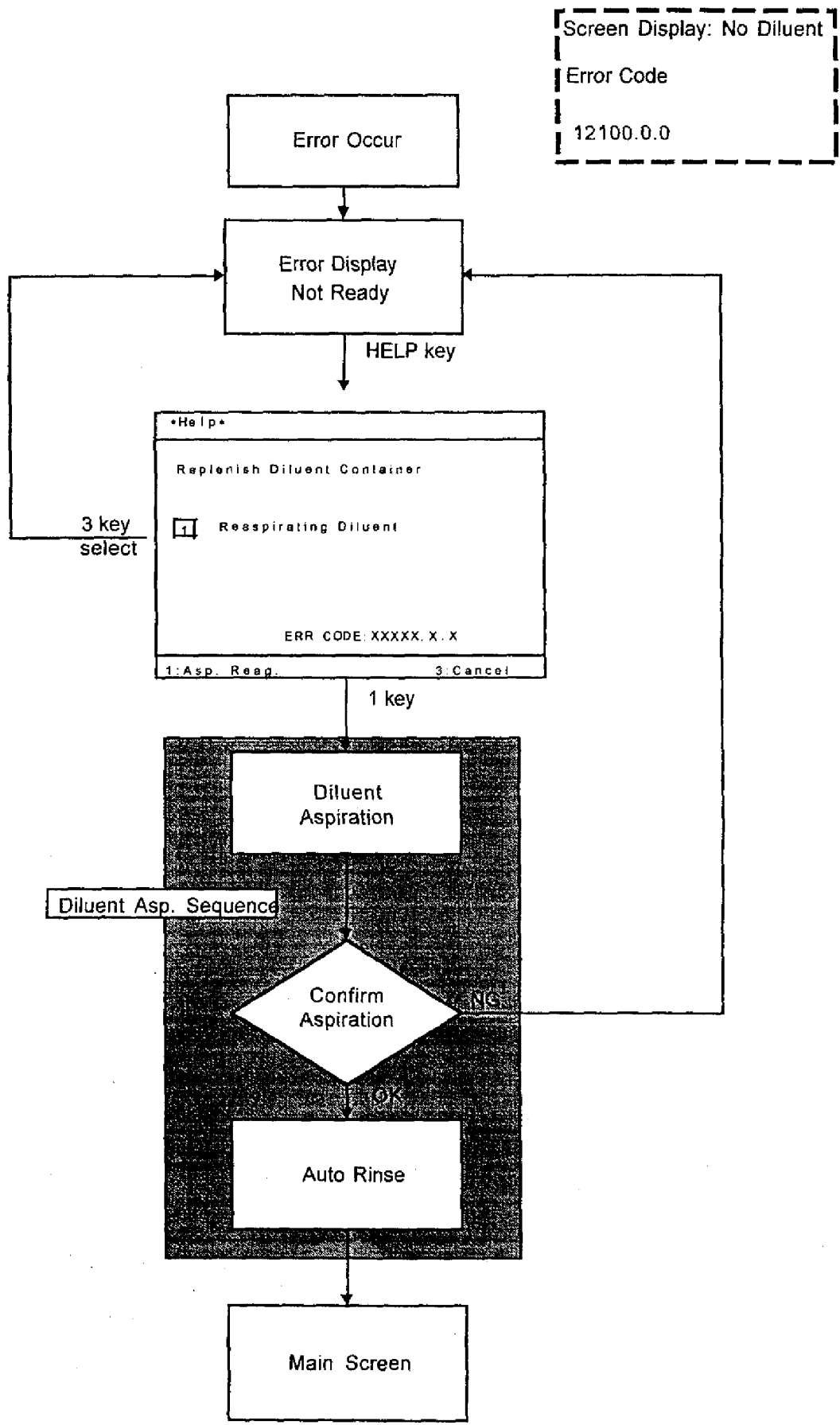

### **6.3.2.3 Replenish Lyse**

- Description** : The usable cycles reaches the specified count after the float switch for monitoring the lyse reagent turns ON.
- Function** : The system secures lyse reagent volume remained for analysis.
- Check method** : System checks that the cycle is less than 95 for the 500 mL bottle after the float switch for monitoring the lyse reagent (FSW7) turns ON (for one second consecutively).
- KX-21's action** : The alarm sounds and the error message appears in the LCD. The system enters the ready mode after [HELP] key is pressed.

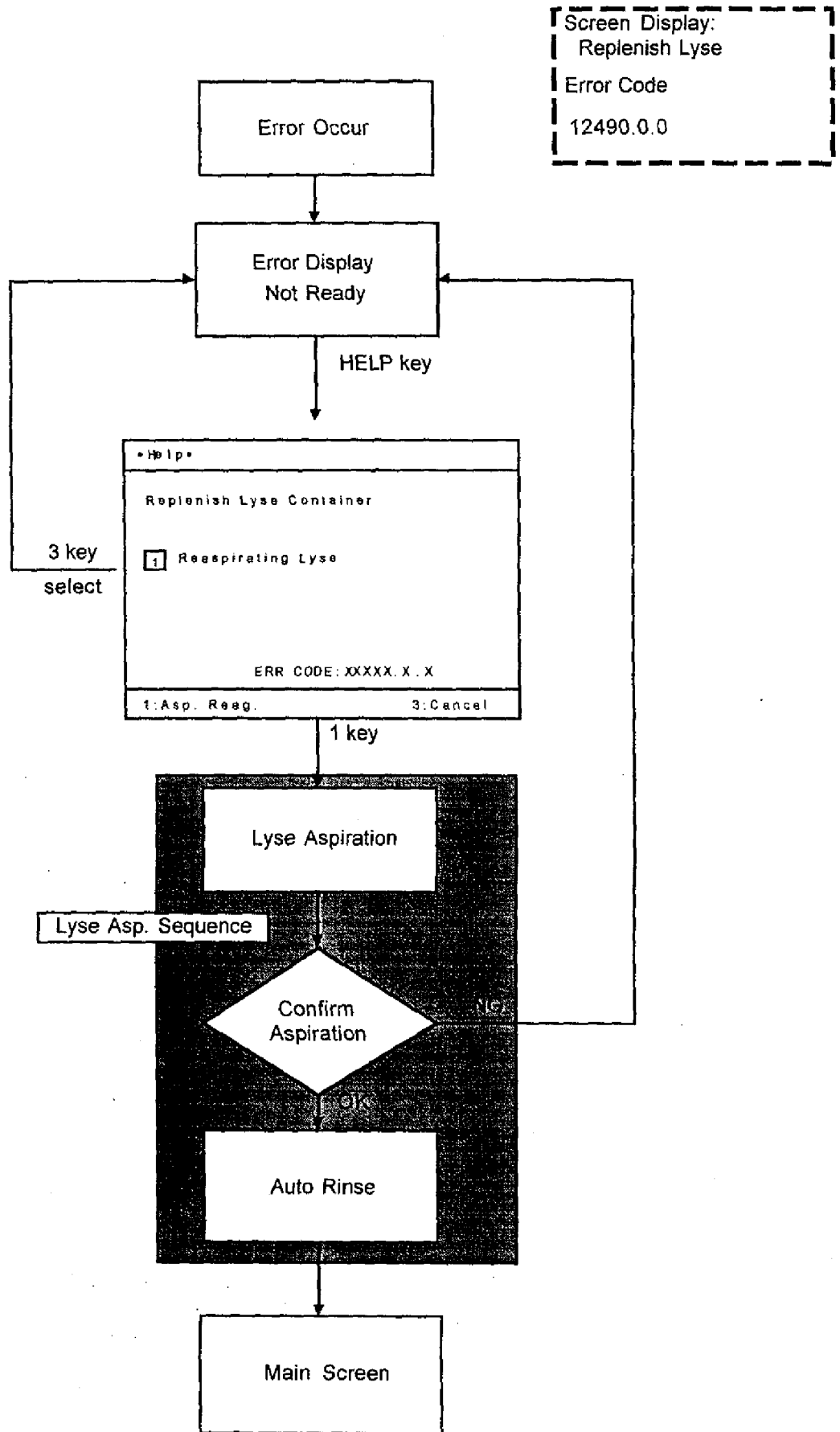

Screen Display:  
 Replenish Lyse  
 Error Code  
 12490.0.0

### 6.3.3 Built-in Printer

#### 6.3.3.1 No Printer Paper

Description : Paper has run out in the built-in printer.

Function : The system secures printing of measurement results.

Check method : System checks the bit of no-paper sensor in the built-in printer throughout the printing process.

KX-21's action : (1) System displays the error message on the LCD when no paper error is detected.  
(2) System waits for the [HELP] key entry after the sequence for the aspirated sample has completed. If the error recovers after the [HELP] key is pressed, built-in printer prints the data which has been paused. After the data is normally printed, system exits from the error.

Screen Display:  
 No Printer Paper  
 Error Code  
 34502.0.0

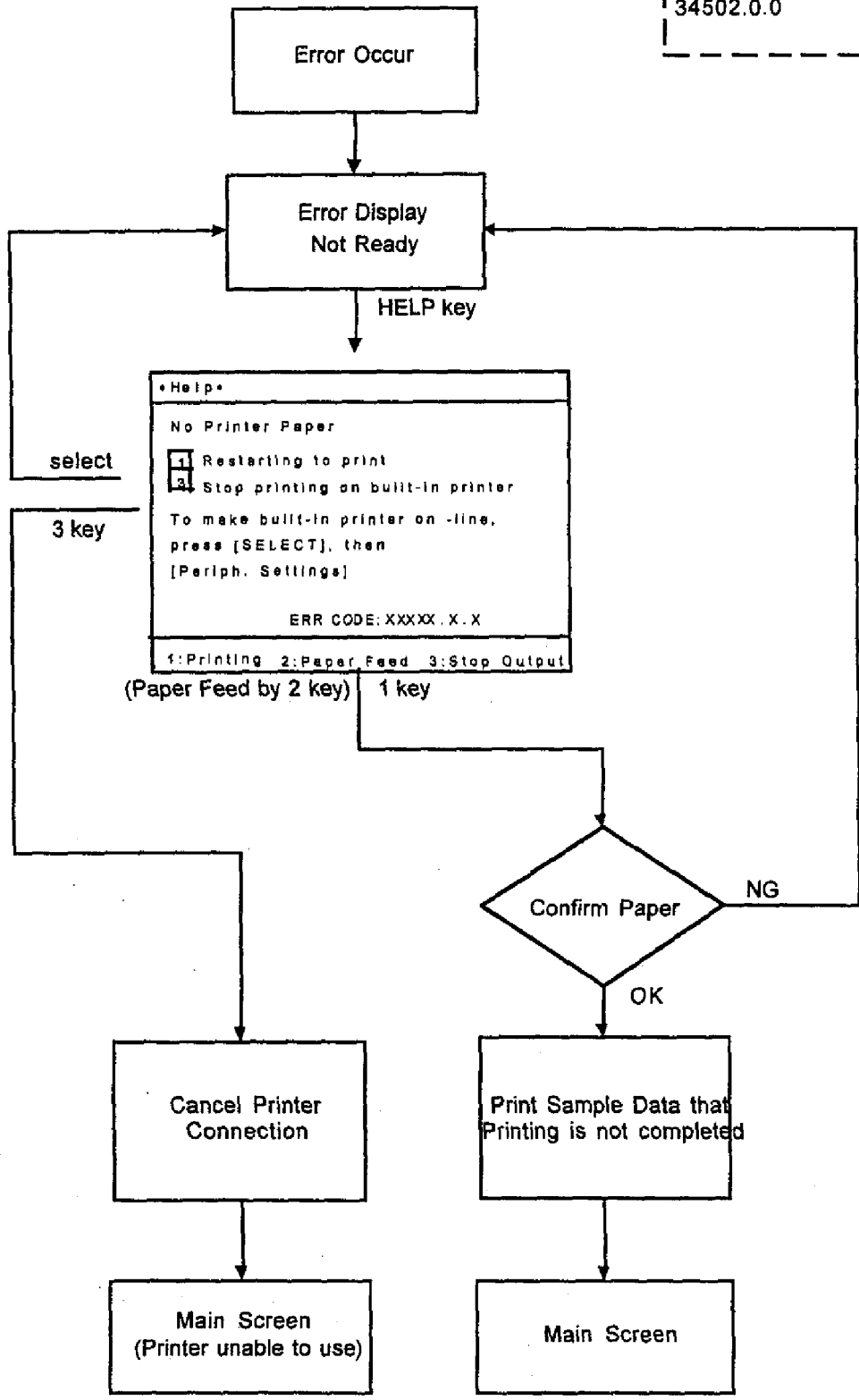



### 6.3.3.2 Printer Error

- Description : This message is issued when a hardware error occurs on the built-in printer, a cable connected to the built-in printer is disconnected, or the paper holder lever releases.
- Function : The system secures printing of measurement results and/or error messages.
- Check method : System checks the error-bit of the built-in printer throughout the printing process.
- KX-21's action : (1) System displays the error message on the LCD when a printer error is detected.
- (2) System waits for the [HELP] key entry after the sequence for the aspirated sample has completed. If the error recovers after the [HELP] key is pressed, built-in printer prints the data which has been paused. After the data is normally printed, system exits from the error.

Screen Display: Printer Error  
 Error Code  
 34501.0.0

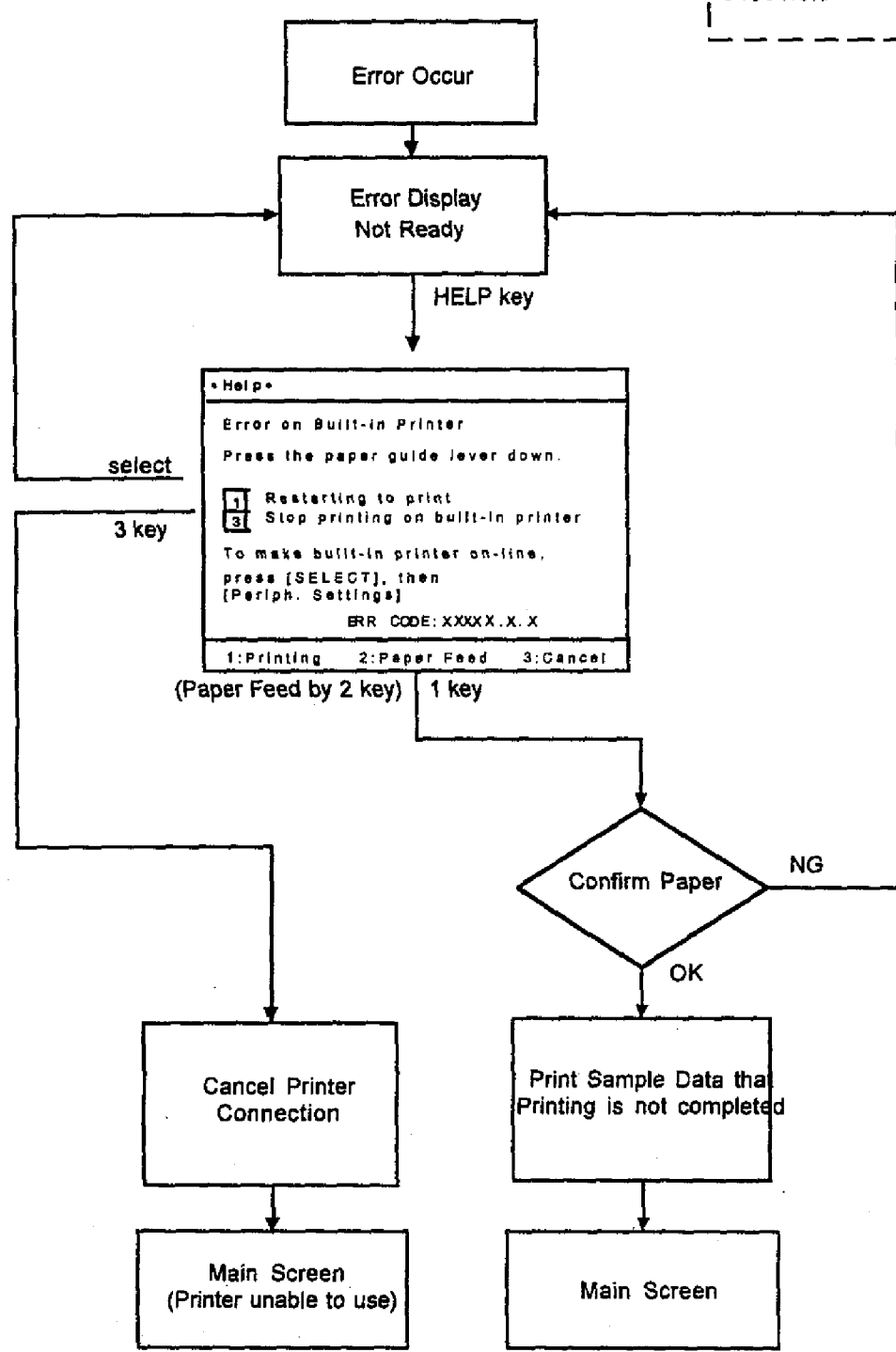

## 6.3.4 Motor

### 6.3.4.1 Rinse Motor Error [Rinse Motor Function Error]

- Description** : The rinse cup operation is abnormal. The rinse cup is at the lower position when the power turns ON.
- Function** : System prevents blood and rinsing solution from splashing when cleaning the whole blood aspiration pipette. System also eliminates carryover from the previous sample. In addition, system secures that the manual pipette does not get bent.
- Check method** : When the power is turned ON : System confirms that the rinse cup is not at the lower position when the power turns ON.  
When starting up : System monitors whether the rinse cup reaches the lower limit at the timing described in the timing chart is checked, by confirming that the photo-interrupter at the lower limit is ON.  
During analysis : System confirms that the rinse cup reaches the lower limit at 9 seconds after starting up.  
During the rinse cup operation test, an error is also issued if the motor is still active 1.6 seconds after the rinse cup starts ascending.
- KX-21's action** : System waits for the [HELP] key entry after the sequence for the aspirated sample has completed. System enters the ready mode when pipette rinsing operation is performed without an error during starting up. The system disables following operation and waits for powering OFF. Some part of store data can be performed by pressing the [HELP] key.

Screen Display: Rinse Motor Error  
Error Code  
13150.0.0

Error Occur



• Help •  
Error on Rinse Cup  
Turn OFF then ON the power.  
If Rinse Cup is out of position,  
Turn power OFF and correct manually.  
ERR CODE:XXXXX.X.X  
3:Ana. Screen

3 key  
select



Main Screen  
Error Display  
Analysis Disable

## 6.3.5 Temperature

### 6.3.5.1 Room Temp. High

### 6.3.5.2 Room Temp. Low

Description : Room temperature is out of the preset limit.

Function : System secures the HCT temperature compensation and PLT S/N (Signal to noise ratio), and avoids blood clotting on the cold agglutinin disease samples. System also secures hemolyzing in WBC samples.

Check method : System monitors A/D converted value of the thermistors installed in the WBC and RBC transducer chambers, and checks the temperature is within the following range.

During analysis : For 0.5 seconds before starting the counting. The mean value of the three counted values excluding the maximum and the minimum from the five counted values after turning the Start switch ON should be: From 10.0°C to 40.0°C

KX-21's action : After the sequence for aspirated sample has completed, built-in printer prints the data (the related data is printed normally). System displays the error message then enters the ready mode.

```

Screen Display: Room Temp. High
                Room Temp. Low

Error Code
Room Temp. High
21251.XXXXX.0
Room Temp. Low
21252.XXXXX.0

XXXXX : Temp. when error occurred
ex) 41.5 °C → 415

```

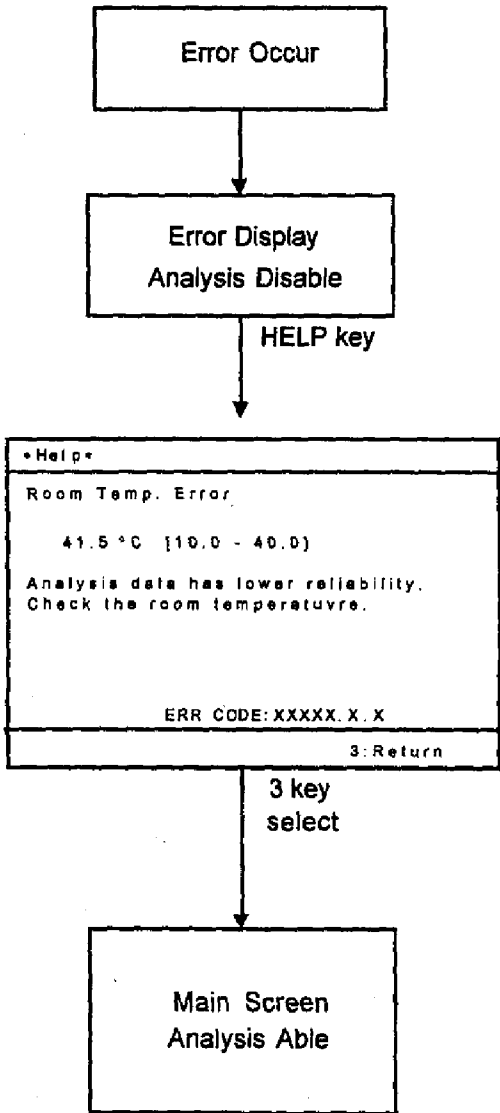

## 6.3.6 Analysis

### 6.3.6.1 Background Error

Description : Background value of any parameter exceeds the preset limit, and count results will be falsely increased.

Function : System ensures that the background value for all parameters is lower than the preset limit so as not to influence the analysis data.

Check method : System checks that the background value is lower than the following limits. A background error occurs if any parameter of the background value exceeds the preset limit either in the Auto Rinse procedure or in the background check at power ON.

WBC	: 0.3	[x10 <sup>3</sup> /μL]
RBC	: 0.02	[x10 <sup>6</sup> /μL]
HGB	: 0.1	[g/dL]
PLT	: 10	[x10 <sup>3</sup> /μL]

KX-21's action : System displays the error message on LCD then enters the ready mode.

Screen Display: Background Error
Error Code
22901.0.0

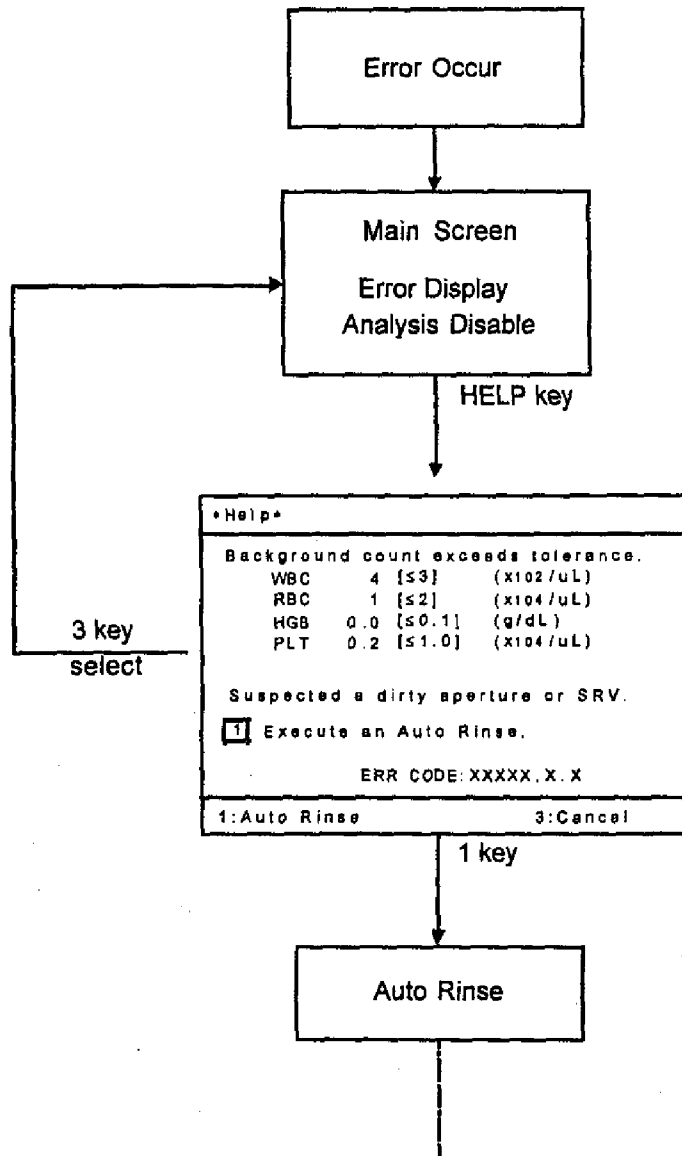



### 6.3.6.2 Sampling Error [RBC Sampling Error]

Description : During RBC counting, system detects the abnormal uniformity of the counted cell pulses that is beyond the preset limit.

Function : System monitors uniform cell pulses of RBC sample to monitor clog in the RBC transducer aperture.

Check method : System calculates sampling values every 0.5 seconds during RBC counting. When the maximum value, minimum value, and sum of sampling values satisfy the following equations, system judges that a noise is generated.

$$\frac{(\text{Maximum value} - \text{Minimum value} - 1250)}{\text{Sum of sampling values}} \times 100 > 2.0 [\%]$$

The sampling data range from 3 to 19 (1.0 s - 1.5 s) applies the above formula.

KX-21's action : (1) After the sequence for aspirated sample has completed, built-in printer prints the data (the related data is printed as ""). System displays the error message then enters the ready mode. The error is cleared.

(2) The count starting level for the sampling value is 25 fL.

### 6.3.6.3 Sampling Error [PLT Sampling Error]

Description : During PLT counting, system detects the abnormal uniformity of the counted cell pulses that is beyond the preset limit.

Function : System monitors uniform cell pulses of PLT sample to monitor clog in the RBC transducer aperture.

Check method : System calculates sampling values every 0.5 seconds during PLT counting. When the maximum value, minimum value, and sum of sampling values satisfy the following equations, system judges that a noise is generated.

$$\frac{(\text{Maximum value} - \text{Minimum value} - 100)}{\text{Sum of sampling values}} \times 100 > 2.0 [\%]$$

The sampling data range from 3 to 17 (1.0s - 8.5s) applies the above formula.

(Sampling data 17: number of the sampling data between 8.0 s and 8.5 s.)

KX-21's action : (1) After the sequence for aspirated sample has completed, built-in printer prints the data (the related data is printed as ""). System displays the error message then enters the ready mode. The error is cleared.

(2) The count starting level for the sampling value is 2 fL. (However, as for the upper limit, it has been already set by the analog board on the hardware. Therefore, the data contains much RBC data actually.)

### 6.3.6.4 Sampling Error [WBC Sampling Error]

Description : During WBC counting, system detects the abnormal uniformity of the counted cell pulses that is beyond the preset limit.

Function : System monitors uniform cell pulses of WBC sample to monitor clog in the WBC transducer aperture.

Check method : System calculates sampling values every 0.5 seconds during WBC counting. When the maximum value, minimum value, and sum of sampling values satisfy the following equations, system judges that a noise is generated.

$$\frac{(\text{Maximum value} - \text{Minimum value} - 200)}{\text{Sum of sampling values}} \times 100 > 2.0 [\%]$$

The sampling data range from 3 to 19 (1.0s - 9.5s) applies the above formula.

KX-21's action : (1) After the sequence for aspirated sample has completed, built-in printer prints the data (the related data is printed as ""). System displays the error message then enters the ready mode. The error is cleared.

(2) The count starting level for the sampling value is 30 fL.

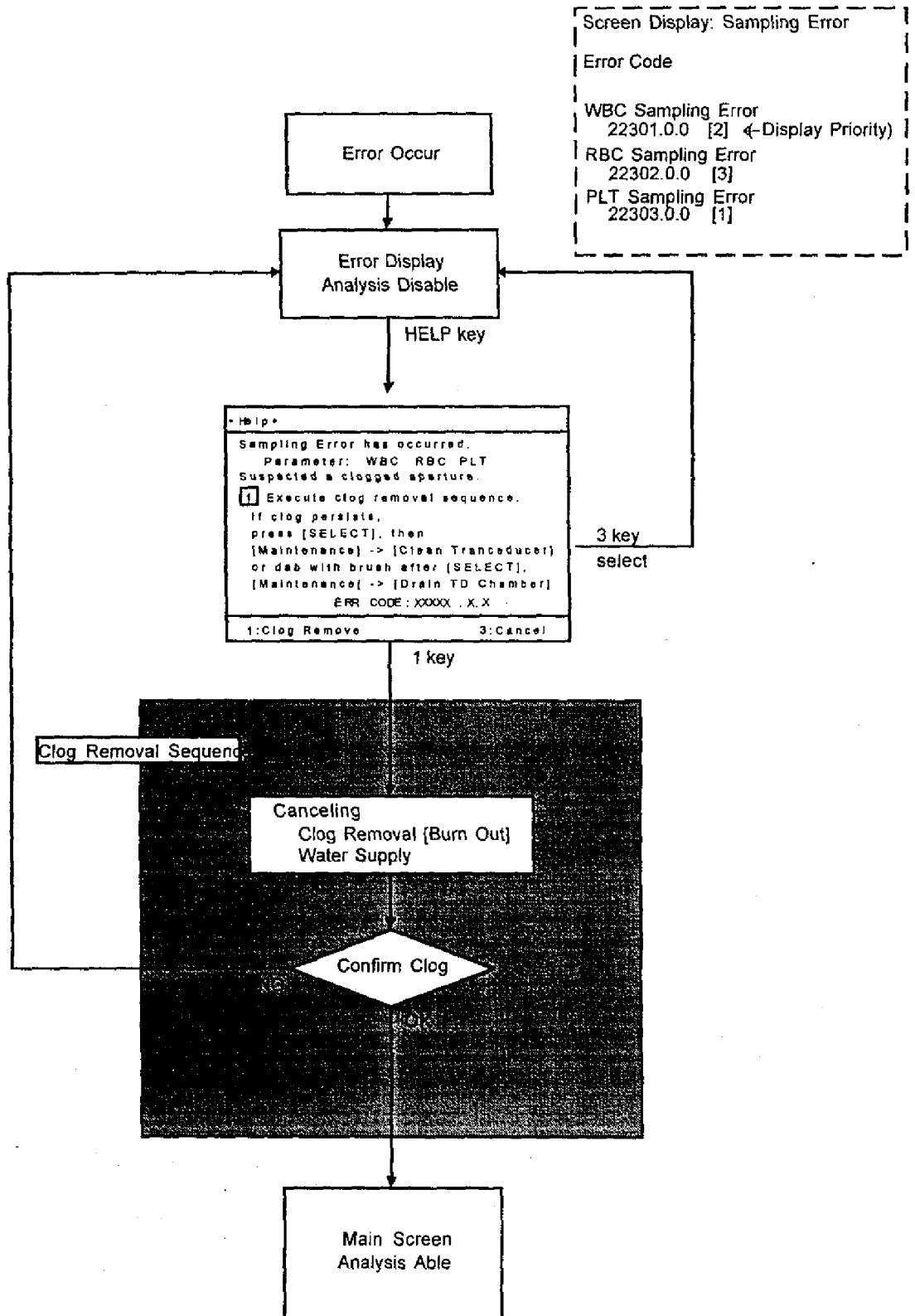

**6.3.6.5 Sampling Error [RBC CCSD Noise Error]**  
**6.3.6.6 Sampling Error [PLT CCSD Noise Error]**  
**6.3.6.7 Sampling Error [WBC CCSD Noise Error]**

Description : Overrun of A/D converter occurs. Overflow of counter occurs. No clearing the counter is performed.

Function : System secures the counting procedure.

Check method : Judged by status register's contents in gate alley after completing counting.

KX-21's action : After all the sequence for the aspirated samples are completed, built-in printer prints the data (the related data is printed as ""). System displays the error message then enters the ready mode.

```

Screen Display: Sampling Error
Error Code
WBC
  22201.0.0 [2] ←Display Priority)
RBC
  22202.0.0 [3]
PLT
  22203.0.0 [1]

```

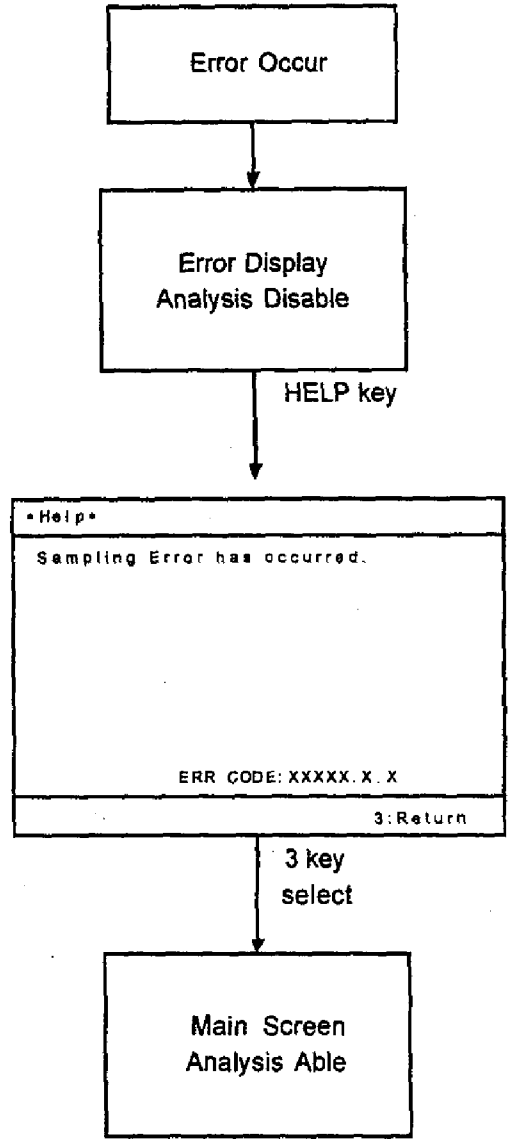

### 6.3.6.8 HGB Error

- Description : A/D converted HGB BLANK value or HGB sample value exceeds the preset limit.
- Function : System ensures that the HGB value is analyzed without any problem.
- Check method : HGB error occurs when the A/D converted HGB BLANK value or HGB sample value satisfies either of the following conditions.  
Blank < 50  
Blank > 10000  
(Sample - Blank) < -50  
(Sample - Blank) > 3600
- KX-21's action : After the sequence for aspirated sample has completed, built-in printer prints the data (the related data is printed as "\*\*\*"). System displays the error message then enters the ready mode.

Screen Display: HGB Error

Error Code

22501.XXXXX.ZZZZZ

XXXXX : HGB Converted value (background)  
ex) 50 → 50

ZZZZZ : HGB Converted value (sample)  
ex) 4500 → 4500

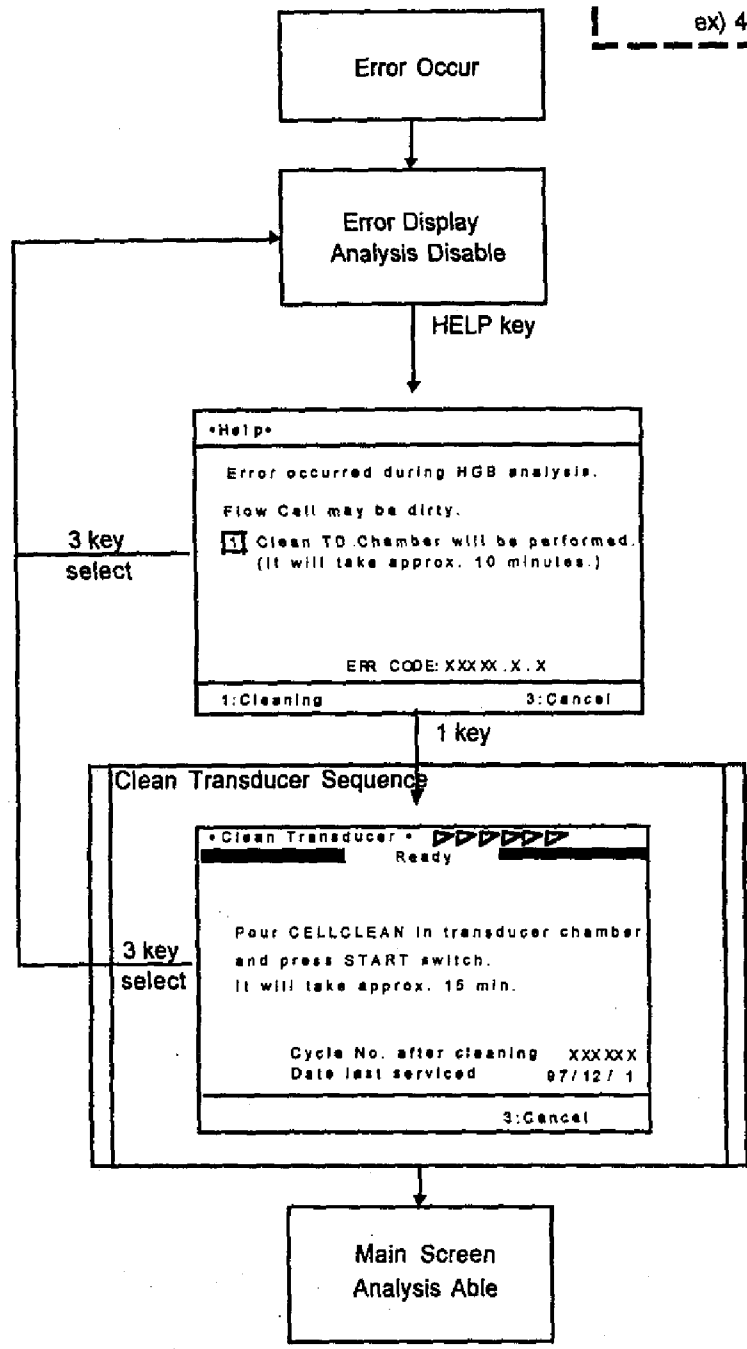

### 6.3.6.9 WBC Aperture Clog

Description : The WBC transducer aperture has clogging.

Function : System secures the WBC analysis.

Check method : System monitors the A/D converted value of the clogging signal from the both electrodes at the transducer, and checks the value is within the following range. Also, verify the sampling data at the completion of the counting is within the following range.

During Auto Rinsing: For 0.5 seconds before completion of the background check on the auto rinse, system monitors clogging rate.

Clogging rate:  $C \leq 120$

$$C = 3.333 \times 10 \times D \times 5.05/256 \\ - 2.961 \times T_{AD}^2 \times 10^{-2} \\ + 3.376 \times T_{TD} \\ - 6.590 \times 10$$

C: Clogging Rate (integral value, round to decimal point)

D: A/D converted value of the clogging voltage

$T_{TD}$ : Detector block temperature (\*\*.°C)

During analysis:

SE: Mean value of the three sampling data before the gate OFF

SH: Mean value of the sampling data 3 ~ 19 (1.0 s ~ 9.5 s)

$$SE/SH \geq 0.5$$

Sampling data n: number of the sampling data between (n-1)/2 and n/2

Sampling data 3: number of the sampling data between 1.0 s and 1.5 s.

Sampling data 19: number of the sampling data between 9.0 s and 9.5 s.

KX-21's action : After all the sequences for the aspirated samples are completed, the system enters the ready mode. All the related data are masked.

### 6.3.6.10 RBC Aperture Clog

Description : The RBC transducer aperture has clogging.

Function : System secures the RBC analysis.

Check method : System monitors the A/D converted value of the clogging signal from the both electrodes at the transducer, and checks the value is within the following range. Also, verify the sampling data at the completion of the counting is within the following range.

During Auto Rinsing: For 0.5 seconds before completion of the background check on the auto rinse, system monitors clogging rate.

Clogging rate:  $C \leq 120$

$$C = 3.333 \times 10 \times D \times 5.05/256 \\ - 2.961 \times T_{TD}^2 \times 10^{-2} \\ + 3.376 \times T_{TD} \\ - 6.590 \times 10$$

C: Clogging Rate (integral value, round to decimal point)

D: A/D converted value of the clogging voltage

$T_{TD}$ : Detector block temperature (\*\*.°C)

During analysis:

SE: Mean value of the three sampling data before the gate OFF

SH: Mean value of the sampling data 3 ~ 19 (1.0 s ~ 9.5 s)

$$SE/SH \geq 0.5$$

KX-21's action : After all the sequences for the aspirated samples are completed, the system enters the ready mode. All the related data are masked.

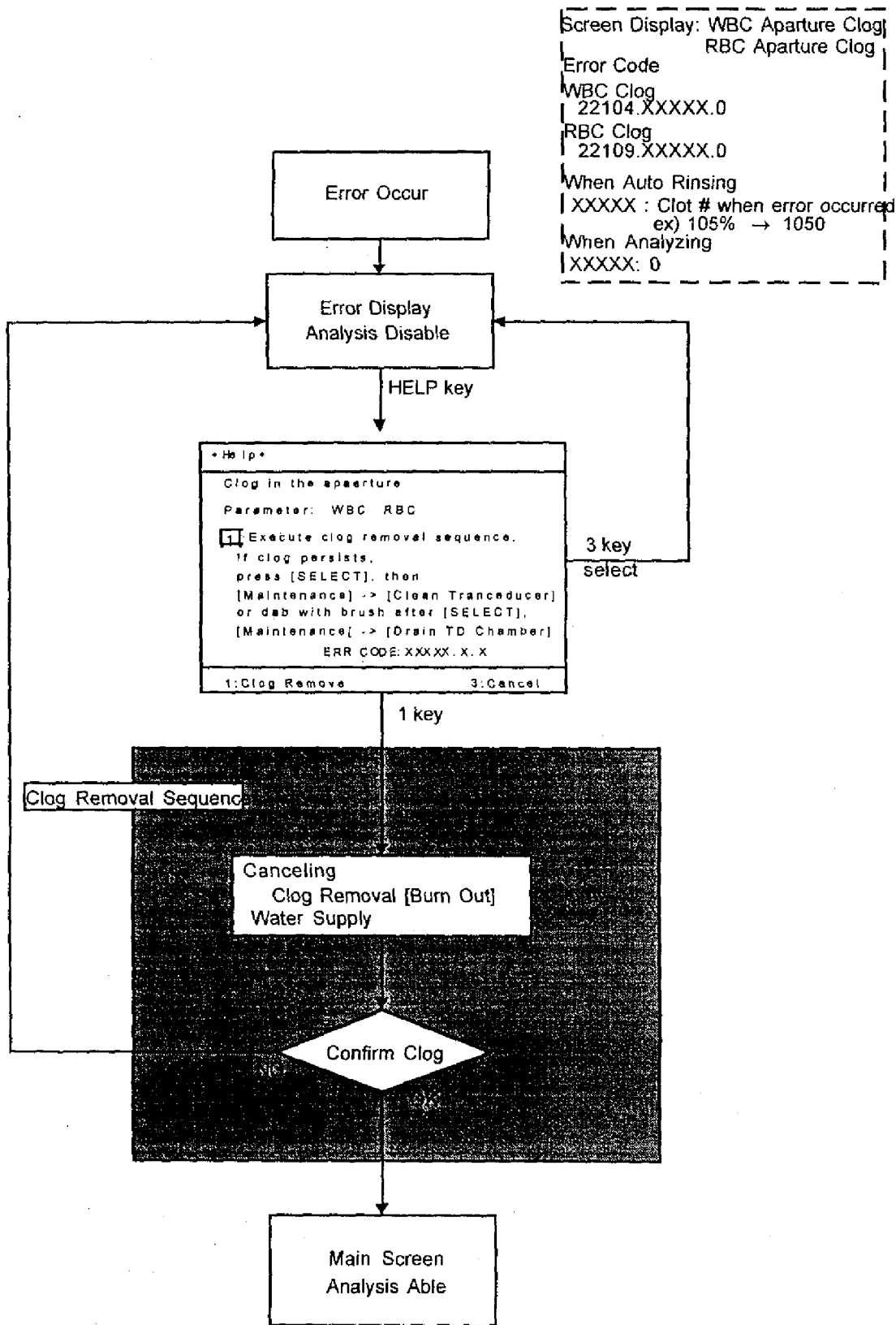

```

Screen Display: WBC Aparture Clog
                RBC Aparture Clog
Error Code
WBC Clog
22104.XXXXX.0
RBC Clog
22109.XXXXX.0
When Auto Rinsing
XXXXX : Clot # when error occurred
ex) 105% → 1050
When Analyzing
XXXXX: 0
  
```



### **6.3.6.11 Analysis Error [WBC/HGB Error (Tri-modal Particle)]**

- Description** : Tri-modal particle size distribution cannot be correctly divided.
- Function** : System monitors the faked lyse reagent.
- Check method** : System verifies that the number of cases when the tri-modal particle size cannot be correctly counted is less than 10 consecutively. (Error occurs when 11 or more abnormal tri-modal samples are counted consecutively.)
- KX-21's action** : The message [Analysis Error] is displayed and the alarm sounds. The message remains displayed until the error is recovered or the power is turned OFF. There are two types of the data display method.
- (1) Level 1: All the tri-modal data are displayed as "\_\_\_\_\_".
  - (2) Level 2: \* (low reliability mark) is attached to the obtained bi-modal data and the tri-modal data not analyzed automatically are displayed as "\_\_\_\_\_".

Screen Display: Analysis Error  
Error Code  
22605.0.0

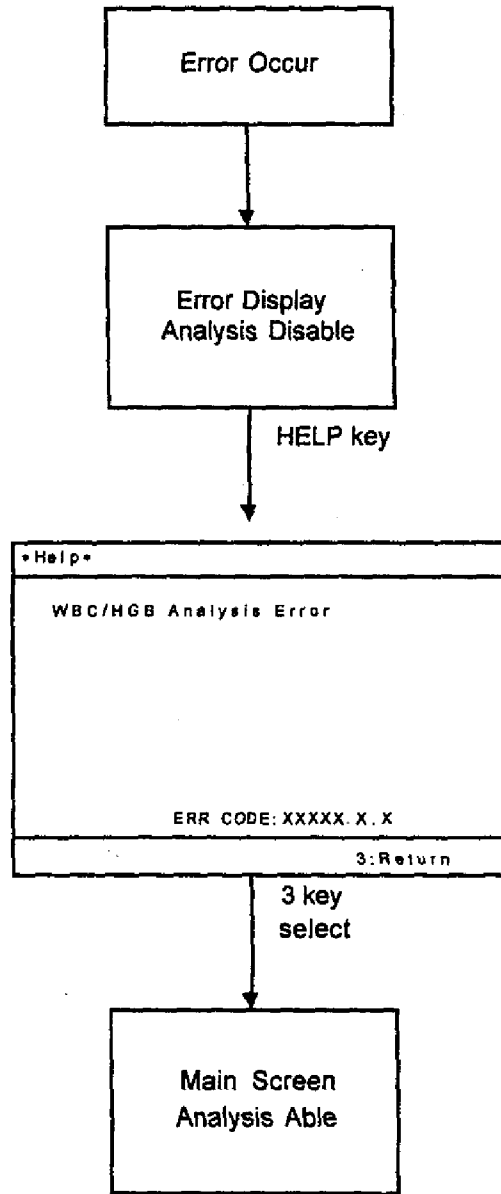

### 6.3.6.12 Analysis Error [Detect Sensitivity Error (Electrical Conductivity)]

Description : Electrical conductivity gets out of the control limit.

Function : System monitors the faked diluent.

**A** Check method : System verifies that the clogging rate (C) is within the range of  $(80 \leq C \leq 125)$ .

KX-21's action : The message [Analysis Error] is displayed and the alarm sounds. The message remains displayed until the error is recovered or the power is turned OFF. There are two types of the data display method.

(1) Level 1: HCT and MCV data are displayed as "\_\_\_\_\_".

(2) Level 2: \* (low reliability mark) is attached to the HCT and MCV data.

**A** NOTE: During Shutdown sequence, [RBC Aperture Clog] occurs at the same time.

Screen Display: Analysis Error  
Error Code  
22606.XXXXX.0  
XXXXX : Conductivity  
ex) 13.1 → 131

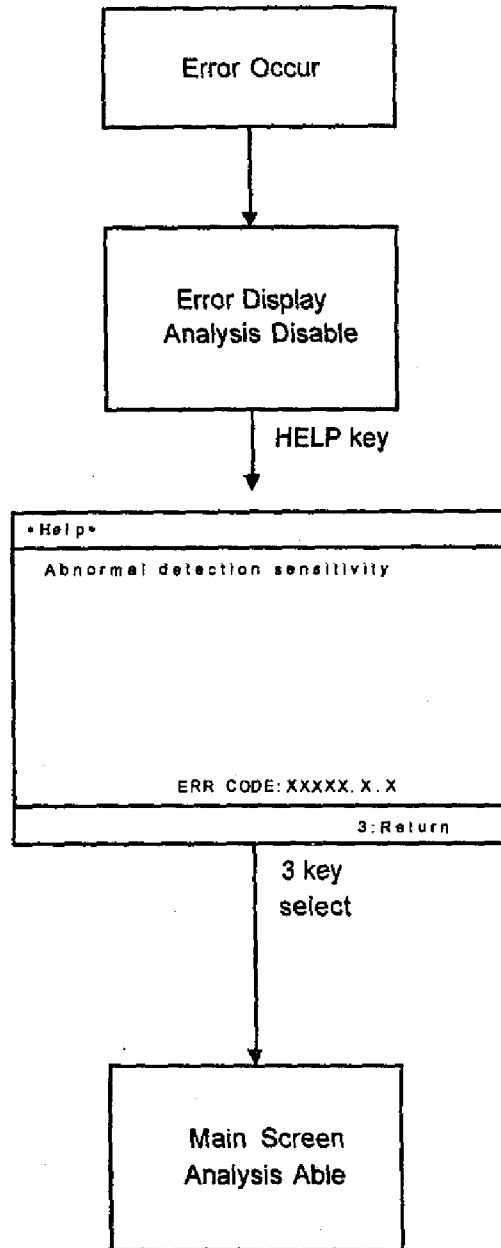

## **6.3.7 Memory**

### **6.3.7.1 Memory Error [RAM Error]**

**Description** : The main CPU detects an error to access the RAM (Random Access Memory).

**Function** : System ensures that the main CPU accesses the RAM without any problem.

**Check method** : System writes test data to a certain address at power-on, and checks whether the same data is read later. System repeats the same check procedure sequentially for every RAM address.

**KX-21's action** : System stops the operation immediately. The error is reset by turning OFF the power switch.

### **6.3.7.2 Memory Error [ROM Error]**

**Description** : The main CPU detects an error to read data from ROM (Read Only Memory).

**Function** : System ensures that the main CPU reads the program from the ROM correctly.

**Check method** : System performs a ROM checksum (reads data from the entire area, calculates the total, and finds the 8 low order bits). Then, system checks that the value matches the checksum value stored in the ROM.

**KX-21's action** : System stops the operation immediately. The error is reset by turning OFF the power switch.

Screen Display: Memory Error  
Error Code  
RAM Error  
32105.0.0  
ROM Error  
32101.0.0

Error Occur  
(when the power turned ON)

• Help •  
RAM error occurred.  
Turn OFF then ON the power.  
ERR CODE: XXXXX.X.X

\* Alarm doesn't stop

### 6.3.7.3 Setup Data Error

**Description** : The main CPU detects an error to read data from EEPROM (Electric Erasable Programmable Read Only Memory).

**Function** : System ensures that setting values are written and read correctly.

**Check method** : System performs a checksum in a data area and compares the calculated value with the checksum value stored in the EEPROM.

**KX-21's action** : System initializes the mismatched value of the data area to the factory default values. The data areas are separated as shown below.

- Block 1: User setting value
- Block 10: Production service setting value

```

Screen Display: Set Value Error
Error Code
32106.XXXXX.0
XXXXX : Error Block
ex) Block 1 → 1
    
```

```

Block 1 : Stored Data
          QC data, and
          User setting values
    
```

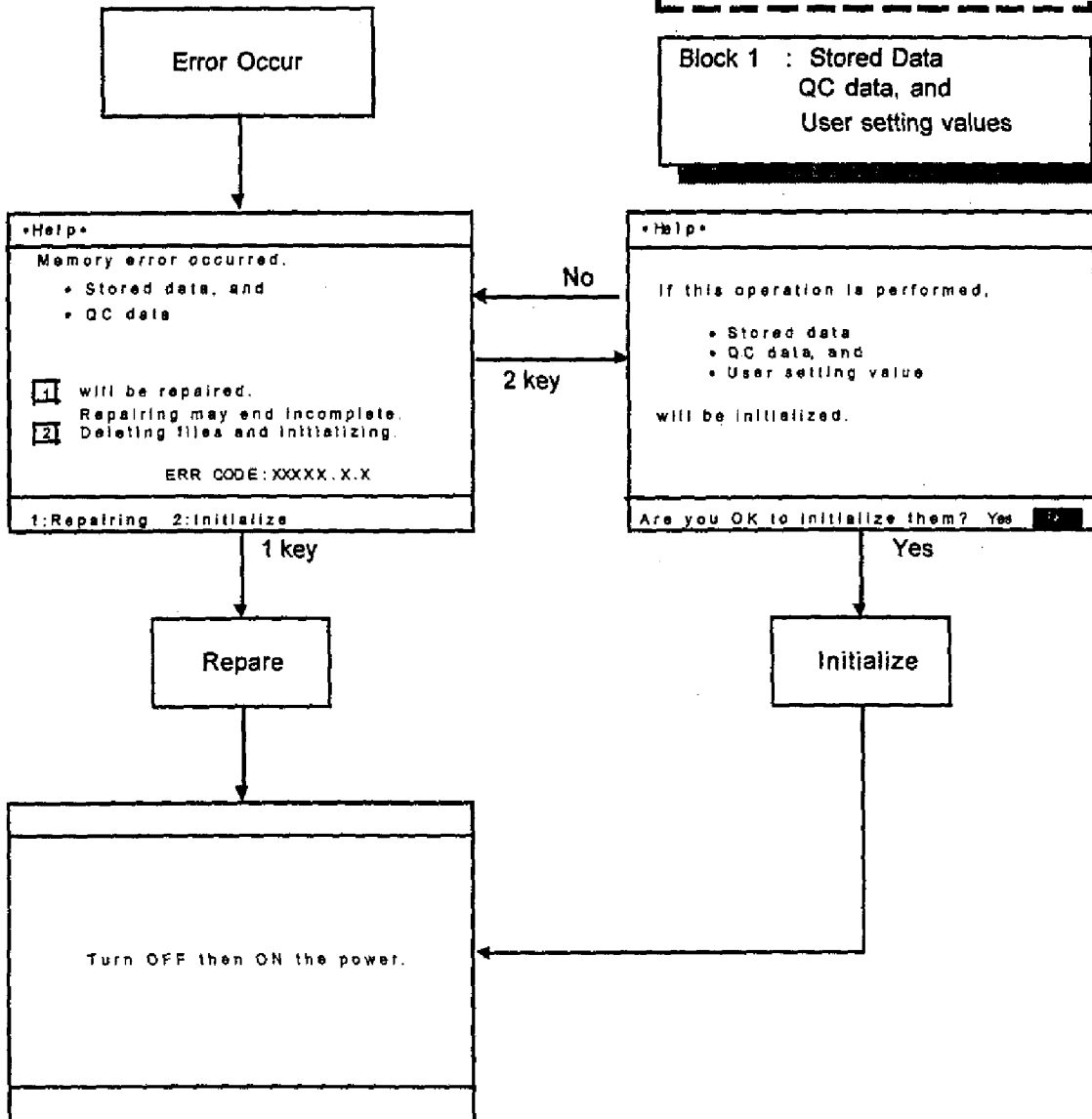

Screen Display: Set Value Error  
Error Code  
32106.XXXXX.0  
XXXXX : Error Block  
ex) Block 10 → 10  
Block 1 and 10 → 11

Block 1 : Stored Data  
QC data, and  
User setting values  
Block 10 : Factory, Service  
Setting values

Error Occur



•Help•  
RAM error occurred.  
Turn OFF then ON the power.  
ERR CODE:XXXXX.X.X

\* Alarm doesn't stop



#### **6.3.7.4 Print Error**

- Description** : The main CPU detects an error in the data output program and data cannot be printed on the Data Printer.
- Function** : System ensures that data is printed correctly on the Data Printer.
- Check method** : System checks whether the work memory can be reserved for printing the data.
- KX-21's action** : Subsequent operations are disabled. The error is reset by turning OFF the power switch.

Screen Display: Print Error  
 Error Code  
 32301.0.0

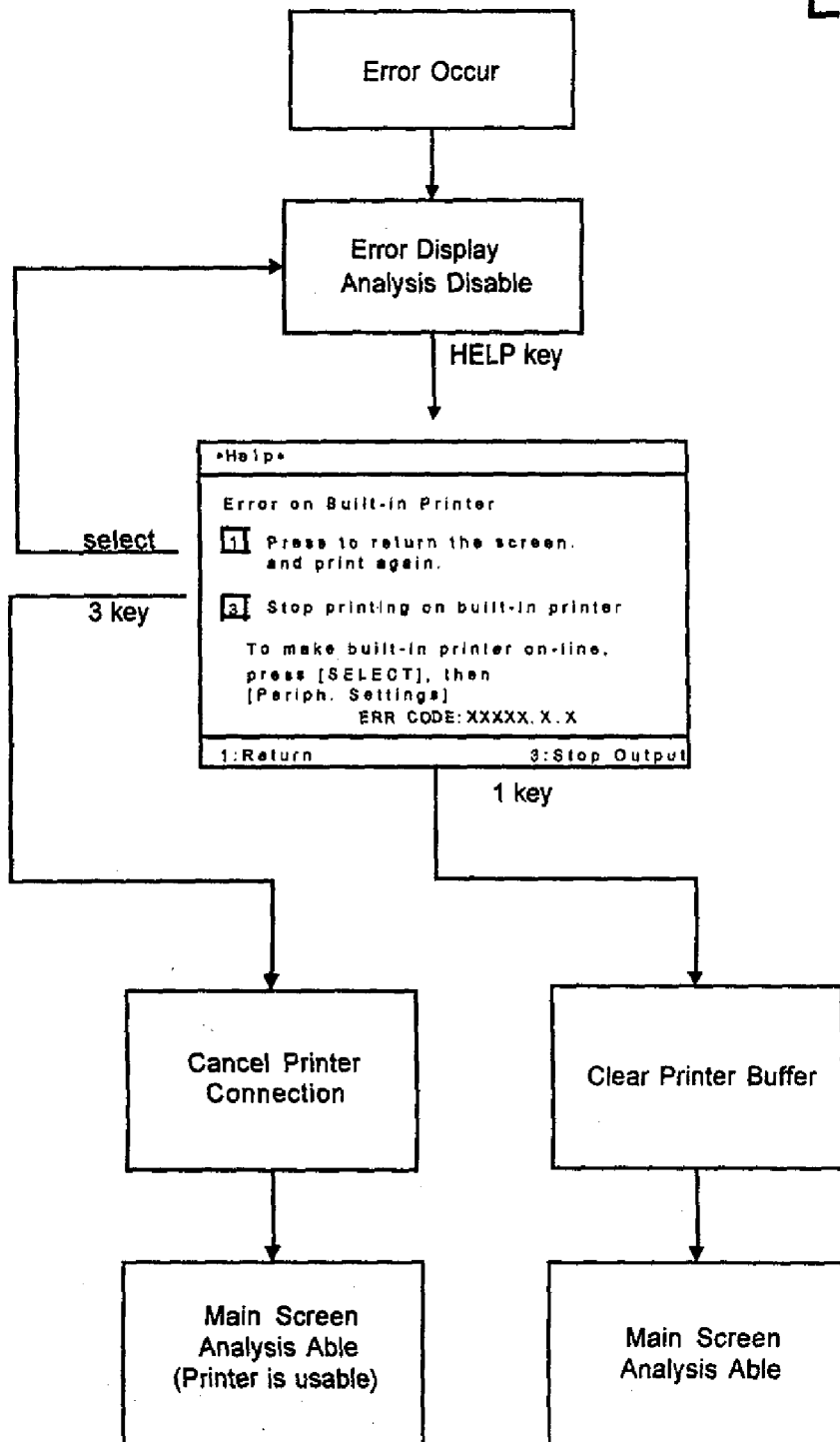

## 6.3.8 External Output

### 6.3.8.1 HOST Comm. Error

**Description** : The communication with Host Computer is failed. The analysis result cannot be transmitted to HOST. There are three type of HOST communication errors (Offline, Time Out, NAK Retry).

**Function** : System ensures that data is transferred to the host computer without any error.

**Check method** : System checks that the communication with Host Computer is succeeded.

**KX-21's action** : System waits for an instruction from the operator.

**Retry:** Data is transferred again. If system received an ACK, system returns to the ready mode. If system received a NAK again, the same error is issued.

**Cancel:** System stops transferring data. System disables the host connection setting and returns to the ready mode. (Data will not be transferred to the host computer until the setting is changed.)

Screen Display: Host Comm. Error

Error Code

Off-line  
33102.0.0

ACK Time Out Error  
33103.0.0

NAK Retry Error  
33106.0.0

Either of "Off-line", "ACK Time Out Error" or "NAK Retry Error" is displayed between \* and\*.

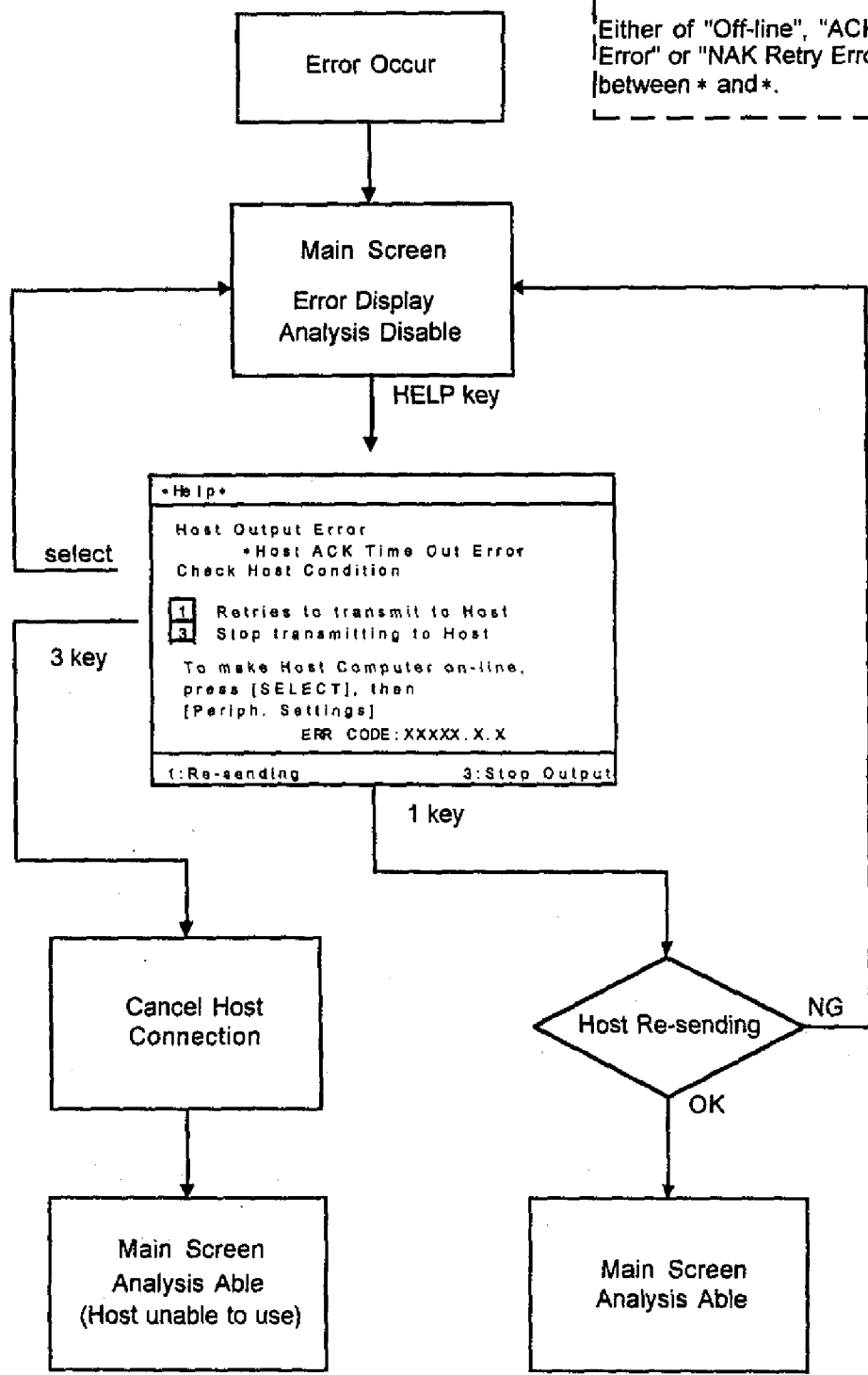

## 6.3.9 QC

### 6.3.9.1 QC Error [L-J Control Error]

- Description : The main CPU detects a situation that an L-J control error occurred.
- Function : System ensures that the main unit is under the quality control and the data has been out of the control limits.
- Check method : Statistically performs quality control using the weighted data of normal samples as the control data. If the data is not within the control limit, it is assumed to be the L-J control error.
- KX-21's action : After all the sequences for the aspirated samples are completed, the system enters the ready mode. The analysis data is effective.

### 6.3.9.2 QC Error [ $\bar{X}$ Control Error]

- Description : The main CPU detects a situation that an  $\bar{X}$  control error occurred.
- Function : System ensures that the main unit is under the quality control and the data has been out of the control limits.
- Check method : Statistically performs quality control using the average of control blood data of analyzed twice in a row as the control data. If the data is not within the control limit, it is assumed to be the  $\bar{X}$  control error.
- KX-21's action : After all the sequences for the aspirated samples are completed, the system enters the ready mode. The analysis data is effective.

Screen Display: QC Error  
L-J Control Error Code  
41101.0.0  
X Control Error Code  
41201.0.0

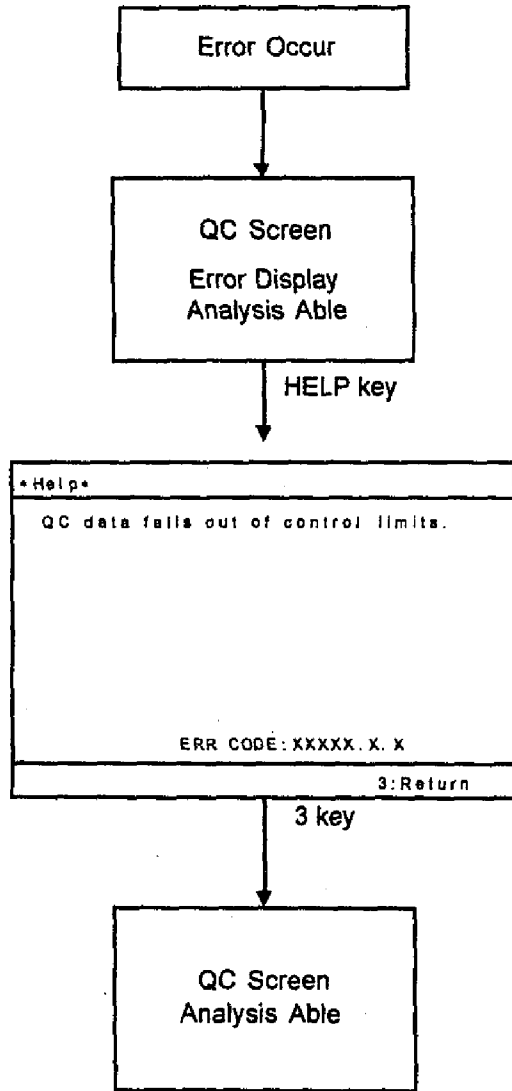

### **6.3.9.3 Calibration Error**

- Description : The calibration is performed with much change in values by once.
- Function : System ensures that the calibration cannot be performed more than specified.
- Check method : System checks the error when the calibration change between new and old exceeds 5% or the calibration change exceeds from 80% to 120%.
- KX-21's action : When the error occurs, the alarm sounds and the input setting value becomes ineffective.

Screen Display:  
Calibration Error

Error Code  
41801.0.0

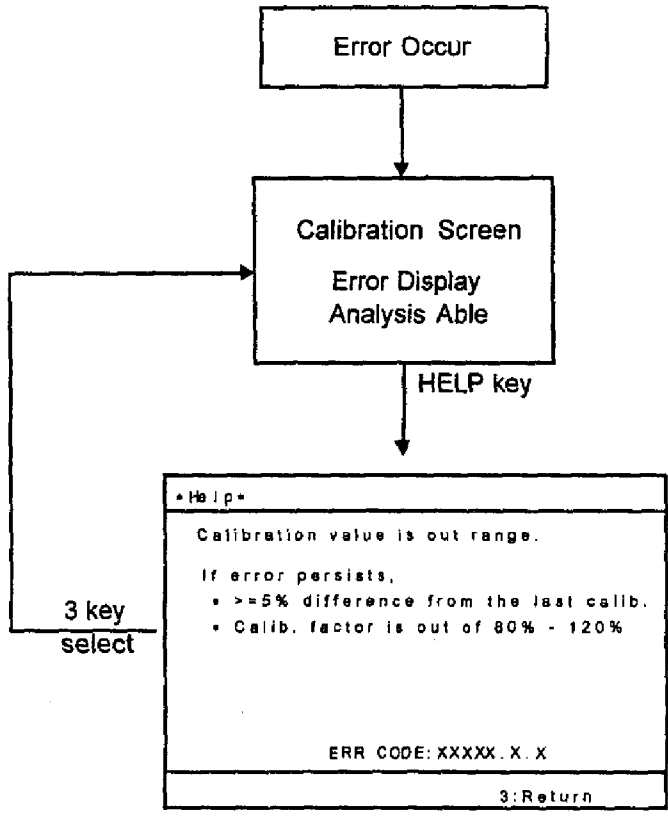



## **6.3.10 Maintenance**

### **6.3.10.1 Clean SRV**

- Description** : The main CPU detects a situation that the cycle counter reaches the preset value. It is the time to clean the SRV.
- Function** : System alerts the operator to clean the SRV.
- Check method** : System checks cycle count at power ON. When the SRV cycle count reaches 7500 or passes 3 months, this message is printed on the built-in printer. The cycle count increments by 1 for every execution of analysis sequence.
- KX-21's action** : System only print the message and could be operate the system as usual. The cycle count can be reset on the select menu in the maintenance mode.

Screen Display: Clean SRV  
Error Code  
55101.0.0

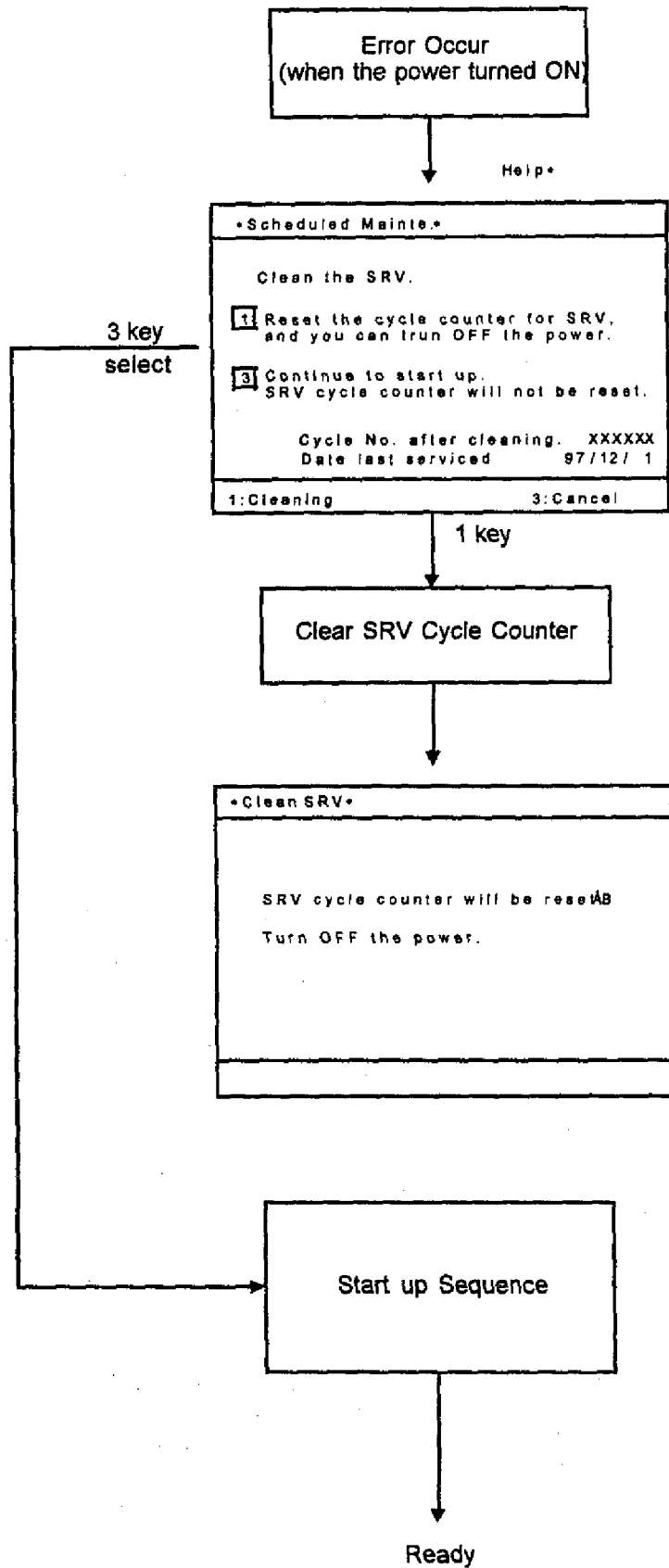

### **6.3.10.2 Clean W. Chamber (Clean Waste Chamber.)**

- Description** : The main CPU detects a situation that the cycle counter reaches the preset value. It is the time to clean the waste chamber.
- Function** : System alerts the operator to clean the waste chamber.
- Check method** : System checks cycle count at power ON. When the waste chamber cycle count reaches 2500 or passes a month, this message is printed on the built-in printer. The cycle count increments by 1 for every execution of analysis sequence.
- KX-21's action** : System only print the message and could be operate the system as usual. The cycle count can be reset on the select menu in the maintenance mode.

Screen Display:  
 Clean W. Chamber  
 Error Code  
 51103.0.0

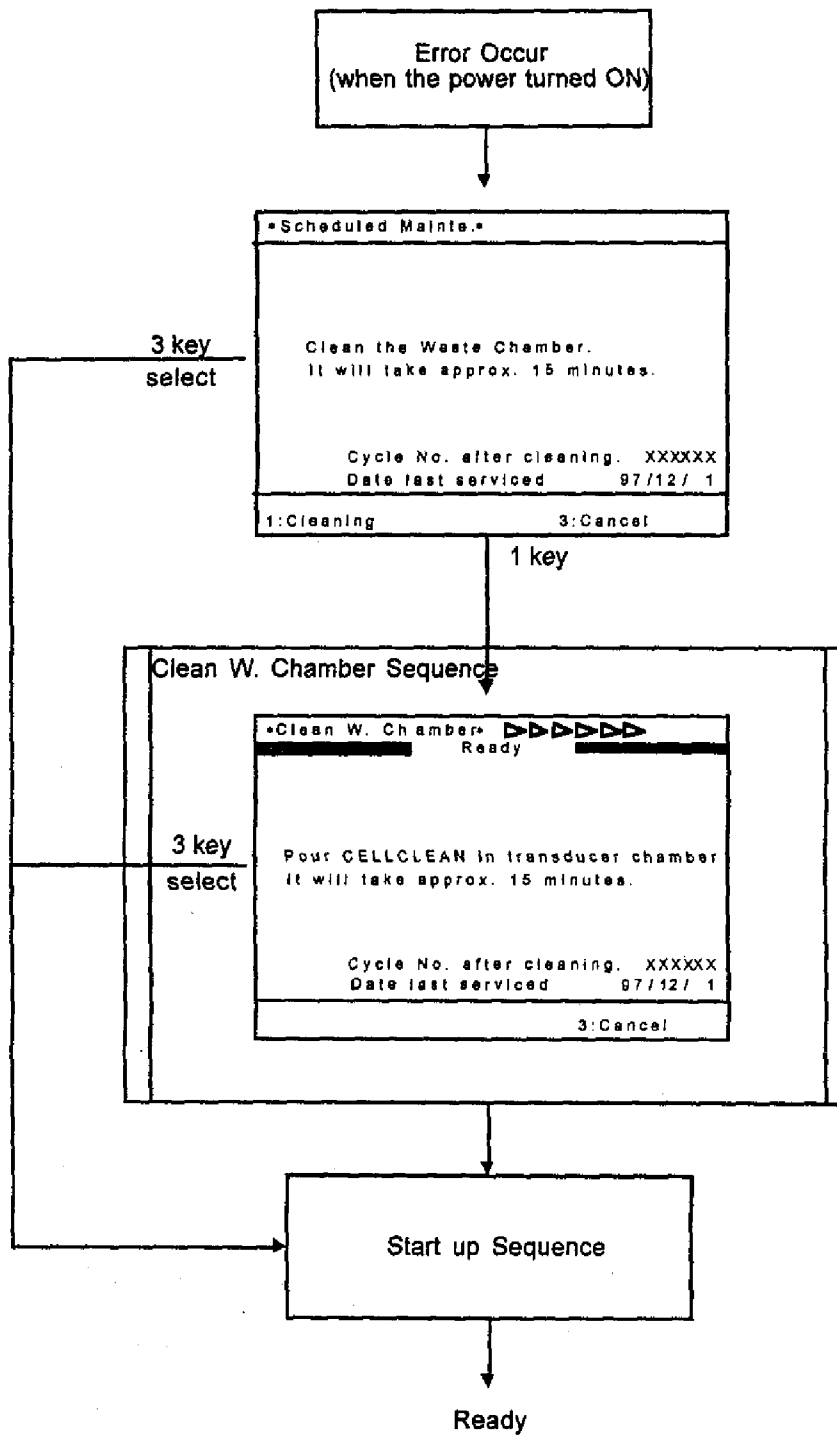

### **6.3.10.3 Clean Transducer**

**Description** : The main CPU detects a situation that the cycle counter reaches the preset value. It is the time to clean the transducer.

**Function** : System alerts the operator to clean the transducer.

**Check method** : System checks cycle count at power ON. When the transducer cycle count reaches 2500 or passes a month, this message is printed on the built-in printer. The cycle count increments by 1 for every execution of analysis sequence.

**KX-21's action** : System only print the message and could be operate the system as usual. The cycle count can be reset on the select menu in the maintenance mode.

Screen Display: Clean Transduce

Error Code

51105.0.0

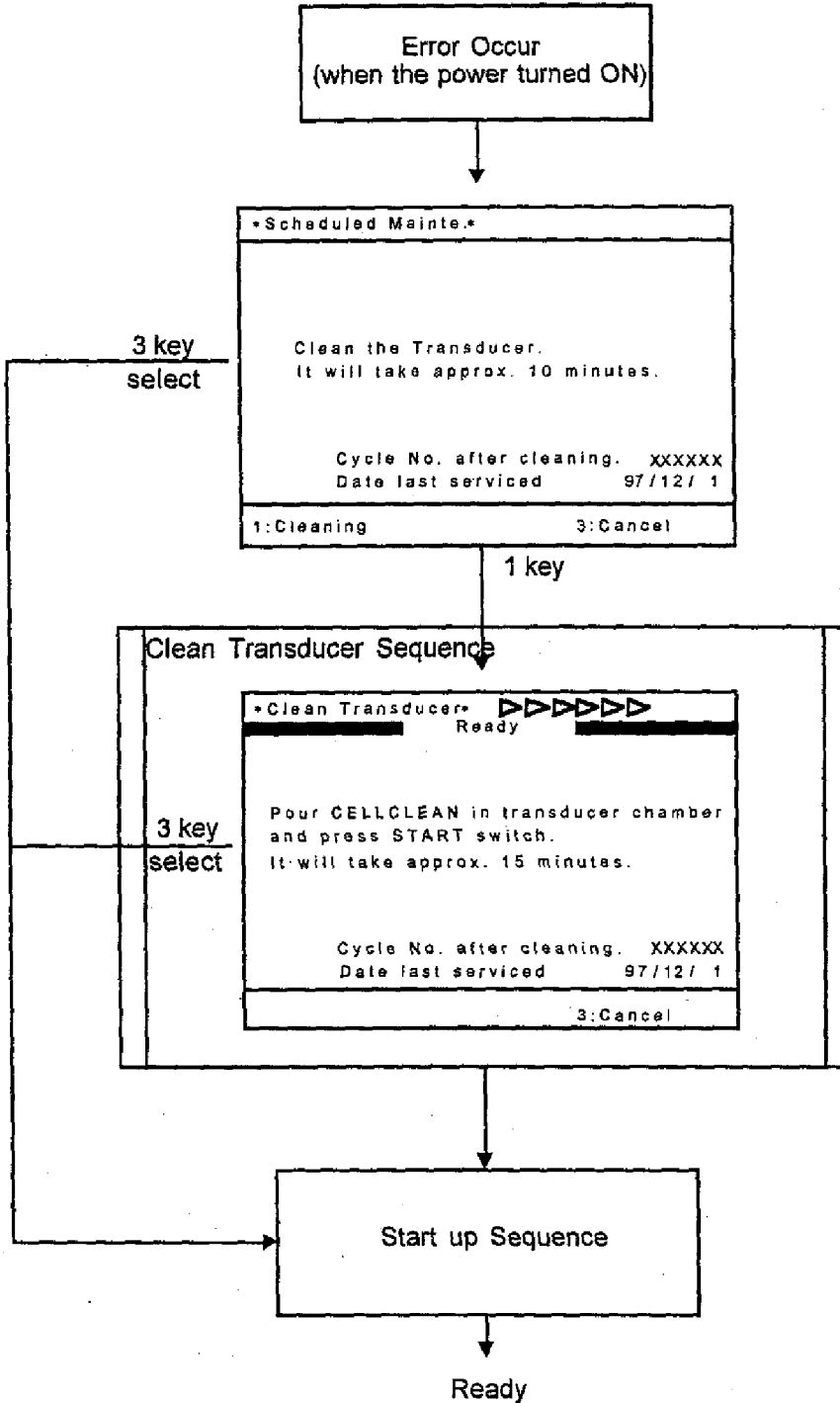

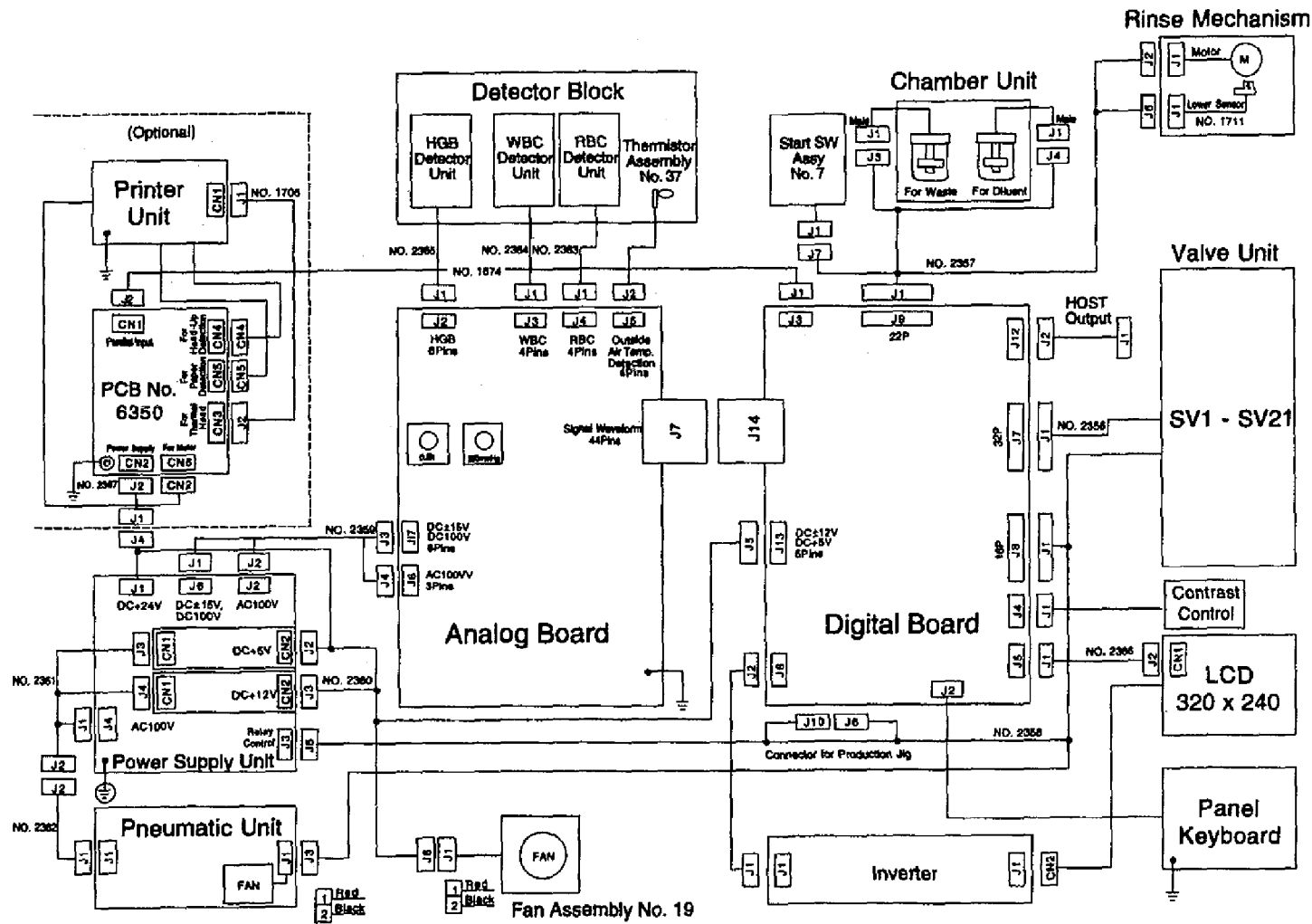

1	398G072
2	398J044
3	999L021

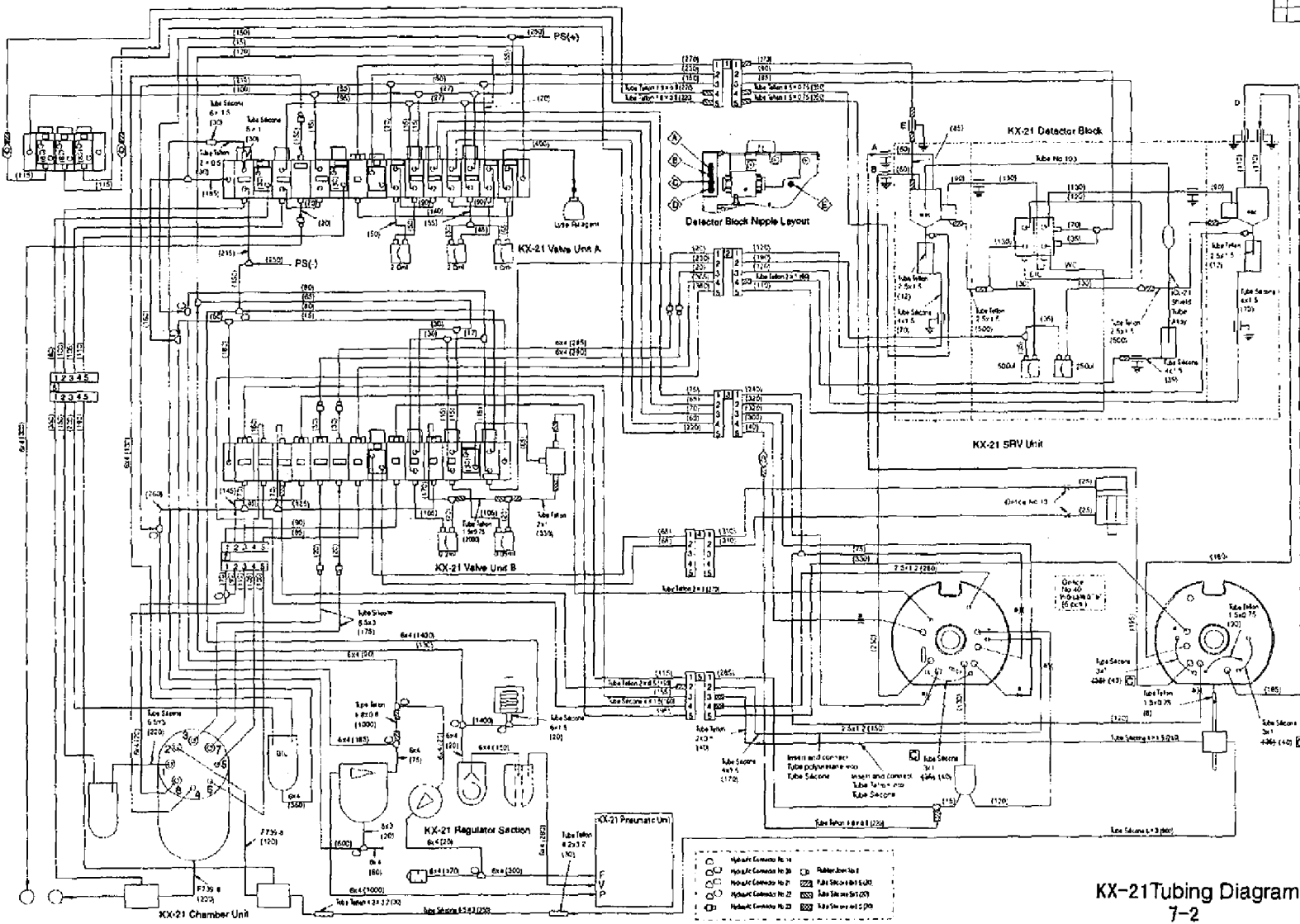

KX-21 Tubing Diagram  
7-2



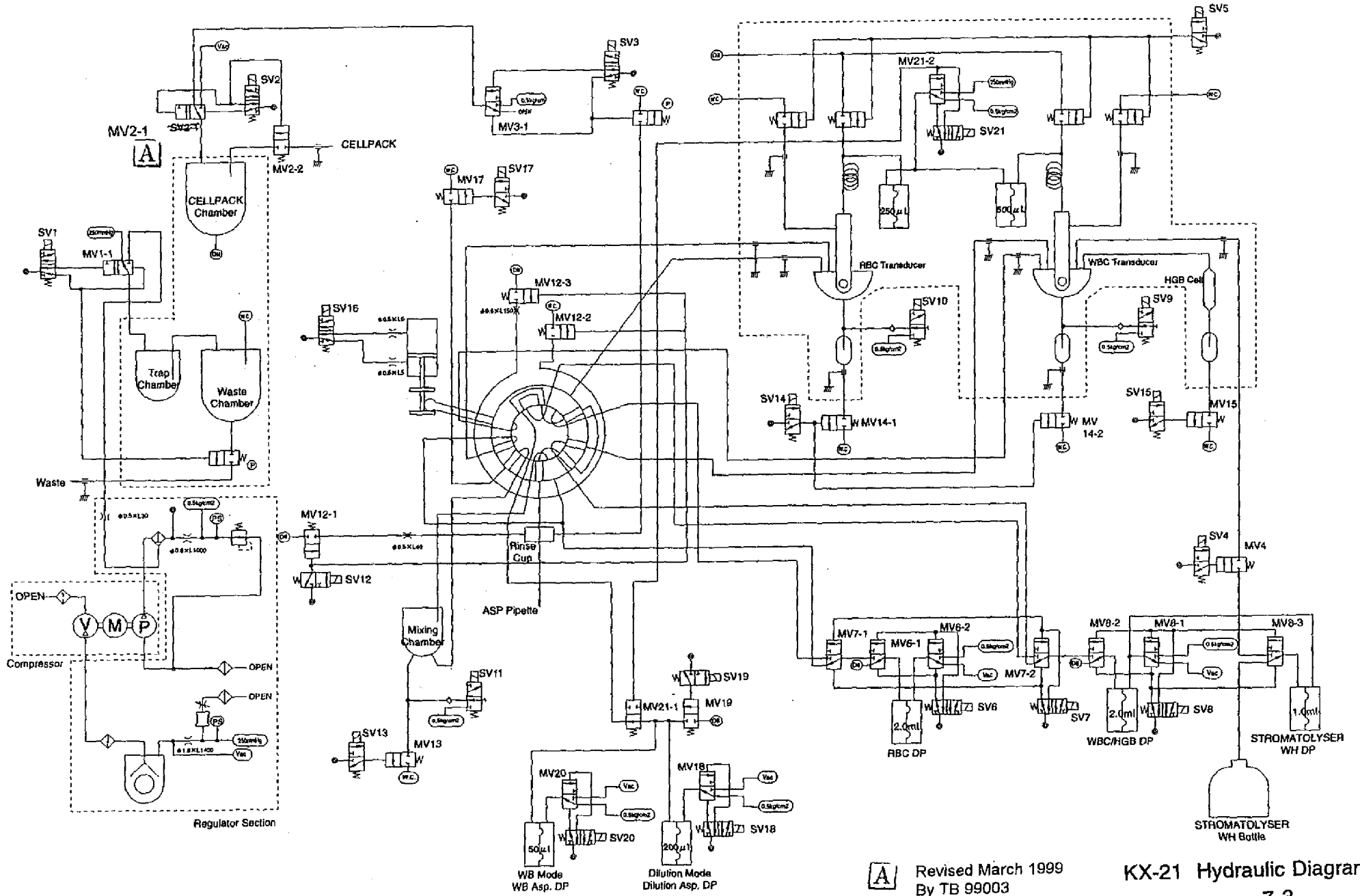

**A** Revised March 1999  
By TB 99003

**KX-21 Hydraulic Diagram**  
7-3

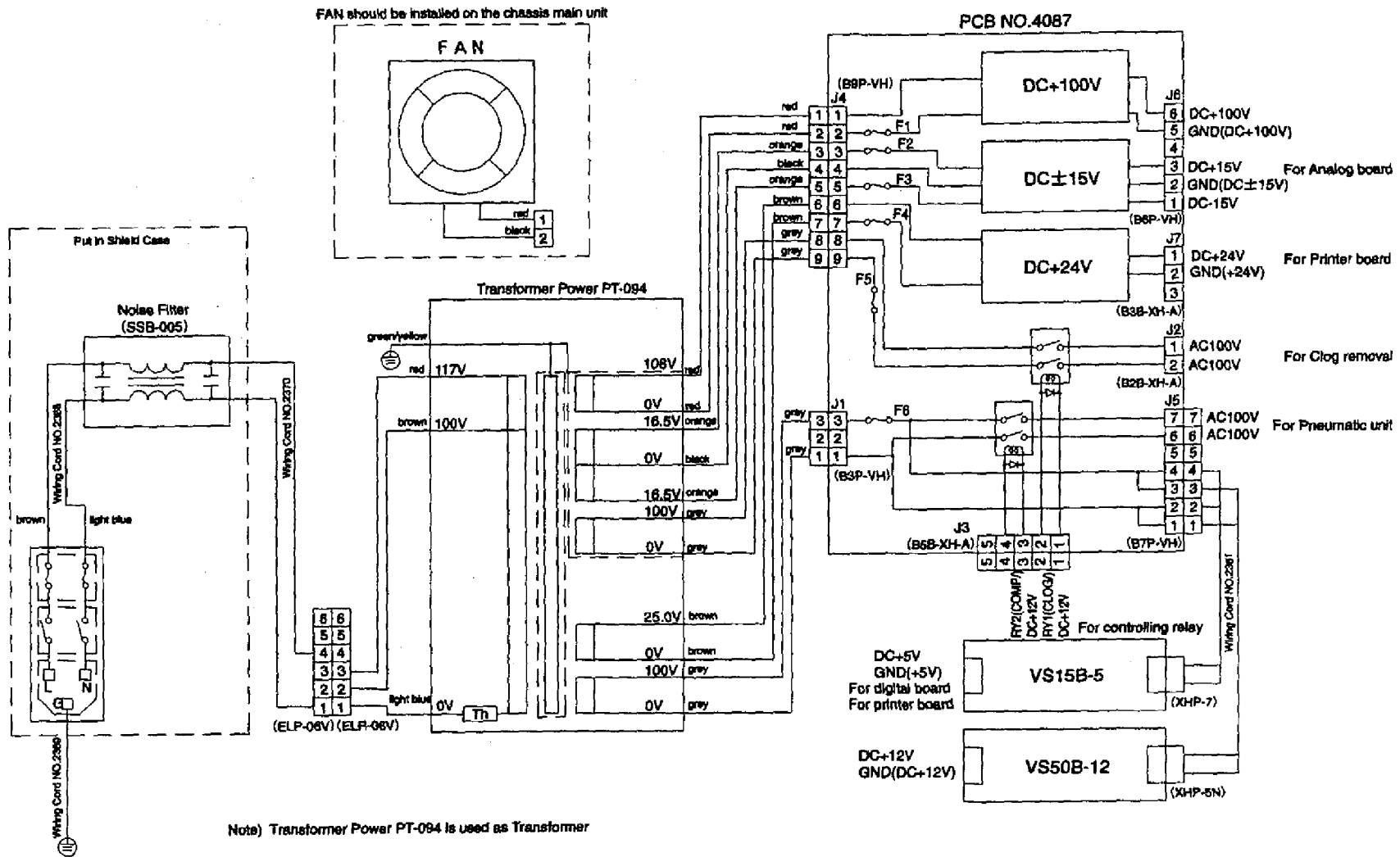

KX-21 Power Supply Unit (100V) Diagram

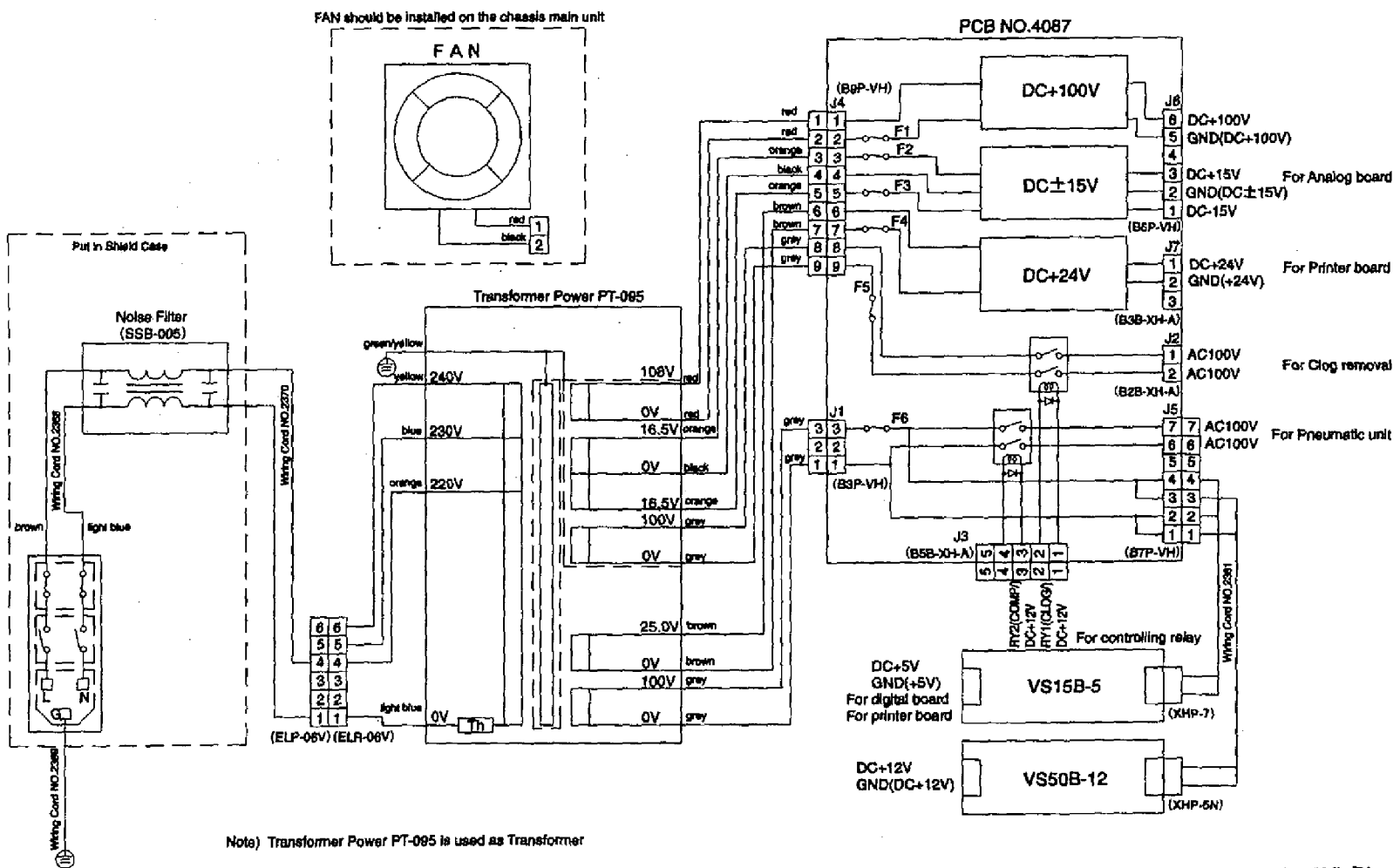

KX-21 Power Supply Unit (200V) Diagram

### Whole Blood Mode Analysis sequence

#### Basic Sequence

Sequence No.	1	2	3	4	5	6	7	8	9	10
Function	WB Asp.	WBC	WBC	WBC	WBC	WBC	WBC	WBC	WBC	WBC
Sample Pipette	WB Asp.	WBC	WBC	WBC	WBC	WBC	WBC	WBC	WBC	WBC
Rinse Cup										
SRV										
Mix Chamber										
RBC										
WBC										
HGB										
CELLPACK Chamber										
Waste Chamber										

### Pre-Diluted Mode Analysis Sequence

#### Basic Sequence

Sequence No.	1	2	3	4	5	6	7	8	9	10
Function	WB Asp.	WBC	WBC	WBC	WBC	WBC	WBC	WBC	WBC	WBC
Sample Pipette	WB Asp.	WBC	WBC	WBC	WBC	WBC	WBC	WBC	WBC	WBC
Rinse Cup										
SRV										
Mix Chamber										
RBC										
WBC										
HGB										
CELLPACK Chamber										
Waste Chamber										

#### SV - Motor Operation

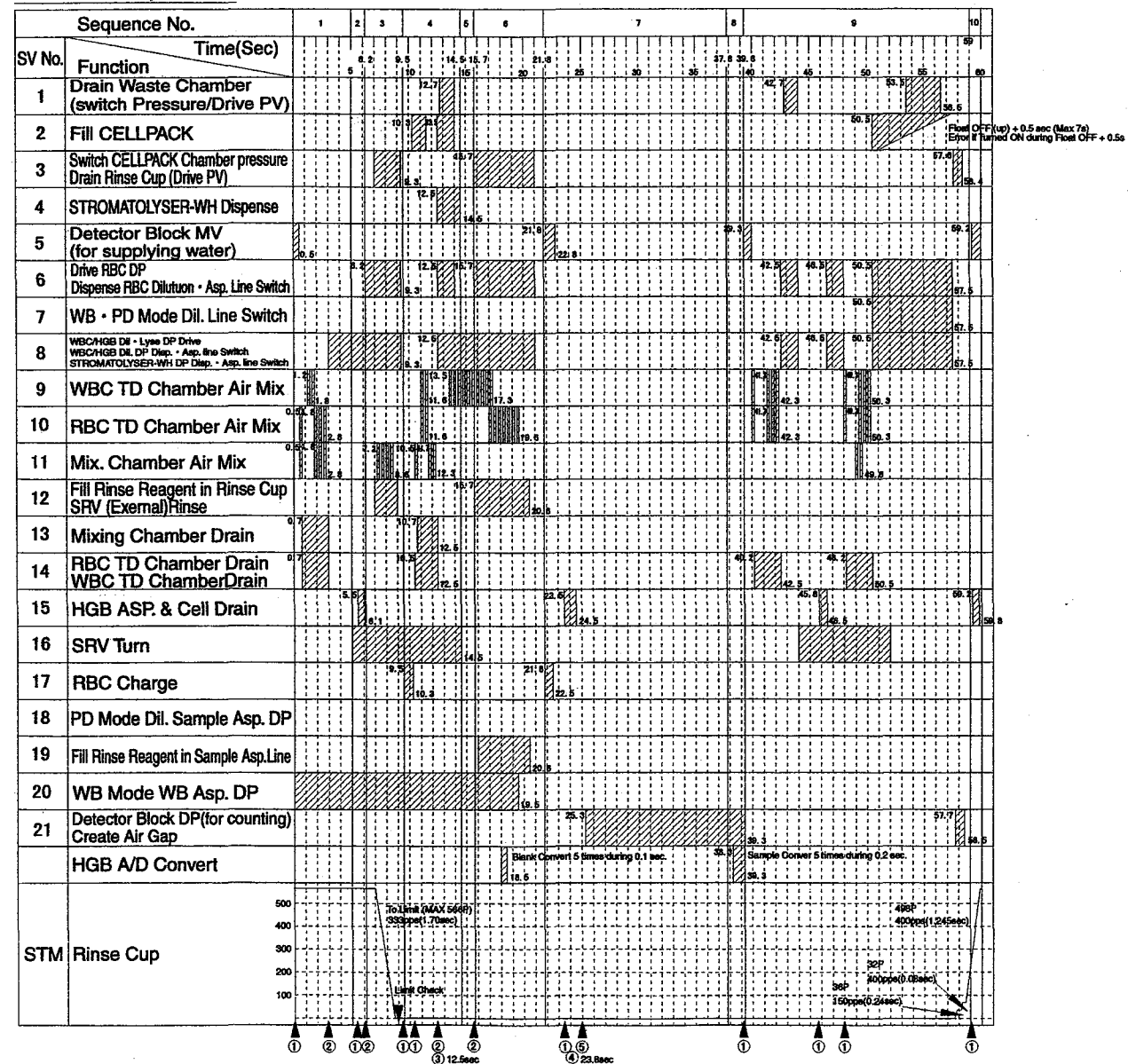

- ① Vacuum Check 250 mmHg
- ② Pressure Check 0.5Kg/cm2
- ③ STROMATOLYSER-WH Volume Check
- ④ Detector Block Temperature Check
- ⑤ Clog Monitor Check

NOTE) 1. Operation of SV9-11 (for Mixing) 0.2s ON 0.2s OFF  
 2. Sequence stop available on Service Mode  
 3. It is recognized as an error after the float switch is turned OFF (lower), approximately 95 operations are performed using STROMATOLYSER-WH.

#### SV - Motor Operation

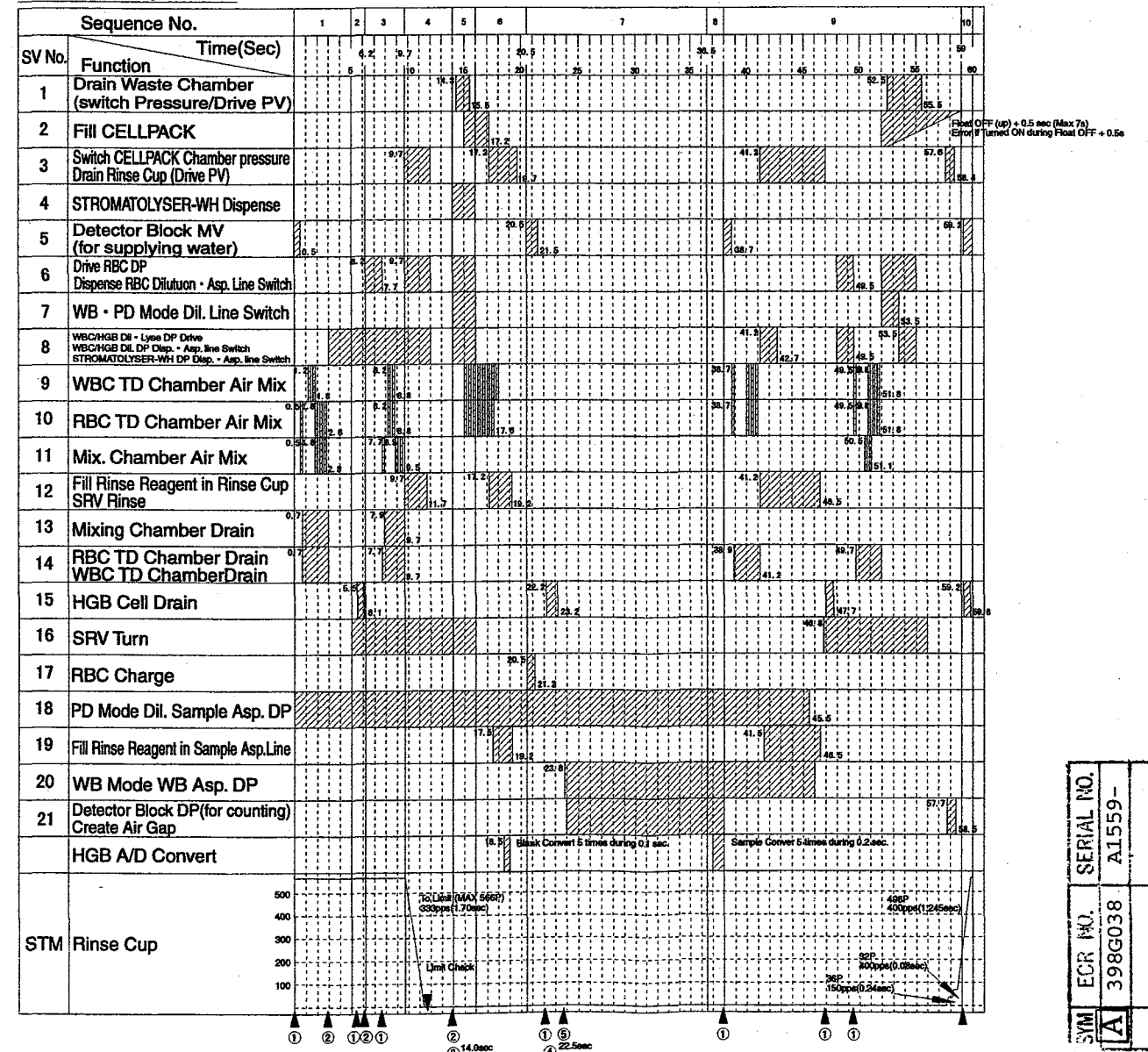

SYM SERIAL NO. A1559-  
 ECR NO. 398G038

### Initial Start-Up Sequence

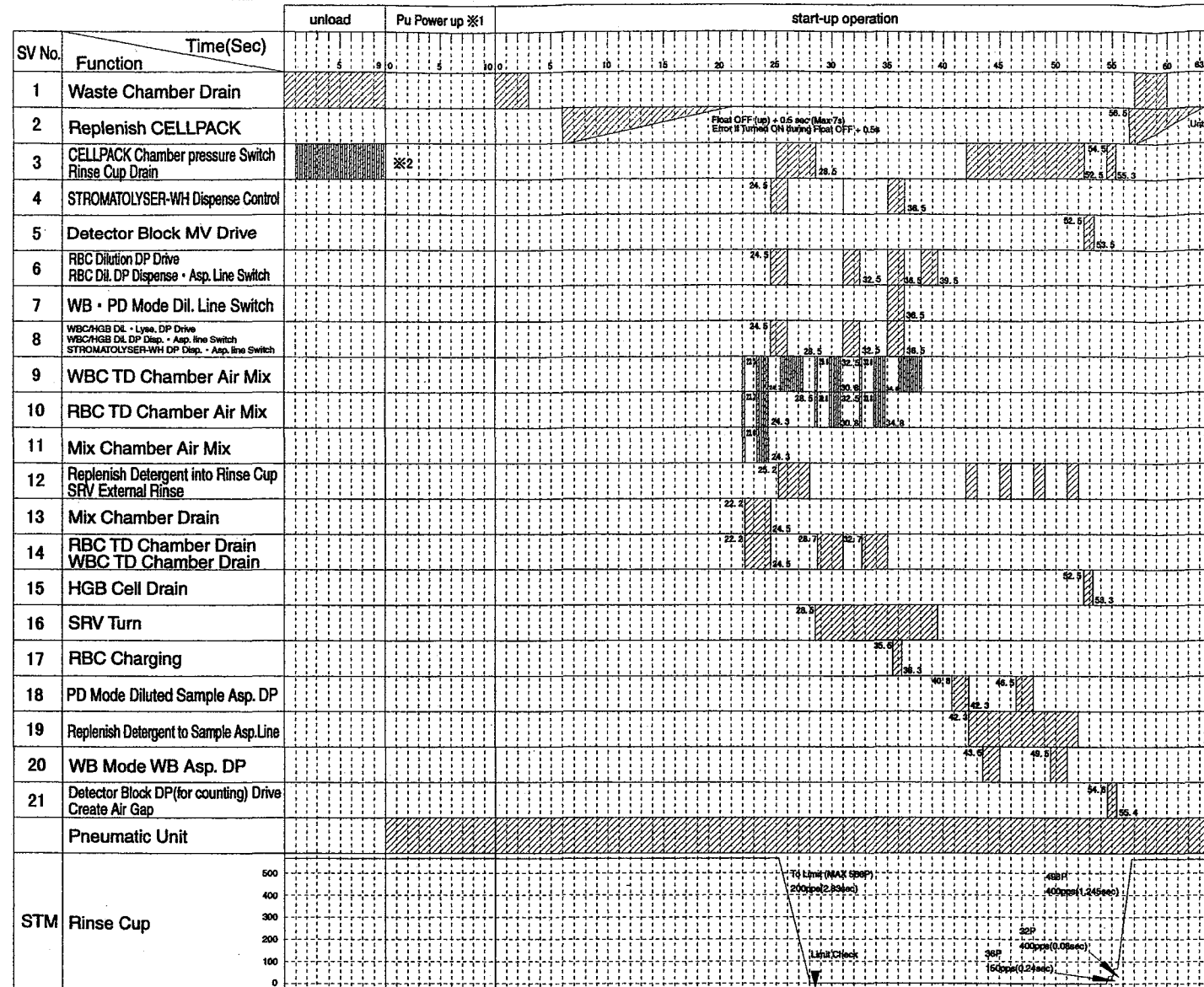

- \*1 Completed when each pressure reaches the lowest pressure.
- \*2 0.2 Sec ON 0.2 sec OFF, repeat until 0.5 kg/cm2 reaches 0.3 kg/cm2 or lower. (Max.20 times)

### Auto Rinse Sequence

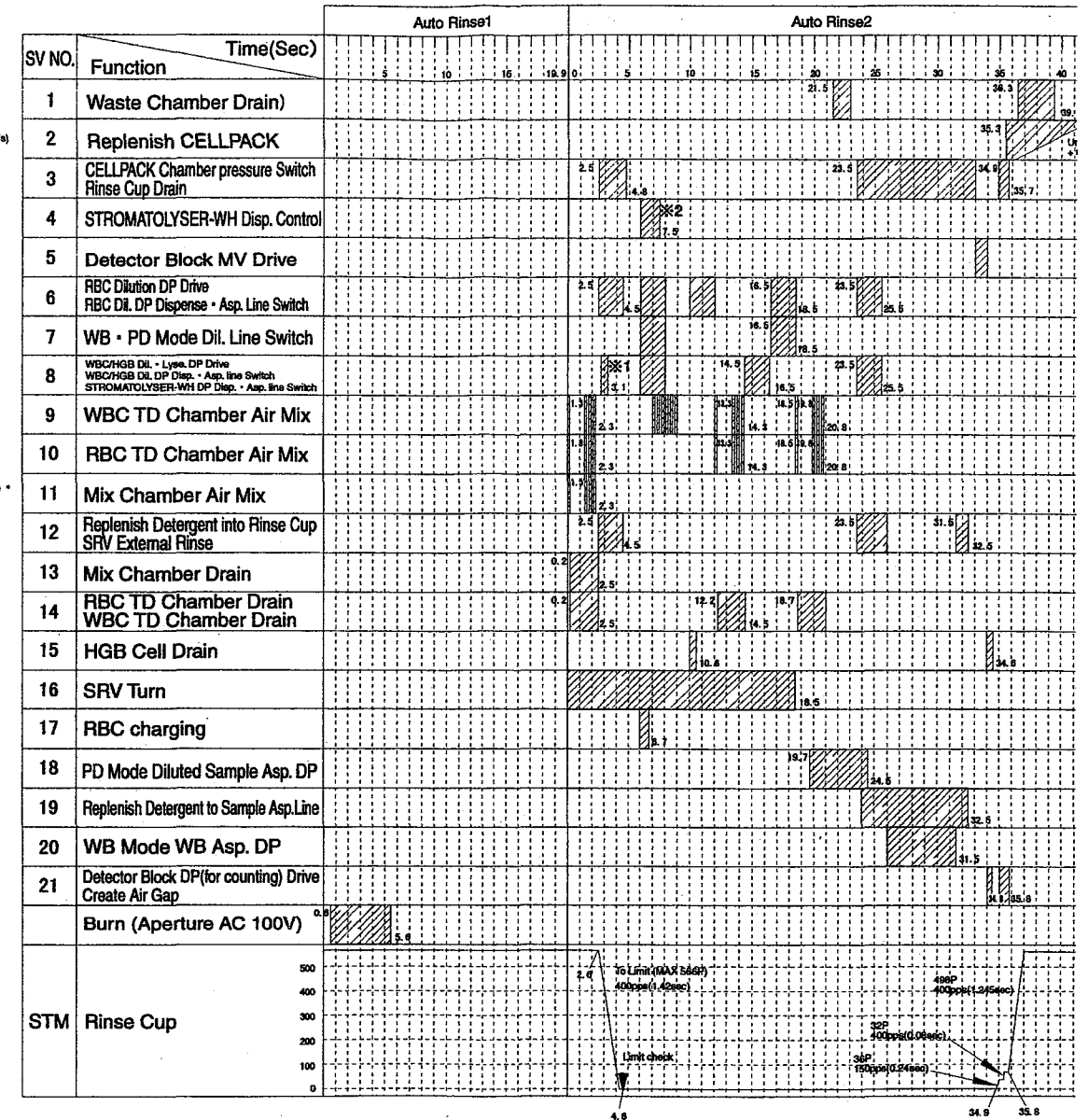

- \*1 When Shut Down, Auto Rinse 2 operates 1 time after Initial Start-Up Sequence.
- \*2 This is performed in every sequence except \*1 sequence.
- Note) 1. Normal Auto Rinse sequence is Auto Rinse1→Auto Rinse2→Auto Rinse2.
- 2. Operation of SV9~11 (for Mixing) is 0.2sec ON 0.2sec OFF.

### Replace · Replenish Lyse-Reagent (STROMATOLYSER-WH) Sequence

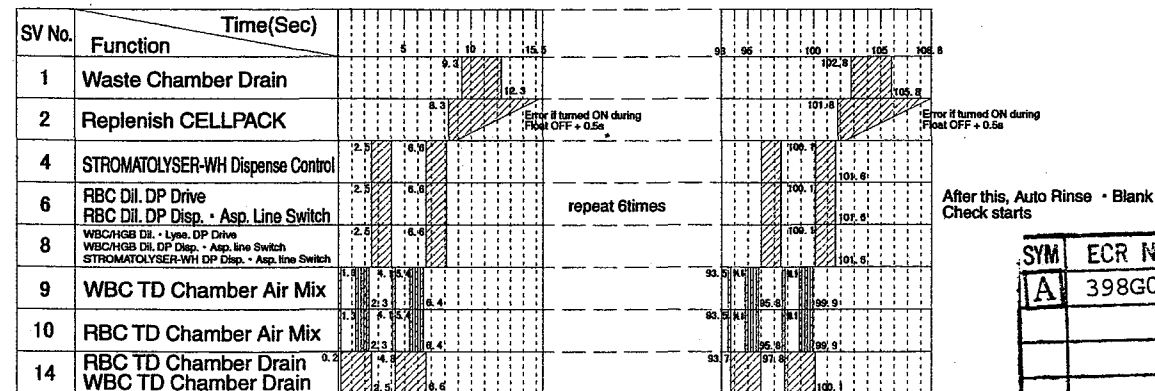

### Replenish Dilution (CELLPACK) Sequence

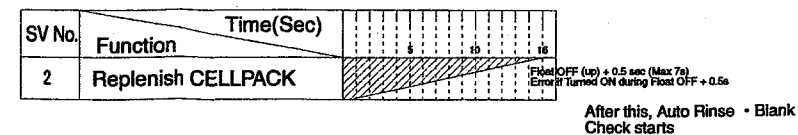

SYM	ECR NO.	SERIAL NO.
A	398G038	A1559-

### Waste Chamber Drain Sequence

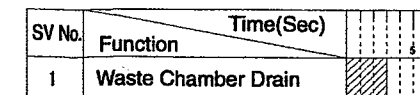

**PU Timer Sequence**

SV NO.	Function	Time (sec)	Prepare for PU OFF				Unload	PU Starting-up ※1
			5	10	15	20		
1	Drain Waste Chamber (Switch Pressure/Drive PV)				13.5			
2	Replenish CELLPACK	8.5		Float OFF (up) (MAX 3 s)				
3	CELLPACK Chamber Pressure Drain Rinse Cup(Drive PV)	8.5		13.5				
4	STROMATOLYSER-WH Dispense Control							
5	Detector Block MV(for supplying water)							
6	Drive RBC DP Dispense RBC Dilution-Switch Asp.Line	8.5		8.5				
7	Switch WB · PD Mode Dil. Line							
8	Drive WBC/HGB Dil. Lyse DP Disp.WBC/HGB Dil.DP-Switch Asp.Line Disp.STROMATOLYSER-WHDP-Switch Asp.Line	1.5						
9	WBC TD Chamber Air Mix							
10	RBC TD Chamber Air Mix							
11	Mixing Chamber Air Mix	0.2						
12	Replenish Detergent into Rinse Cup SRV External Rinse							
13	Drain Mixing Chamber	3.2						
14	Drain RBC TD Chamber Drain WBC TD Chamber							
15	Drain HGB Cell							
16	SRV Turn	1.5						
17	RBC Charging	10.8	7.5	8.3				
18	PD Mode Dil. Sample Asp. DP							
19	Fill Rinse Reagent in Sample Asp.Line							
20	WB Mode WB Asp. DP							
21	Detector Block DP(for counting) Create Air Gap							
	Pneumatic Unit							
STM	Rinse Cup	500 400 300 200 100 0						

PU OFF

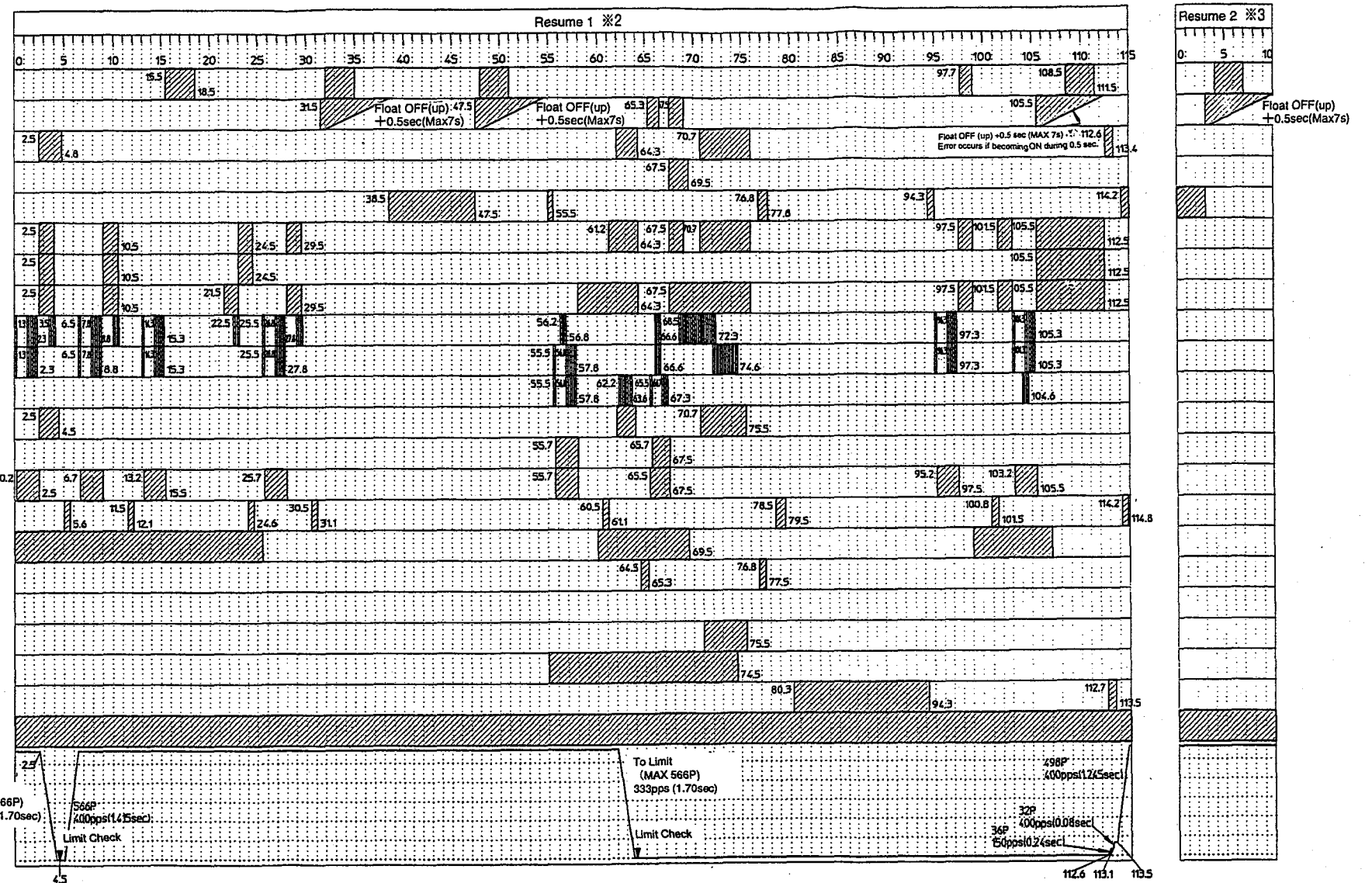

Note) 1.Mode Switch Sequence always operates after PU Starting-Up,Resume 1 and Resume 2.  
2.Operation of SV9~11(for Mixing) is 0.2sec ON 0.2sec OFF.

SYM	ECR NO.	SERIAL NO.
A	398G038	A1559-

KX-21 S/M

KX-21 Timing Chart (3/7)

Revised Sep. 98 **A**

7-8



### Mode Switch Sequence

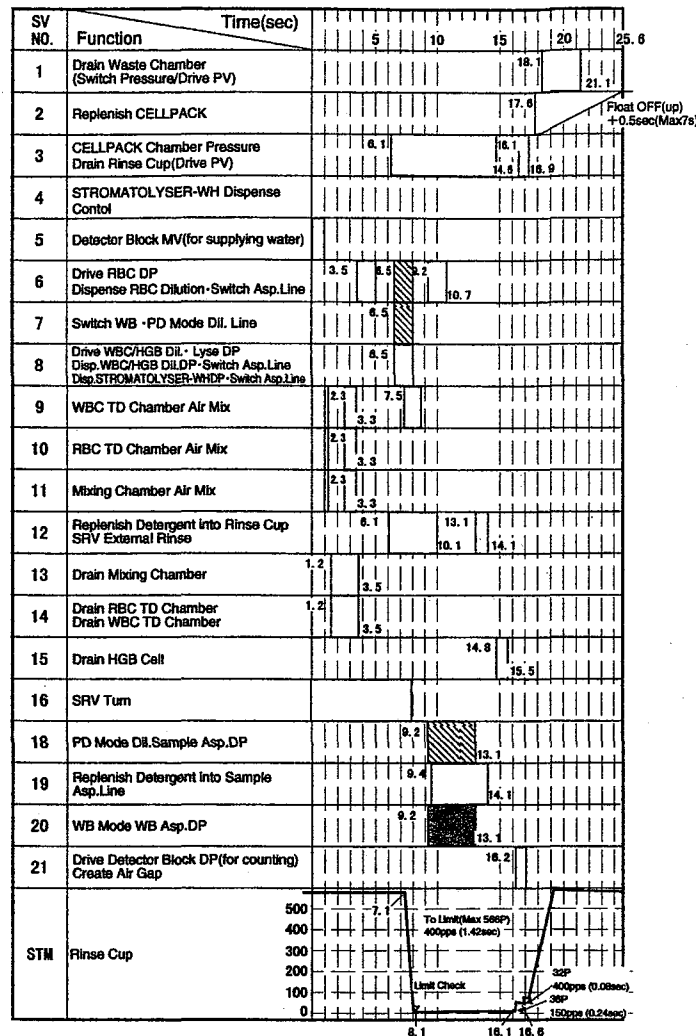

▨ Operate only when WB mode is switched to PD Mode.  
 ▨ Operate only when DP mode is switched to WB Mode.

Note) 1. Operation of SV9~11(for Mixing) is 0.2sec ON 0.2sec OFF.

### Shut Down Sequence

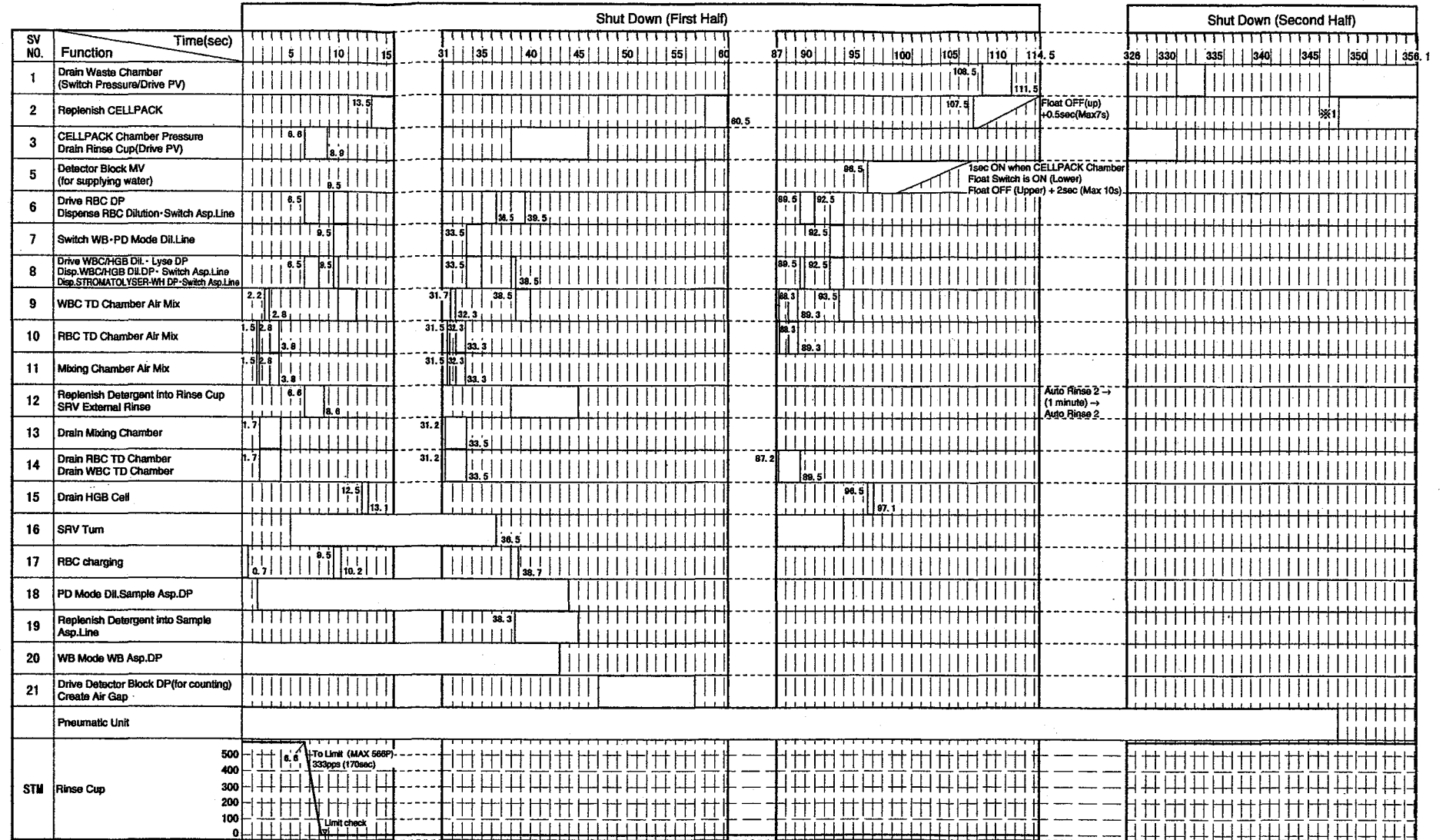

Note) 1. Operation of SV9~11(for Mixing) is 0.2sec ON 0.2sec OFF.

※1 0.2sec ON 0.2sec OFF, repeat until 0.5kg/cm<sup>2</sup> reaches 0.3kg/cm<sup>2</sup> or lower, (Max 20 times)

### Brush Cleaning Sequence

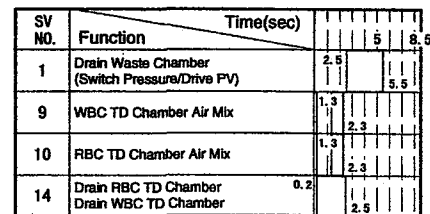

Note) 1. Operation of SV9~10(for Mixing) is 0.2sec ON 0.2sec OFF.

### Diaphragm Pump Test Sequence

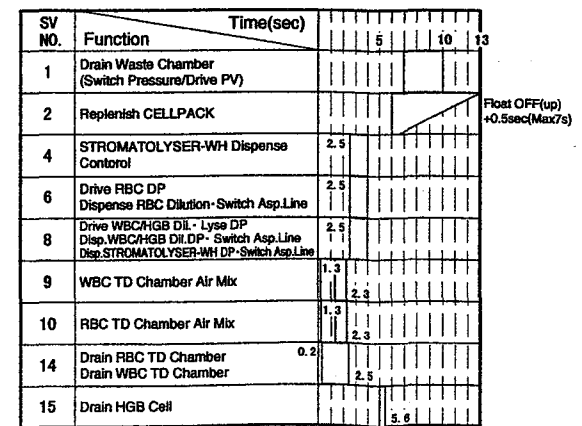

Note) 1. Operation of SV9~10(for Mixing) is 0.2sec ON 0.2sec OFF.

SYM	ECR NO.	SERIAL NO.
A	398G038	A1559-

### TD Cleaning Sequence

SV NO.	Function	Time(sec)	Preparation
1	Drain Waste Chamber (Switch Pressure/Drive PV)		
2	Replenish CELLPACK		
5	Detector Block MV(for supplying water)		
6	Drive RBC DP Dispense RBC Dilution-Switch Asp.Line		
8	Drive WBC/RBC DL-Lysa DP Disp.WBC/RBC DLDP-Switch Asp.Line Disp.STROMTOLYBER-VW DP-Switch Asp.Line		
9	WBC TD Chamber Air Mix	2.3	
10	RBC TD Chamber Air Mix	2.3	
14	Drain RBC TD Chamber Drain WBC TD Chamber	0.2	
15	Drain HGB Cell	2.6	
21	Drive Detector Block DP(for counting) Create Air Gap		
	Sum(Aperture AC 100V)		

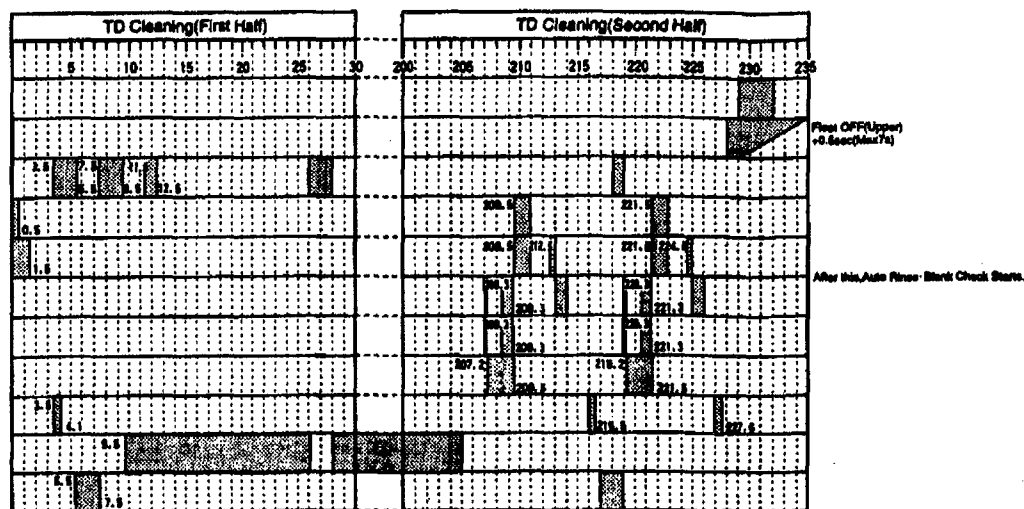

Note) 1. Operation of SV9-10(for Mixing)is 0.2sec ON 0.2sec OFF.

### Recovery Sequence when TD Cleaning Brush Cleaning Sequences are suspended.

SV NO.	Function	Time(sec)	Preparation
1	Drain Waste Chamber (Switch Pressure/Drive PV)	0.5	
2	Replenish CELLPACK	0.5	
5	Detector Block MV(for supplying water)		
6	Drive RBC DP Dispense RBC Dilution-Switch Asp.Line		
8	Drive WBC/RBC DL-Lysa DP Disp.WBC/RBC DLDP-Switch Asp.Line Disp.STROMTOLYBER-VW DP-Switch Asp.Line		
15	Drain HGB Cell	0.5	

### Waste Chamber Rinse Sequence

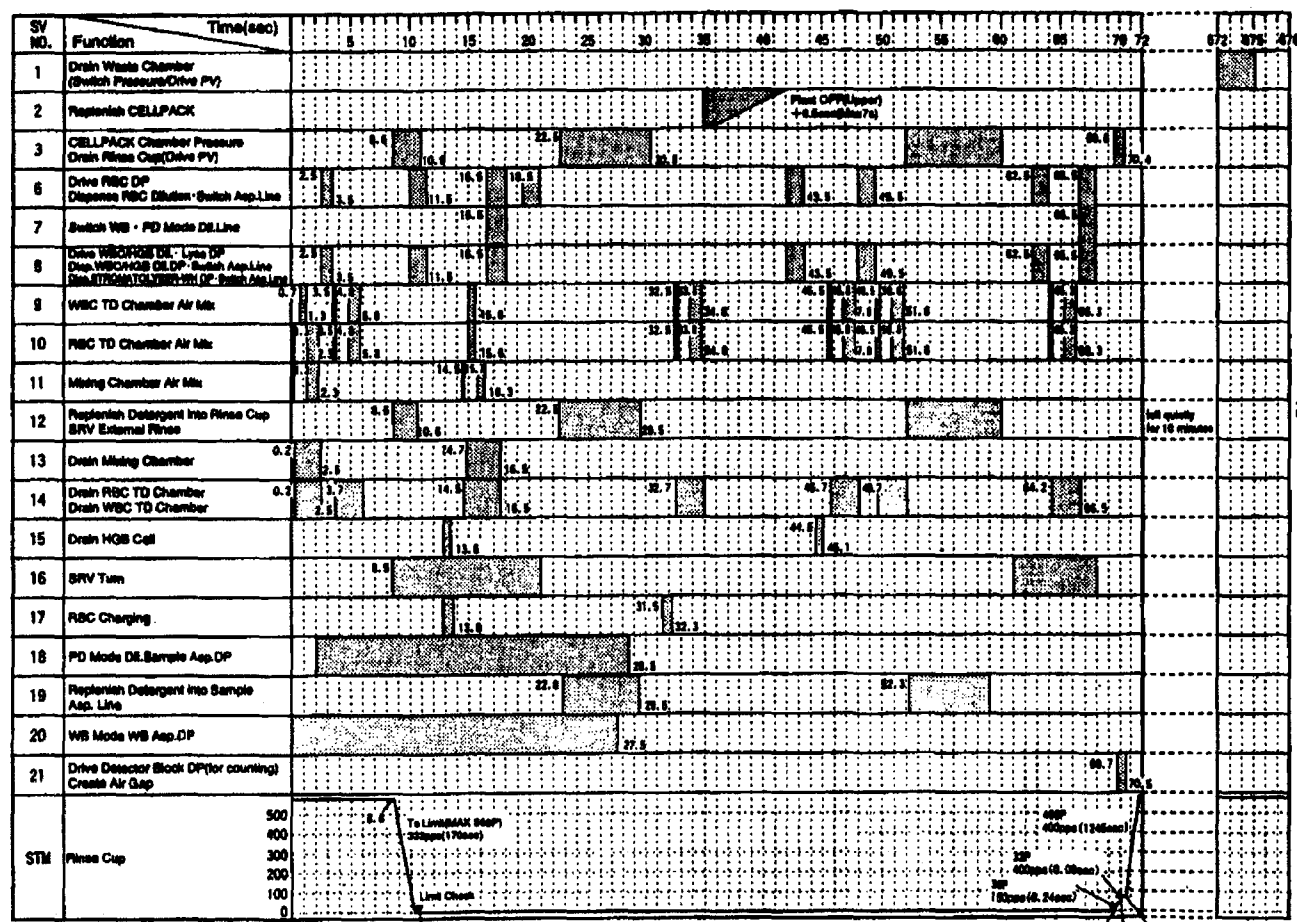

Note) 1. Operation of SV9-11 (for Mixing)is 0.2sec ON 0.2sec OFF.

### Clog Removal Sequence

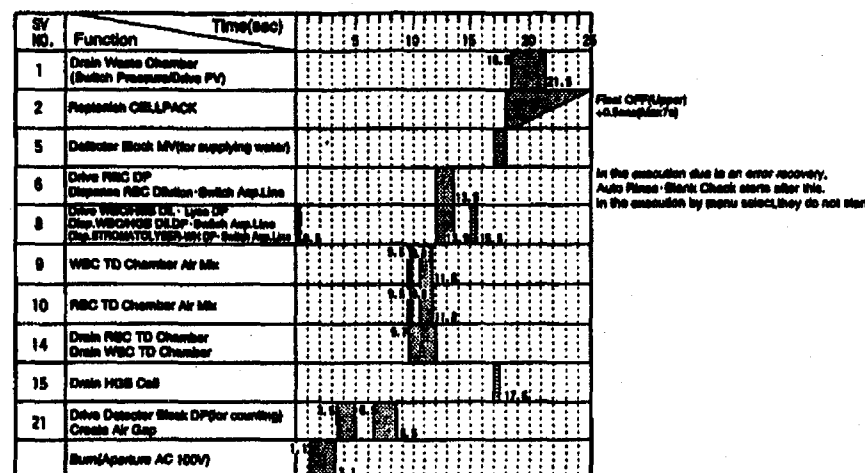

Note) 1. Operation of SV9-10(for Mixing)is 0.2sec ON 0.2sec OFF.



### Sensitivity Adjustment(WBC/RBC)Sequence

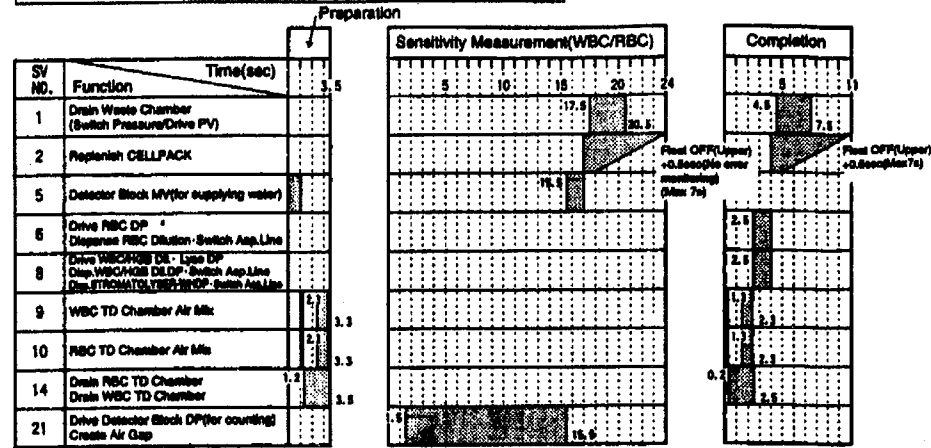

Note 1. Operation of SV9-10(for Mixing)is 0.2sec ON 0.2sec OFF.

### Sensitivity Adjustment(PLT)Sequence

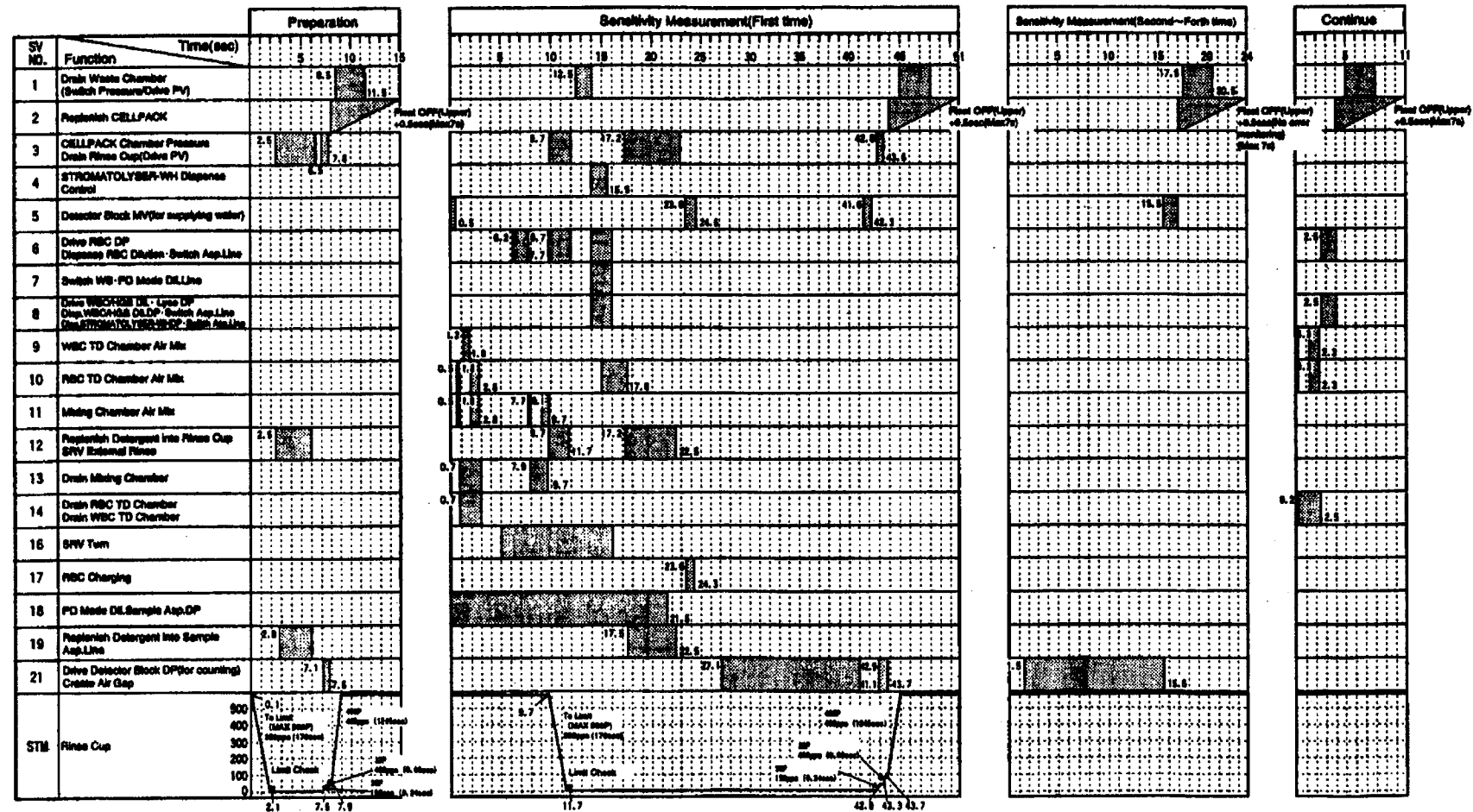

Note 1. Auto-Rinse 2 operates when completed.

Note 2. Operation of SV9-11(for Mixing)is 0.2sec ON 0.2sec OFF.

### Installation Sequence

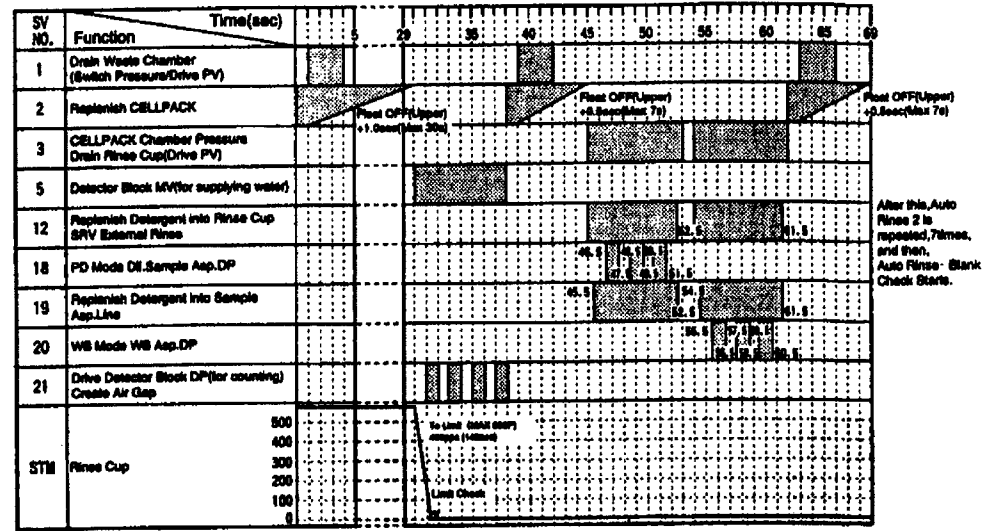

### Depriming Sequence

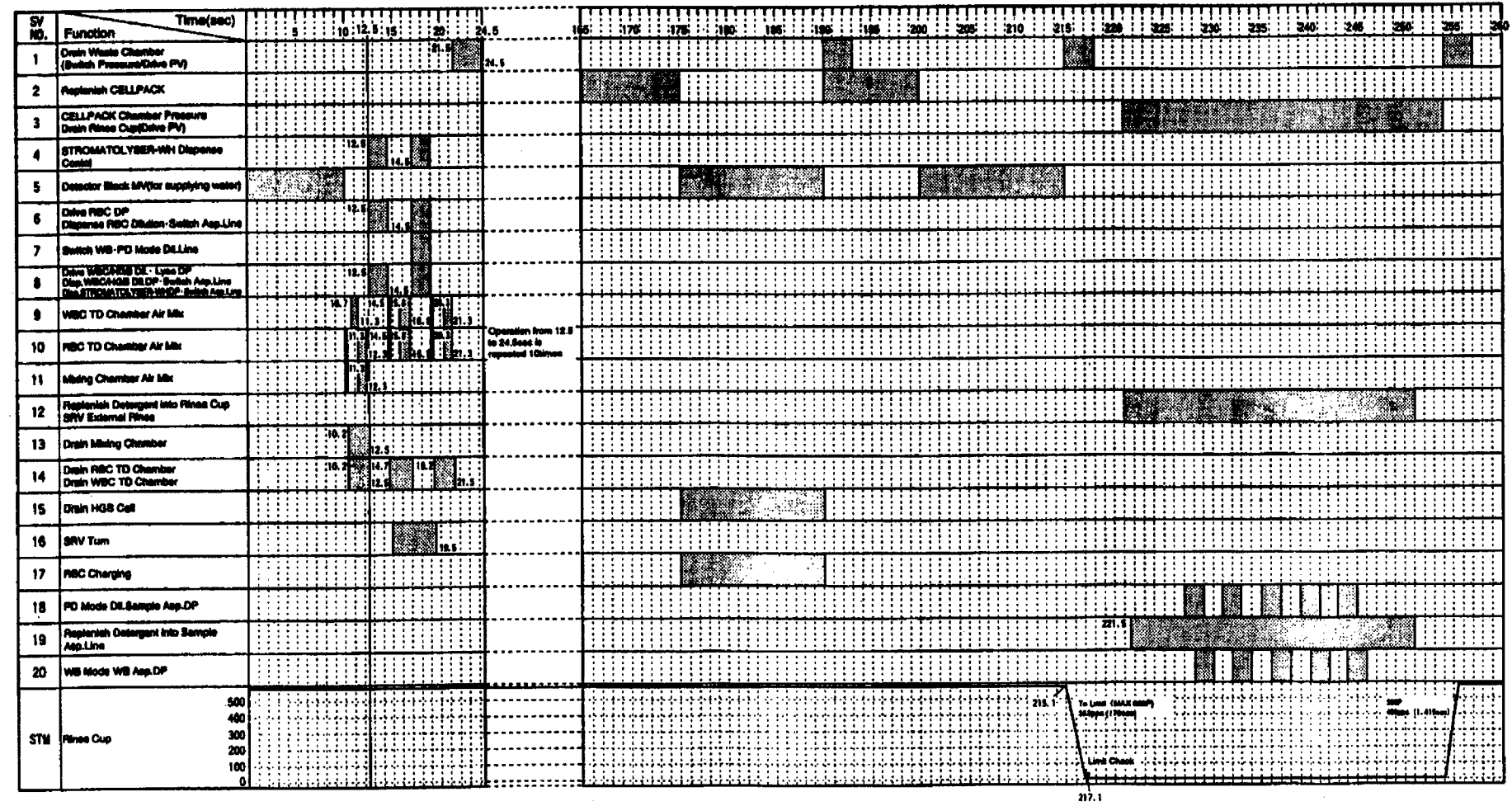

KX-21 Timing Chart (7/7)